

Modular ICS 6.0 Installer Guide

Norstar and Meridian are trademarks of Nortel Networks
© Copyright Nortel Networks 2002

1-800-4 NORTEL
www.nortel.com/norstar

P0992638 03
Printed in Canada

Table of Contents

Regulations 21

- Safety and installation 21
 - For equipment with internal power supplies 21
 - For equipment with external power supplies 22
 - Important safety instructions 22
 - North American regulations 23
 - Federal Communication Commission (FCC) Notice Radio/TV interference 23
 - Devices intended to be connected to the Public Switched Telephone Network 24
 - Signaling method 27
 - Ringer Equivalence Number 27
 - Hearing aid compatibility 28
 - Use of a music source 28
 - Programming emergency numbers 28
 - CE marking 29
-

How to use this document 31

What's new with Norstar 33

- New features for version 6.0 33
 - Functionality changes for version 6.0 35
-

Welcome to ISDN 37

- Comparing ISDN to Analog 38
 - Type of ISDN service 38
 - B channels 39
 - D channels 39
 - ISDN layers 39
 - ISDN bearer capability 40
 - Services and features for ISDN PRI and BRI 41
 - PRI services and features 41
 - BRI services and features 42
 - Feature descriptions 43
 - Network name display 43
 - Message Waiting Indicator (MWI) 44
 - Name and number blocking 44
-

- External call forwarding 44
- MCDN trunk features 45
- Call by Call service selection for PRI 45
- Emergency 911 dialing 46
- MCID (Profile 2) 47
- Network Call Diversion (Profile 2) 47
- DTI card configured as a PRI card 47
- ISDN hardware 48
 - DTI Card configured as PRI 48
 - BRI Card 48
 - BRI-U2 and BRI-U4 card 49
 - BRI-ST card 49
 - U-LT reference point 49
 - U-NT reference points 50
 - S reference point 51
 - T reference points 51
- Clock source for ISDN cards 52
- Other ISDN BRI equipment: NT1 54
- ISDN standards compatibility 54

Working with ISDN 55

- Planning your ISDN network 55
- Ordering ISDN PRI 55
 - Ordering ISDN PRI service in Canada 55
 - Ordering ISDN PRI service in United States 56
- Ordering ISDN BRI 56
 - Ordering service in Canada 56
 - Ordering ISDN service in the U.S. 56
- Supported ISDN protocols 58
- ISDN programming 58
 - Programming ISDN PRI resources 58
 - Programming ISDN BRI resources 60
 - Programming ISDN PRI lines 62
 - Programming ISDN BRI lines 63
 - Programming Direct Inward System Access (DISA) on PRI trunks 64
- Programming ISDN equipment 65
 - Terminal equipment for BRI cards 65
 - Devices on an S or LT loop (BRI cards only) 65
 - ISDN router 67
 - D-packet service (BRI cards only) 68
 - POSTA for ISDN BRI 69

Point-of-sale terminal adapter 69

Trunks and target lines 71

- Trunk operating modes (T1) 72
 - Ground start trunks (T1 only) 72
 - DID trunks 73
 - Analog loop start trunks 75
 - Analog E&M trunks 77
 - BRI trunks 79
 - PRI trunks 79
 - Target lines 80
-

Remote system access 81

- Use system features during a remote call 81
 - Remote access on loop start and E&M trunks 82
 - Remote access on a private network 82
 - Remote access on Direct Inward Dial (DID) trunks 83
 - Remote access on PRI trunks 83
-

Controlling system access 85

- Class of Service 85
 - Restriction filters 86
 - Direct inward system access (DISA) 89
-

Networking with Norstar 91

- Tie-line networking 92
 - Norstar behind a PBX 93
 - Dialing plans 94
 - Dialing plan using public lines 96
 - Destination code numbering in a network 96
 - Dialing plan using E&M lines 97
 - Dialing plans with shared line pools 102
 - Call-by-Call Services Example 104
 - Norstar Configuration 106
 - PRI dialing plan example for two-way DID 108
 - Static DID and two-way DID 109
 - Private networking using PRI SL-1 110
 - SL-1 networking features 110
 - Features specific to Advanced Private Network 111
 - Private Network Tandem calling 112
-

- Calls originating from the public network 113
- Calls originating in the private network 116
- Routing for tandem networks 119
- Advanced Private Networking 121
 - Networking using routing codes 121
- MCDN Private Networking 126
 - Using a UDP dialing plan 127
 - Using a CDP dialing plan 130
- MCDN trunk call features 133
 - Network Call Redirection Information 134
 - ISDN Call Connection Limitation 136
 - Trunk Route Optimization 138
 - Trunk Anti-tromboning 140
- MCDN voice mail/auto attendant call features 141
 - Camp-on 142
 - Break-in 143
- Central voice mail and Auto Attendant with Norstar 146
- Configuring centralized voice mail 146
 - Local system 147
 - Remote system 148
- Using centralized voice mail 149
- Configuring Centralized Auto Attendant (CAA) 150
 - Assigning PNLs 150
 - Assigning PNLs for adjacent nodes 151
 - Local system 151
 - Remote system 152
- Voice mail configuration 154
- Customer Use 155
 - Public network 155
 - Private network 159
 - Call one or more Norstar telephones 159
 - Use tie lines to other nodes in the private network 160
 - Select lines to the public network 161
 - Select E&M trunks to the private network 162
 - Norstar Line Redirection feature 163
- ETSI MCDN and network features 165
 - Network Call Diversion 165
 - Allowing NCD 166
 - Feature description 166
 - Programming and restrictions 167
 - Selective Line Redirection 168
 - Programming Extensions 169

Enhanced Caller ID 169
Malicious caller identification (MCID) 170
Programming MCID capability 170

Data Solutions 173

Examples of ISDN Scenarios 173
ISDN applications 173
Video conferencing and video telephony 173
Desktop conferencing 173
File transfer 174
Telecommuting 174
Group 4 fax 174
Remote LAN access 174
Leased line backup 174
LAN to LAN bridging 175
Internet and database access 175

Planning the installation 177

Planning checklist 178
 Hardware 178
 Initial configuration 178
 System configuration 179
Required equipment 179
Expansion equipment 180
Optional equipment 181
Equipment for installing the ICS and modules 182
Location requirements 182
Electrical requirements 184
Configuring Trunk Cartridges 185
Configuring Station Modules 186
Internal wiring requirements 186
 Norstar loop 186
 ISDN S reference point (S Loop) 187
System overview 188
Upgrading your Norstar system 189
Supported upgrades in MICS 6.0 192
Upgrading from MICS 6.0 to MICS-XC 6.0 196
Trunk and Station Modules 199
 Global Analog Trunk Cartridge/CLI Cartridge 200
 Off-core DTI card 201
Replacing a Modular 8x24 KSU 201
Trunk module line numbering 205

Installation 209

- Installation checklist 210
- Testing the ISDN BRI network connection 211
- Installing the cartridges 213
- Mounting the modules 215
 - Installation tips 217
- Installing the ROM Software Cartridge 219
- Inserting a cartridge 221
 - Terminating resistors on BRI-ST Cards 222
 - Shorting straps on a BRI-ST card 223
- Connecting expansion modules 224
 - Order of connection 224
 - Analog Station Module 224
- Installing fiber cables 230
- Fiber cable management system 231
 - Using the fiber cable management system 232
 - Using the fiber spool 234
 - Making fiber connections 235
 - Routing fiber cables 236
- Connecting the wiring 237
 - Connecting the wiring to the distribution panel 237
- Wiring charts 241
 - Port numbering on the wiring charts 241
 - Integrated Communications System (ICS) 241
 - BRI Wiring charts 248
 - Wiring the BRI network interface 252
 - DTI wiring 254
 - E&M/DISA Trunk Cartridge wiring chart 257
 - DID supervisory signaling 261
 - Emergency transfer conditions 261
- Emergency telephone 265
- Moving telephones 267
- Installing ISDN BRI terminal equipment 268
 - S or T wiring for terminal equipment 268
 - S or T extension wiring configurations 268
 - Additional power 269
 - U-LT wiring for terminal equipment 270

-
- Installing optional equipment 271
 - Auxiliary ringer (customer supplied) 271
 - Auxiliary ringer programming 271
 - External music source (customer supplied) 272
 - External music source programming 272
 - External paging system (customer supplied) 273
 - Powering up the system 274
 - Check the power 275
-

Programming 277

- Programming overview 278
 - Profile, Dialpad and Startup programming 279
 - Installer or System Coordinator Plus programming 280
 - System Coordinator programming 281
 - Admin/Basic programming 281
- Programming tools 282
 - The programming overlay 283
 - Using the telephone buttons for programming 284
 - Special characters on the display 285
 - The display buttons 285
 - The Norstar Programming Record 287
 - Exiting 287
 - Viewing your programming updates 287
 - Entering numbers 288
 - Viewing long telephone numbers 288
 - Setting up User Preferences 289
- Copying telephone programming 290
 - System ID 293
 - Reviewing programmed settings 293
 - Viewing the programming for a telephone 294
 - Viewing the programming for a line 294
- Programming sequence 295
- Profiles and Dialpads 296
 - Profile programming 296
 - Profile parameters 296
 - Changing the profile 299
 - Dialpad programming 300
- Startup programming 301
 - Performing Startup 301
 - Changing the default template 302

- Changing the starting DN 302
- Programming 304
 - Entering programming for installers 305
 - Entering programming for system coordinators 306
 - Entering programming using other passwords 307
- Terminals&Sets 308
 - Line access 308
 - Line assignment 309
 - Appearances 310
 - Line pool access 312
 - Prime line 313
 - Intercom keys 314
 - Answer DNs 314
 - OLI # 315
 - Capabilities 317
 - ATA settings 319
 - ATA ans timer 319
 - ATA use 320
 - ATA dvc 320
 - MsgIndicate 320
 - Name 320
 - User prefernces 321
 - Restrictions 322
 - Filters 322
 - Default filters 324
 - Set restrns 327
 - Filters 327
 - Set lock 328
 - Allow last no 328
 - Allow saved no 328
 - Allow link 328
 - Line/set restrns 329
 - Telco features 330
 - Feature assignment (CLID alignment) 330
 - Caller ID set 330
 - Extl VMsg set 331
 - 1stDisplay 331
 - Called ID 332
 - Log space 332
- Lines 333
 - Trunk/Line data 333

- Copying Trunk and Line data 335
- Trunk type 335
- Line type 336
- Line connected to a DTI 337
- Dial mode 338
- Rec'd # 339
- Prime set 340
- Auto privacy 340
- Trunk mode 341
- Ans mode 341
- Ans with DISA 342
- Link at CO (loop trunks only) 343
- Aux. ringer 343
- Full AutoHold 344
- LossPkg 344
- Signal 345
- ANI Number 346
- DNIS Number 346
- Gain 347
- Programming distinctive ring patterns 348
- Name 349
- Restrictions 349
 - Restrnr filters 350
 - Line restrns 350
 - Remote restrns 351
- Telco features 352
 - VMsg center 1 352
- Services 353
 - Common settings 354
 - Control sets 354
 - Schedule names 355
 - Schedule times 355
 - Ringng service 357
 - Ringng groups 357
 - Sched:Night 358
 - Service 358
 - Trunk answer 358
 - ExtraDial telephone 359
 - Line settings 359
 - Restrnr service 360
 - Routing service 361
- Routes and destination codes 363

- Routes 363
 - DialOut 364
 - Use Pool 364
 - Routing table 365
 - Programming the PRI routing table 366
- Dest codes 367
 - Wild card character 368
 - Normal rte 370
 - Digit Absorption 370
- Setting up a route for local calling 371
- Setting up a route for long distance calling 373
- Adding a long distance carrier access code 375
- Programming for least cost routing 377
 - Sched:Night 378
- Using dialing restrictions with routing 380
- Sys speed dial 381
- Passwords 382
 - COS pswds 382
 - Pswd 383
 - User flt 383
 - Line flt 383
 - Remote pkg 384
 - Call log pswd s384
- Progrming pswds 385
 - Installer 385
 - SysCoord+ 386
 - SysCoord 386
 - Basic 386
- Registration password (MICS-XC only) 386
- Hospitality password 387
 - Desk pswd 387
 - Cond pswd 387
- Time&Date 388
- System prgrming 389
 - Hunt groups 389
 - Adding or removing members from a group 390
 - Moving members of a group 391
 - Assigning or unassigning lines to a group 392
 - Assigning a distinctive ring pattern to a Hunt Group 392
 - Setting the distribution mode 393
 - Setting the hunt delay 394

- Programming busy line setting 395
- Programming the queue timeout 395
- Programming the overflow set 396
- Setting the function name 396
- Change DNs 397
- Featr settings 397
 - Backgrnd music 397
 - On hold 398
 - Receiver volume 398
 - Camp timeout 398
 - Park timeout 399
 - Park mode 399
 - Trnsfr callbk 399
 - DRT to prime 400
 - DRT delay 400
 - Held reminder 400
 - Remind delay 401
 - Directd pickup 401
 - Page tone 401
 - Page Timeout 402
 - Daylight time 402
 - AutoTime&Date 402
 - Setting SWCA controls 403
 - Call log space 405
- Host delay 406
- Link time 406
 - AlarmSet 406
 - Set relocation 407
 - Msg reply enh 407
 - Answer key 408
 - Clid match 409
- Direct-dial 410
 - D-Dial1 410
 - Intrnl/Extrnl# 410
 - Line selection 410
- CAP assignment 411
- Dialing Plan 412
 - DN lengths (enbloc dialing) 412
 - Private networks 413
 - Public networks 415
 - Dial Timeout 416
- Access codes 416

- Line pool codes 417
- Park prefix 418
- External code 419
- Direct-dial # 419
- Auto DN 420
- DISA DN 421
- PrivAccCode 421
- Carrier Codes 422
- Remote access 423
 - Rem access pkgs 423
 - Rem line access 423
- Changing Companion DN type 425
- Rec'd # length 426
- DN length 427
- Nat'l length (profile 2, only) 428
- Make/Break (profile 2, only) 428
 - BusName 429
 - Receiving and Sending Calling Party Name 429
 - Receiving and Sending Connected Name 430
 - Network Name Display interactions 430
 - Programming Network Name Display 431
 - Outgoing Name and Number Blocking 432
- Call by Call service selection for PRI 433
 - Line Pools 436
 - Programming Call by Call service selection 436
 - PRI Call by Call Limits 437
 - Programming Call by Call Limits 437
 - Release Reasons 438
 - Mk/BR: 40/60 (profile 2 only) 438
 - Programming Hospitality Services 439
 - Room/desk information 439
 - Call restrns 440
 - Setting Service times 440
 - Configuring alarms and expired alarms settings 441
- Network Services 442
 - ETSI: Network diversion and MCID (profile 2 only) 442
 - Network Call Diversion 443
 - Malicious call identification (MCID) 445
 - MCDN services (profiles 1, 2, 4) 445
- Telco features 447
 - VMsg ctr tel#s 447
 - Outgoing Name and Number Blocking 448

- Programming the analog vertical service code (VSC) 449
- Programming the BRI VSC 449
- Setting up the modules for ONN blocking 450
- Software keys 452
 - ISDN-PRI 452
 - MCDN 452
 - Companion (MICS-XC only) 452
 - System Identification Number 453
 - Call the Nortel Customer Response Center 453
 - Entering the software keys 454
- Hardware 455
 - Show module 455
 - Cards on KSU 455
 - Provisioning the DTI card for PRI 456
 - Selecting a protocol 456
 - BchanSeq 458
 - Call-by-call routing 458
 - Discon timer 460
 - Answer timer 460
 - CO fail 460
 - I/F levels 461
 - Framing 462
 - Internal CSU 462
 - CSU line bld 463
 - Line coding 464
 - ClockSrc 464
 - Max transits 465
 - Modules 465
 - StnMod 466
 - ASM 466
 - TrunkMod 467
 - BRI card 471
 - Loop 471
 - Type 471
 - Lines 471
 - No SPIDs assignd 472
 - # of B-channels 472
 - Network DNs 473
 - Call type 473
 - D-packet service 474
 - Lp 474
 - TEIs 474

- No TEIs on loop 475
- Sampling 475
- DNs on Loop 475
- Assign DN's 476
 - Loop DN 476
- Clock Src 476
 - Primary reference 477
 - Secondary reference (Secndry) 477
 - Timing master (TimeMst) 477
- Setting the clock source for DTIs and PRI 481
 - T1 or ISDN-PRI configurations 482
- DataMod 483
 - Type 483

Maintenance 485

- Beginning a Maintenance session 486
- System version 487
 - Checking the version of the system 487
- Port/DN status 488
 - Identifying a connected device 489
 - Displays 490
 - Checking the device version number 491
 - Checking the state of the device 491
 - Disabling a device 492
 - Displays 493
 - Enabling the device 493
 - Returning to the beginning 494
- Module status 495
 - Looking at the module inventory 495
 - Checking the number of Cartridges 496
 - Checking the state of a module 496
 - Checking the state of a cartridge 497
 - Disabling a module or its cartridges 498
 - Enabling a module or its cartridge 498
 - Returning to the beginning 498
- System test log 499
 - Checking the items in the log 499
 - Checking the current alarm 500
 - Checking when each item occurred 500
 - Checking consecutive repetitions of an event or alarm 500
 - Erasing the log 501

- System administration log 502
 - Checking the items in the log 502
 - Checking the current alarm 503
 - Checking when each item in the log occurred 503
 - Erasing the log 503
- Network evt log 504
 - Checking the items in the log 504
 - Checking the current alarm 504
 - Erasing the log 505
 - Checking when each item in the log occurred 505
- Alarm codes 506
 - If you see an alarm code 507
 - Alarm troubleshooting 510
- Event messages 514
 - Dealing with event messages 514
 - Significant event messages 515
 - Event message 799 518
 - Displays 519
- Provisioning BRI and PRI lines 522
 - BRI and T1 lines 522
 - Cd1-ICS 522
 - L001 523
 - Provisioning a T1 line 523
 - Provisioning a PRI line 523
 - Deprovisioning a line 524
 - Disabling a PRI Channel 524
- Tests 525
 - Loopback tests for T1 or ISDN-PRI lines 525
 - Tests initiated from Norstar 529
 - Tests initiated by the central office 529
 - Starting a loopback tests 530
 - Operating a Continuity loopback test 531
 - Loopback test for BRI lines 531
 - Operating a payload loopback test 532
- CSU stats 533
 - Statistics 533
 - Checking the performance statistics 534
 - Checking the CSU alarms 536
 - Checking active alarms 536
 - Checking carrier failure alarms 536
 - Checking bipolar violations 537

- Checking short term alarms 537
 - Checking defects 537
 - Resetting all statistics 538
 - Diagnostic tools 539
 - Link Status 540
 - Fractional PRI 540
-

Usage Metrics 541

- Hunt groups 541
 - Call-by-Call 542
 - Clearing the metrics 543
-

Troubleshooting 545

- Getting ready 546
 - Types of problems 547
 - Misunderstanding a feature 547
 - Programming errors 547
 - Wiring connections 547
 - Equipment defects 547
 - General troubleshooting procedure 548
 - Problems with telephones 549
 - Set has faulty buttons, display, handset or other hardware problems 549
 - Unreadable set display 549
 - Telephone dead 550
 - Running a Maintenance session to test a dead telephone 551
 - Replacing a telephone 551
 - Emergency telephone dead 552
 - Problems with lines 553
 - Calls cannot be made (but can be received) 553
 - Dial tone absent on external line 554
 - Hung lines at a telephone 555
 - Auto-answer line rings at a telephone 556
 - Prime telephone gets misdialed calls 558
 - Selected lines reads Not in service or Not available 559
 - Selected line pool displays: No free lines 561
 - Problems with optional equipment 562
 - Analog Terminal Adapter 562
 - Running a Maintenance session to test an ATA 562
-

- Auxiliary ringer 563
- External paging 564
- Music on Hold/Background Music trouble 564
- Problems with trunk cartridges service 566
 - Digital Trunk Interface trouble 567
 - Monitoring the T1 or PRI signal 569
- Problems with BRI service 570
 - The BRI card is connected to the ISDN network (U loop) but the LED for one of more loops is not lit 570
 - Solution 570
 - Out of service displays when a BRI is selected (LED for loop is lit) 571
 - All the LEDs on a BRI Card are flashing 571
 - Caller hears one ring and then a fast busy signal when placing a call on a BRI line 572
- ICS down 573
- Trunk or Station Module down 574
- Data Module down 575
- Problems for network or remote users 576
 - Remote feature code gets no response 576
 - Dialed number gets ringback and the wrong person 576
 - Dialed number gets stuttered dial tone instead of ringback 577
 - Dialed number gets dial tone instead of ringback 578
 - Dialed number gets busy tone 578
 - Dialed number does not get through 579
 - Dialed DISA number gets ringback instead of stuttered dial tone 581
 - Dialed DISA number gets dial tone instead of stuttered dial tone 582
 - DISA user gets overflow tone when entering COS password 582
 - Dialed feature code gets overflow tone 584
 - Dialed feature code gets busy tone 585
 - Line pool access code gets overflow tone 585
 - Line pool access code gets ringback 586
 - Line pool access code gets busy tone 587
 - Dialed number gets no response 587

Specifications 589

- Norstar system 589
- Digital Trunk Interface 591

Glossary 593

Index 613

Backup programming overlays 655

Regulations

This equipment meets all applicable requirements of CSA and UL safety standards for North America and relevant EN60950 specifications for European markets.

Safety and installation



The shock hazard symbol within an equilateral triangle is intended to alert personnel to electrical shock hazard or equipment damage.

The following precautions should also be observed when installing telephone equipment.

- Never install telephone wiring during a lightning storm.
- Never install telephone jacks in wet locations unless the jack is specifically designed for wet locations.
- Never touch uninsulated telephone wires or terminals unless the telephone line has been disconnected at the network interface.
- Use caution when working with telephone lines.



The exclamation point within an equilateral triangle is intended to alert the user to the presence of important operating and maintenance (servicing) instructions in the literature accompanying the product.

This symbol (if applicable) on the product is used to identify the following important information:

For equipment with internal power supplies

- Mains nominal AC voltage 110-120 V~; 60Hz
- Mains nominal AC voltage 220-240 V~; 50Hz

For equipment with external power supplies

- Must be powered from an approved Class 2 power source.

For current ratings, refer to product specific documentation and product labels.

Important safety instructions

When using your telephone equipment, basic safety precautions should always be followed to reduce the risk of fire, electric shock and injury of persons, including the following:

- Follow the warnings and instructions marked on the product.
- Unplug this product from the wall outlet before cleaning. Do not use liquid cleaners or aerosol cleaners. Use a damp cloth for cleaning.
- Do not use this product near water, for example, near a bathtub, wash bowl, kitchen sink, or laundry tub, in a wet basement or near a swimming pool.
- Do not place this product on an unstable cart, stand or table. The product may fall, causing serious damage to the product.
- This product should never be placed near or over a radiator or heat register. This product should not be placed in a built-in installation unless proper ventilation is provided.
- Do not allow anything to rest on the power cord. Do not locate this product where the cord will be abused by persons walking on it.
- Do not overload wall outlets and extension cords as this can result in the risk of fire or electric shock.
- Never spill liquid of any kind on the product.
- To reduce the risk of electric shock, do not disassemble this product, but have it sent to a qualified service person when service or repair work is required.
- Unplug this product from the wall outlet and refer servicing to qualified service personnel under the following conditions:
 - a. When the power supply cord or plug is damaged or frayed.
 - b. If the product has been exposed to rain, water or liquid has been spilled on the product, disconnect and allow the product to dry out to see if still operates; but do not open up the product.

- c. If the product housing has been damaged.
- d. If the product exhibits a distinct change in performance.
- Avoid using telephone equipment during an electrical storm. There may be a remote risk of electric shock from lightning.
- Do not use the telephone equipment to report a gas leak in the vicinity of the leak.
- To eliminate the possibility of accidental damage to cords, plugs, jacks, and the telephone equipment, do not use sharp instruments during the assembly procedures.
- Do not insert the plug at the free end of the handset cord directly into a wall or baseboard jack. Such misuse can result in unsafe sound levels or possible damage to the handset.
- Disconnect telecommunications lines before unplugging main power cord.
- Save these instructions

North American regulations

MICS 6.0 and MICS-XC 6.0 meet all applicable requirements of both Industry Canada CS-03 and US Federal Communication Commission (FCC) part 68, and has been registered under files Industry Canada 332-5980-A and FCC-AB6CAN-20705-KFE (key system), AB6CAN-20706 MF-F/Hybrid, and AB6CAN-23740 PF-E (PBX System).

The CE marking on this equipment indicates compliance with the following EU directive: Directive 1999/5/EC - R&TTE

Federal Communication Commission (FCC) Notice Radio/TV interference

This equipment, has been tested and found to comply with the limits for a Class A digital device, pursuant to Part 15 of the FCC Rules. These limits are designed to provide reasonable protection against harmful interference when the equipment is operated in a commercial environment. This equipment generates, uses, and can radiate radio frequency energy and, if not installed and used in accordance with the instruction manual, may cause harmful interference to radio communications. Operation of this equipment in a residential area is likely to cause harmful interference in which case the user will be required to correct the interference at his own expense.

Changes or modifications not expressly approved by the party responsible for compliance could void the user's authority to operate the equipment.

Devices intended to be connected to the Public Switched Telephone Network



State and local requirements for support of Emergency 911 Dialing service by Customer Premises Equipment vary. Consult your local telecommunications service provider regarding compliance with applicable laws and regulations.

US

This telephone equipment complies with Part 68, FCC Rules for direct connection to the Public Switched Telephone Network (The FCC registration number appears on a label affixed to the ICS).

Your connection to the telephone line must comply with these FCC Rules:

- Use only an FCC Standard network interface jacks and FCC compliant line cord and plug to connect this equipment to the telephone line.
- If a network interface jack is not already installed in your location, you can order one from your telephone company. Order the following network jacks along with the corresponding Facility Interface Code (FIC):

Trunk Cartridge	REN	USOC	SOC	FIC
GATC LSDS (NT7B69AAAA) replacing Loop Start/Disconnect Supervision (LS/DS)- NT7B75GA-93	AC 1.5B DC 0.3	RJ21X	9.0F	02LS2
GATC CI (NT7B75AAC) replacing Call Information (CI)- NT5B41GA-93	AC 1.5B DC 0.3	RJ21X	9.0F	02LS2

Trunk Cartridge	REN	USOC	SOC	FIC
DTI (T1 or PRI) - NT7B74AAAA/ A0897902	—	RJ48C	6.0Y	04DU9- 1SN
E&M - NT5B38GA-93	—	RJ2HX	9.0F	TL32M
BRI-U2 and BRI-U4 Cards NT7B86GB-93 and NT7B87GB-93	—	RJ49C	6.0Y	02IS5
BRI-ST - NT7B76GY-93 (when connected to an NT1 which has a U interface to the telephone network)	—	RJ49C	6.0Y	021S5
DID - NT5B37GA-93	0.0B	RJ21X	AS.2	02RV2-T
Off-premise sets (OPX) - Analog Terminal Adapter	—	RJ11C	9.0F	0L13B



Notify service provider if DTI is disconnected.

You must notify your T1 service provider any time the 1.544 Mbps DTI interface is disconnected from the network.

In some states, customers are permitted to install their own jacks.

- The equipment cannot be used with or connected to a party line or a public coin phone service provided by the telephone company. Connection to Party Line Service is subject to state tariffs. Contact the Public State Utility Commission, Public Service Commission or Corporation Commission for information.
- It is no longer necessary to notify the Telephone Company of your system's Registration and REN numbers. However, you must provide this information to the telephone company if they request it.
- If this equipment causes harm to the telephone network, the telephone company will notify you in advance that temporary discontinuance of service may be required. If advance notice is not practical, the telephone company will notify the customer as soon as possible. Also, you will be advised of your right to file a complaint with the FCC if you believe it necessary.

- The telephone company may make changes in its facilities, equipment, operations or procedures that could affect the operation of the equipment. If this happens the telephone company will provide advance notice in order for you to make necessary modifications to maintain uninterrupted service.
- Do not attempt to repair this equipment yourself. If trouble is experienced with this equipment, please refer to the repair and warranty information, noted below. If the equipment is causing harm to the telephone network, the telephone company may request that you disconnect the equipment until the problem is resolved.
- Allowing Direct Inward Dial (DID) Equipment to be operated in such a manner as to not provide for proper answer supervision is a violation of Part 68 of the FCC Rules. Proper answer supervision is when:
 - a. This equipment returns answer supervision to the PSTN when DID calls are:
 - Answered by the called station
 - Answered by the attendant
 - Routed to a recorded announcement that can be administered by the CPE user.
 - Routed to a dial prompt
 - b. This equipment returns answer supervision on all DID calls forwarded to the PSTN. Permissible exceptions are:
 - A call is unanswered.
 - A busy tone is received.
 - A reorder tone is received.

Canada

Before installing this equipment, users should ensure that it is permissible to be connected to the facilities of the local telecommunications company. The equipment must also be installed using an acceptable method of connection. The customer should be aware that compliance with the above conditions may not prevent degradation of service in some situations.

Repairs to certified equipment should be made by an authorized Canadian maintenance facility designated by the supplier. Any repairs or alterations made by the user to this equipment, or equipment malfunctions, may give

the telecommunications company cause to request the user to disconnect the equipment.

Users should ensure for their own protection that the electrical ground connections of the power utility, telephone lines and internal metallic water pipe system, if present, are connected together. This precaution may be particularly important in rural areas.



Caution

Users should not attempt to make such connections themselves, but should contact the appropriate electric inspection authority, or electrician, as appropriate

This Class A digital apparatus meets all requirements of the Canadian Interference-Causing Equipment Regulations as specified in the Industry Canada Standard ICES-003.

Signaling method

The equipment allows signaling in DTMF tones. It can complete calls to local and long distance lines and can also complete long distance calls via computer phone systems such as MCI or SPRINT. This equipment is capable of providing access to interstate providers of operator services through the use of access codes. Modification of this equipment by call aggregators to block access dialing codes is a violation of the Telephone Operator Consumers Act of 1990.

Ringer Equivalence Number

US

The FCC Registration information on the product label, includes a Ringer Equivalence Number (REN) which is used to determine the number of devices you may connect to your phone line. A high total REN may prevent ICSs from detecting ringing in response to an incoming call and may make placing calls difficult. In most, but not all areas, the sum of the RENs should not exceed five (5.0). To be certain of the number of devices that may be connected to a line, as determined by the total RENs, contact the local telephone company.

Note: RENs are associated with loop start and ground start ports. Do not use for E&M or digital ports.

Canada

The Ringer Equivalence Number (REN) assigned to each terminal device provides an indication of the maximum number of terminals allowed to be connected to a telephone interface. The termination on an interface may consist of any combination of devices subject only to the requirement that sum of the ringer equivalence numbers of all the devices does not exceed 5.

Hearing aid compatibility

The telephone station sets are compatible with hearing aids equipped with an appropriate telecoil and is compliant with the requirements of the Americans with Disabilities Act (ADA).

Use of a music source

In accordance with US, Canadian and international copyright laws, a license may be required from the American Society of Composers, Authors and Publishers, or other composers' or performing rights organization if Radio, TV or other broadcasts to the public are transmitted through the Music On Hold or Background Music features of this telecommunication system.

Programming emergency numbers

When programming emergency numbers and/or making test calls to emergency numbers:

1. Remain on the line and briefly explain to the dispatcher the reason for calling before hanging up.
2. Perform such activities in the off-peak hours, such as early mornings or late evenings.

Substitution of non-approved equipment will void the NORTEL warranty.

Address for warranty and repairs in the US:

Nortel
640 Massman Drive
Nashville TN 37210

Address for warranty and repairs in Canada:

Nortel
30 Norelco Drive
Weston, Ontario M9L 2X6

For more information call 1-800-4NORTEL.

CE marking

The Industry Canada label identifies certified equipment. This certification means that the equipment meets certain telecommunications network protective, operational and safety requirements. The Department does not guarantee the equipment will operate to the user's satisfaction.

How to use this document

This guide provides core installation and programming information for MICS 6.0 and MICS-XC 6.0 systems. If you are installing a MICS-XC system, also refer to the *Modular ICS Companion Installer Guide* for Companion installation and programming.

- The MICS system can be a mini (no expansion cartridge installed), a midi (installed with a two-port expansion cartridge), a maxi (installed with a six-port expansion cartridge), or a mega (Combination Fiber six-port Services Cartridges and Services cartridges) system. For more on the configurations, see *Connecting expansion modules* on page 224.

This version of the software does not support Companion.

- The MICS-XC system has all the functionality of MICS, plus it supports the Companion wireless functionality.

Both systems support ISDN PRI and BRI, and T1 functionality. All MICS 6.0 functionality is described in this book. For system coordinators, the *MICS 6.0 System Coordinator Guide* explains how to perform common telephone programming.

Companion wireless programming and installation instructions are documented in the *Modular ICS Companion Installer Guide* and the *Modular ICS Companion System Coordinator Guide*.

Information that is specific to MICS-XC systems or MICS systems is clearly marked within this guide.

Note: Throughout this guide, reference to KSU refers to the Integrated Communication System (ICS).

What's new with Norstar

The Norstar 0X32 MICS 6.0 includes several new features and a few functionality changes.



To upgrade from any previous version of MICS software to MICS 6.0, refer to *Upgrading your Norstar system* on page 189 for detailed instructions.

New features for version 6.0

- Distinctive ring for lines and hunt groups

You can now assign distinctive ring patterns (DRP) to both lines and hunt groups. This is similar to the feature that allows you to assign different rings to your telephone so you can distinguish which phone is ringing. All three of these features work in concert with each other. Which ring will be used depends on the priority that is assigned to each, and the order in which the assignment occurred. Refer to *Programming distinctive ring patterns* on page 348 and *Assigning a distinctive ring pattern to a Hunt Group* on page 392.

- System wide call appearance feature codes (SWCA)

Sixteen new feature codes allow you to assign indicator memory buttons with SWCA codes. These buttons provide call appearance for both incoming and outgoing calls to any group of telephones with the same assigned buttons. This allows a call to be parked on a SWCA button, and then the call can be retrieved by any other member of the group.

Calls are assigned to the SWCA buttons, either automatically or manually, at the telephone that receives or makes the call. This frees up the line for other calls while maintaining an appearance of the call in the group. Refer to *Setting SWCA controls* on page 403.

- CLID display enhancements:
 - alpha tagging using system speed dial name and CLID match
 - system speed dial codes increased to 255
 - Caller ID indicated for telephone rather than for individual lines

Alpha tagging is an enhancement to the CLID functionality of the system. This feature matches incoming call numbers with system speed dial entries. If enough digits match (CLID match), and the telephone is set to receive caller names (Caller ID set), then whatever name is entered into the system speed dial for that number will display when the call comes in. Refer to *Sys speed dial* on page 381.

Note: Alpha tagging activates when the CO line service supplies only a number for the incoming call. Otherwise, the system uses the name supplied by the CO line service.

To support this feature, the system speed dial codes have been increased to 200 entries, with three-digit codes from 001 to 255. Refer to the *MIC ICS 6.0 System Coordinator Guide* for a detailed description of System Speed dial programming.

- off-core DTI for profiles 1 and 4, allowing additional PRI lines (new line pool)

Profile 1 and 4 customers can now add an additional DTI card to their midi (module 3 or 4) and maxi systems (module 7 or 8) to provide extra T1 or PRI lines to their system. Since the card uses all available lines on the module, no other cards can be installed into the module with this card.

- Further enhancements have been made to MCDN functionality, which is supported in profiles 1, 2, and 3.
 - TAT Refer to *Trunk Anti-tromboning* on page 140.
 - ICCL Refer to *ISDN Call Connection Limitation* on page 136.
 - Centralized voice mail and auto attendant on Norstar Voice Mail platform
 - Centralized voice mail provided by Meridian Mail provides attendant features: camp-on (*Camp-on* on page 142) and break-in (*Break-in* on page 143)).

Functionality changes for version 6.0

- Profile 2: This profile has been adjusted to accommodate systems which use ETSI PRI lines with an a-law companding protocol.
 - The off-core DTI module is not supported on this profile.
 - T1 functionality has been removed from this profile.
 - The PRI SL-1 MCDN protocol, and all the networking features this protocol supports, is supported on this system. Refer to *MCDN services (profiles 1, 2, 4)* on page 445.

- As well, the EURO PRI protocol is supported for this profile.
- In addition, the central office ETSI PRI features: Network Call Redirection and Malicious Caller ID (MCID) can be used if they are allowed by your service provider. Refer to *ETSI: Network diversion and MCID (profile 2 only)* on page 442.
- Line renumbering: Due to the addition of ETSI to Profile 2, the line numbering for the entire system has been realigned to accommodate the extra lines provided by ETSI lines. When you perform an upgrade, existing line assignments will be automatically updated. Refer to *Trunk module line numbering* on page 205 for a comparison table of line numbering based on software versions. Refer to *TrunkMod* on page 467 for detailed line numbering based on the type of trunk module that is installed. This change includes the target line numbers.
- Due to the expansion of the system speed dial feature codes up to 255, the user speed dial list has been changed to codes 256 to 279 (24 codes, no change from existing systems). Refer to *User preferences* on page 321.

Welcome to ISDN

This chapter provides you with some background information about ISDN, including information about:

- analog vs. ISDN
- type of ISDN service
- ISDN layers
- ISDN bearer capability
- services and features for ISDN PRI and BRI
- ISDN hardware
- ISDN standards compatibility

Integrated Services Digital Network (ISDN) technology provides a fast, accurate, and reliable means of sending and receiving voice, data, images, text, and other information through the telecom network.

ISDN uses existing analog telephone wires. The signal on the wire gets divided into separate digital channels, which dramatically increases the bandwidth.

ISDN uses a single transport to carry multiple information types. What once required separate networks for voice, data, images, or video conferencing is now combined on to one common high-speed transport.

Note: Nortel endeavors to test all variations of ISDN BRI and PRI on Norstar. However, due to the number of variations, this is not always possible. Check with your service provider about compatibility.

Comparing ISDN to Analog

ISDN offers significantly higher bandwidth and speed than analog transmission because of its end-to-end digital connectivity on all transmission circuits. Being digital allows ISDN lines to provide better quality signaling than analog POTS (plain ordinary telephone) lines. Also ISDN out-of-band data channel signaling offers faster call setup and tear down.

While an analog line carries only a single transmission at a time, an ISDN line can carry one or more voice, data, fax and video transmissions simultaneously.

An analog modem operating at 14.4 K takes about 4.5 minutes to transfer a 1MB data file and a 28.8K modem takes about half that time. Using one channel of an ISDN line, the transfer time is reduced to only one minute. If two ISDN channels are used, transfer time is just 30 seconds.

When transmitting data, the connect time for an average ISDN call is about three seconds per call, compared to about 21 seconds for the average analog modem call.

Type of ISDN service

Two types of ISDN services (lines) are available: Basic Rate Interface (BRI) and Primary Rate Interface (PRI). Each line is made up of separate channels known as B and D channels which transmit information simultaneously.

- BRI is known as 2B+D because it consists of 2 B-channels and one D-channel.
- PRI is known as 23B+D because it consists of 23 B-channels and one D-channel.

B channels

B channels are the bearer channel. They are used to carry voice or data information and have speeds of 64 kbps. Since each ISDN line (BRI or PRI) has more than one B-channel, more than one transmission can occur at the same time, using a single ISDN line.

D channels

The standard signaling protocol is transmitted over a dedicated data channel called the D-channel. The D-channel carries call setup and feature activation information to the destination. This channel has speeds of 16 kbps (BRI) and 64 kbps (PRI). Data information consists of control and signal information and packet-switched data such as credit card verification.



Tip - *Norstar PRI supports the D-channel on the 24th channel only. Norstar does not include support for a backup D-channel on the span.*

ISDN layers

ISDN layers refer to the standards established to guide the manufacturers of ISDN equipment. The layers include both physical connections, such as wiring, and logical connections, which are programmed in computer software.

When equipment is designed to the ISDN standard for one of the layers, it works with equipment for the layers above and below it.

There are three layers at work in ISDN for Norstar. To support ISDN service, all three layers must be working properly.

Layer 1: A physical connection that supports fundamental signaling passed between the ISDN network (your service provider) and the Norstar ICS. When a DTI card configured as BRI or PRI is used for a network connection, the LED for the loop on the card is lit when the layer 1 is functioning.

Layer 2: A logical connection between the ISDN network (your service provider) and the Norstar ICS. Norstar has two of these connections for each BRI line, one for each of the logical lines. Without Layer 2, call processing is not possible, and there is no dial tone.

Layer 3: Also a logical connection between the ISDN network (your service provider) and the Norstar ICS. For BRI lines, layer 3 is where call processing and service profile identifier (SPID) information is exchanged. This controls which central office services are available to the connection. For example, a network connection can be programmed to carry data calls.

The system of layers is important when you are installing, maintaining, and troubleshooting an ISDN system. See *Problems with BRI service* on page 570 for more information about working with the layers.

ISDN bearer capability

Bearer capability describes the transmission standard used by the BRI or PRI line that allows it to work within a larger ISDN hardware and software network.

The bearer capability for BRI and PRI is voice/speech at 3.1 kHz audio, and data at unrestricted 64 kbps, restricted 64 kbps, 56 kbps.

Services and features for ISDN PRI and BRI

As part of an ISDN digital network, your Modular ICS supports enhanced capabilities and features, including:

- faster call setup and tear down
- high quality voice transmission
- dial-up Internet and local area network (LAN) access
- video transmission
- network name display
- name and number blocking (PRI, BRI and analog)
- access to public protocols (only NI-1 for BRI)

PRI services and features

- call by call service selection
- dialing plan
- Emergency 911 dialing, internal extension number transmission
- Advanced Private Networking to Meridian 1 using SL-1 protocol, providing
 - access to central Voice Mail and Automated Attendant equipment connected to the Meridian system
 - trunk route optimization (TRO)
 - Message Waiting Indication (MWI) from the Voice Mail application
 - Network Call Redirection Information (NCRI), which is built on the existing Call Forward and Call Transfer features
- tandem networking between Norstar systems

BRI services and features

- data transmission at speeds up to 128 kbps per loop, depending on the bandwidth supported by your service provider
- shared digital lines for voice and data ISDN terminal equipment

Norstar Basic Rate Interface (BRI) cards also support D-channel packet service between a network and terminal connection. This allows you to add applications such as point-of-sale terminals without additional network connections.

Any analog or digital network connections can be shared by all Norstar telephones, peripherals and applications, and ISDN terminal equipment (TE).

Modular ICS supports the following ISDN services and features offered by ISDN service providers:

- D-channel packet service (BRI only) to support devices such as transaction terminals. Transaction terminals are used to swipe credit or debit cards and transmit the information to a financial institution in data packets.
- calling number identification, which appears on both Norstar sets and ISDN terminal equipment with the capability to show the information
- Multi-Line Hunt or DN Hunting which switches a call to another ISDN line if the line usually used by the Network DN is busy. (*BRI only*)
- subaddressing of terminal equipment (TE) on the same BRI loop. However, terminal equipment which supports sub-addressing is not commonly available in North America. (*BRI only*)

Transmission of B-channel packet data is not supported by Modular ICS.

Contact your ISDN service provider for more information about these services and features. Packages for ISDN service in North America are described on page 56.

The terminal equipment (TE) connected to the Norstar system can use some feature codes supported by the ISDN service provider. Refer to *ISDN services and features* in the *Modular ICS 6.0 System Coordinator Guide* for more information.

Feature descriptions

The following section provides brief descriptions about the ISDN features, and links for more programming information.

Network name display

This feature allows ISDN to deliver the Name information of the users to those who are involved in a call that is on a public or private network. For information on system programming of this feature see, *BusName* on page 429.

Systems with Advanced Private Networking connections (MCDN SL-1) to a Meridian system also retain information about sets that have forwarded or transferred a call, as well as the originating caller information. This feature is called Network Call Redirection Information (NCRI). This information is available to all parties involved in the call.

Calls can only be redirected a defined number of times within the network. This is currently hardcoded to five times. Once this limit is reached, call redirection will be disallowed regardless of the type of outgoing line being presented for redirection.

Instead, the call will be handled in one of these ways:

- If Call Forward on Busy is programmed, the call will ring if a free key is available. Otherwise, it goes to the Prime set. DND Busy programming is ignored.
- If Call Forward All Calls is programmed, the call will go to the Prime set.
- If Call Forward No Answer is programmed, the call will continue to ring at the destination.

Note: If a terminal rejects a call, the call goes to the Prime set, if a Prime set is configured for the target line. If the target line is configured to send a busy tone, the call gets released with the reason as *User Busy*.

Message Waiting Indicator (MWI)

Systems with Advanced Private Networking connections to a Meridian system Voice Mail system provide message-waiting indicators at telephones connected to those lines. Telephones with displays display a message. Non-display terminals may have a lamp that lights when a message is waiting. The setting for this feature is defined from the Meridian system.

Name and number blocking

This feature suppresses the outgoing name and/or number on a call by call basis. For information on system programming of this feature see, *Outgoing Name and Number Blocking* on page 432.

External call forwarding

The system now allows you to forward calls to an external number. This feature is activated using 4 from the telephone.

MCDN trunk features

Systems with MCDN Private Networking connections can provide these trunk routing features:

- Trunk Route Optimization (TRO) finds the most direct route through the network to send a call between nodes. This function occurs during the initial alerting phase of a call.
- ISDN Call Connection Limitation: The ICCL feature piggybacks on the call initiation request and acts as a check at transit PBX points to prevent misconfigured routes or calls with errors from blocking channels.
- Trunk Anti-tromboning (TAT) is a call-reroute feature that works to find better routes during a transfer of an active call. This feature acts to prevent unnecessary tandeming and tromboning of trunks. This action occurs after the speech path has been established.

Call by Call service selection for PRI

Call by Call service selection allows a user to access services or private facilities over a PRI line without the use of dedicated facilities. Various types of services such as FX, Tie, and OUTWATS are available, depending on the Protocol that is selected. Private network settings are used for tandem networking and Advanced Private Networking.

Outgoing calls are routed through a dedicated PRI Pool and the calls can be routed based on various schedules.

For information about system programming of this feature, see *Programming Call by Call service selection* on page 436.

For services information about dialing plans and PRI, see *Networking with Norstar* on page 91 and *Dialing Plan* on page 412.

Refer to the hardware section for *Call-by-call routing* on page 458.

Emergency 911 dialing

Modular ICS 6.0 with the ISDN PRI feature is capable of transmitting the telephone number and internal extension number of a calling station dialing 911 to the Public Switched Telephone Network.

State and local requirements for support of Emergency 911 dialing service by Customer Premises Equipment vary. Consult your local telecommunications service provider regarding compliance with applicable laws and regulations. For most installations, the following configuration rules should be followed, unless local regulations require other settings.

- All PSTN connections must be over PRI.
- In order for all sets to be reachable from the Public Safety Answering Point (PSAP), the system must be configured for DID access to all sets. In order to reduce confusion, the dial digits for each telephone should be configured to correspond to the extension number (DN).
- The OLI digits for each telephone should be identical to the DID dialed digits for the telephone.
- The System Coordinator is responsible for maintaining a site map or location directory that allows emergency personnel to rapidly locate a telephone given its DID number. This list should be kept up to date and readily available, and can be included in the Programming Record

- The routing table should route 911 to a public line or line pool.
- If attendant notification is required, the routing table must be set up for all 911 calls to use a dedicated line which has an appearance on the attendant console.

Note: The actual digit string 911 is not hard-coded into the system. More than one emergency number can be supported

MCID (Profile 2)

The MCID feature allows you to use to have call information recorded on the central office database for an incoming call on a specific line (EUROISDN lines, only).

The user must invoke the feature code during the active call or within 30 seconds (time varies on different networks) after the caller hangs up. The user must remain on the line to enter the code.

Network Call Diversion (Profile 2)

This feature is a network function of ETSI E1 lines that allows forwarding and redirection of calls outside the Norstar network when using an ETSI ISDN line. Functionality is similar to that of External Call Forward (ECF). NCD redirects calls using the same line on which they arrive. Call forward is efficient since there is no need for additional outside lines.

DTI card configured as a PRI card

The DTI card on your Norstar system can be configured to support PRI. For information on configuring a DTI card as a PRI type card, see *Provisioning the DTI card for PRI* on page 456.

ISDN hardware

To support connections to an ISDN network and ISDN terminal equipment, your Modular ICS must be equipped with one or more BRI Cards (BRI-U or BRI-ST), a DTI card configured for PRI, and a Combination Fiber 6-port Services Cartridge or a Services Cartridge.

DTI Card configured as PRI

A DTI card configured as PRI provides one T loop. Refer to *T reference points* on page 51 for more information.

In most PRI network configurations, you need one DTI card configured as PRI in your ICS to act as the primary clock reference. The only time when you may not have PRI designated as the primary clock reference is in a network where your Norstar system is connected back-to-back with another switch using a PRI link, such as is the case with the Advanced Private Networking configuration.

However, if the other switch is loop-timed to your Norstar system, your DTI card, configured as PRI, can be designated as a timing master.

If your Norstar has two DTI cards configured as PRI, you cannot assign both cards as the primary reference or both cards as the secondary reference. You can only have one primary reference and one secondary reference per system. Refer to *ClockSrc* on page 464 for more information.

BRI Card

The loops on BRI-U and BRI-ST cards can be programmed to support either network or terminal connections. This allows you to customize your arrangement of lines, voice terminals, data terminals and other ISDN equipment.

Detailed wiring information for BRI and PRI network and terminal connections is included in the *Installation* on page 209.

BRI-U2 and BRI-U4 card

A BRI-U2 card supports two loops and the BRI-U4 supports four loops. Each loop can be individually programmed to provide one of the following:

- a U-LT reference point connection for terminal equipment (TE) with built-in NT1 functionality (U interface)
- a U-NT reference point connection for direct connection to an ISDN network

BRI-ST card

A BRI-ST card provides four loops. Each loop can be individually programmed to one of the following:

- an S reference point connection (S loop) to ISDN terminal equipment (TE)
- a T or S reference point connection (T loop or S loop) to an ISDN network using an external NT1

U-LT reference point

The U-LT reference point connection provides a point-to-point digital connection between Norstar and TE equipped with a U interface.

A U-LT loop supports up to eight ISDN DN_s, which identify TE to the ICS.

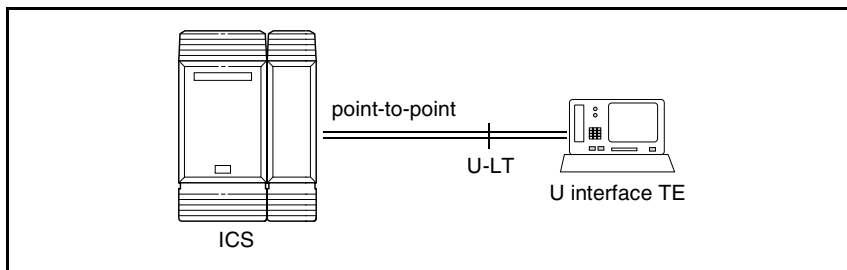

U-NT reference points

The U-NT reference point connection provides a point-to-point digital connection between the ISDN network and the ICS.

A U-NT loop provides lines that can be used by all Norstar telephones, peripherals and applications, and ISDN TE.

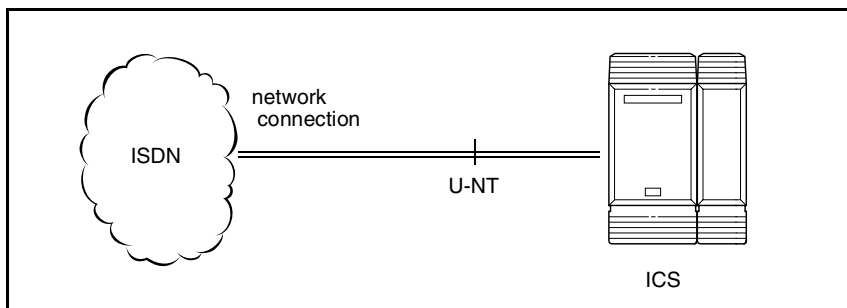

U-NT and U-LT loops can be used in combination to provide D-packet service for a point-of-sale terminal adapter (POSTA) or other D-packet device. D-packet service is a 16 kbps data transmission service that uses the D-channel of an ISDN line.

To deliver D-packet service, a network connection (U-NT) is programmed to work with a terminal connection (U-LT). The loops must be on the same physical card. For example, if the

network connection is a loop found on the BRI Card in Slot 1, the terminal connection must be a loop found on the same card.

S reference point

The S reference point connection provides either a point-to-point or point-to-multipoint digital connection between Norstar and ISDN terminal equipment (TE) that uses an S interface.

S loops support up to seven ISDN DNs, which identify TE to the ICS.

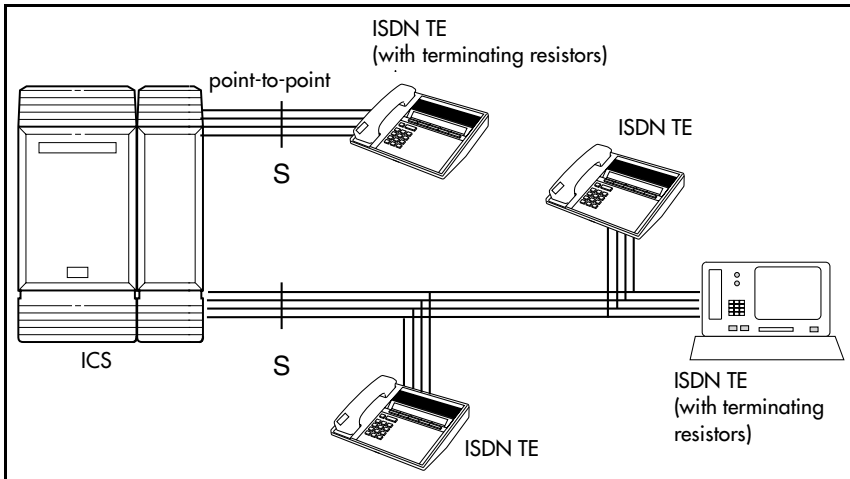

T reference points

The T reference point connections provide a point-to-point digital connection between the ISDN network and Norstar.

A T loop provides lines that can be shared by all Norstar telephones, peripherals and applications, and ISDN TE.

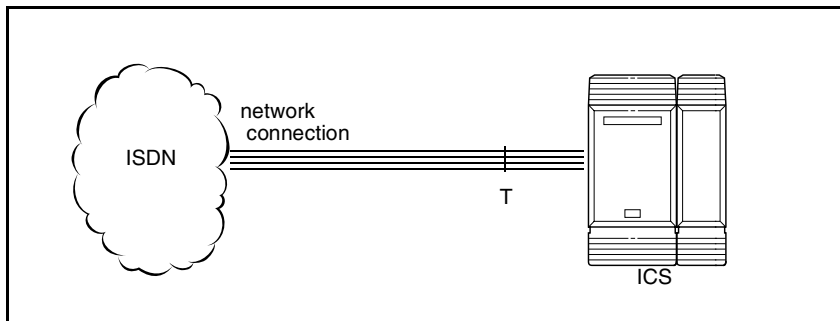

A T loop can be used in combination with an S loop to provide D-packet service for a point-of-sale terminal adapter (POSTA) or other D-packet device. D-packet service is a 16 kbps data transmission service that uses the D-channel of an ISDN line.

To deliver D-packet service, a network connection (T loop) is programmed to work with a terminal connection (S loop). The loops must be on the same physical card. For example, if the network connection is a loop found on the BRI Card in Slot 1, the terminal connection must be a loop found on the same card

Clock source for ISDN cards

Systems with ISDN interfaces need to synchronize clocking with the ISDN network and any connected ISDN terminal equipment. Clocking synchronization is supported by either a Combination Fiber 6-port Services Cartridge or a Services Cartridge.

The Modular ICS derives timing from the network using U-NT and T reference points (loops). Terminal equipment on U-LT and S reference points (loops) derive timing from the ICS.

Systems synchronize clocking to the first available, functional, network connection. If there are excessive errors on the

reference network connection, or the loop fails, the next available, functional, network connection is used for clock synchronization.

The clock synchronization process generates alarm codes and event messages. See the *Alarm codes* on page 506 and *Event messages* on page 514 for more information.

When you configure the network connections to the Modular ICS, you should take into account the system preferences for selecting loops for synchronization:

- lower numbered loops have preference over higher numbered loops
- the loop preference order is: 201, 202, 203, 204, 225, 226, 227, 228
- the system skips U-LT, S, and analog loops when selecting a network connection for synchronization

Systems with only U-LT and S loops act as timing masters for the attached terminal equipment (TE), and are not synchronized to the network. ISDN TE without access to a network connection (BRI lines) has limited or no functionality.

If your system has both a BRI and a DTI card configured as PRI installed, it is recommended that you use PRI as the primary clock source, see *DTI card configured as a PRI card* on page 47.

Other ISDN BRI equipment: NT1

The NT1 (network termination type 1) connects an S interface (four-wire) to a U interface (two-wire). In most cases, it connects loops from a BRI-ST card to the network connection, which uses the U interface. It can also connect S interface terminal equipment (TE) to the U loop from a BRI-U2 or BRI-U4 Card.

An NT1 is not required to connect from the network to BRI-U Cards or to connect U interface TE to an ICS equipped with BRI-U Cards.

The NT1 converts and reformats data so it can be transmitted to and from the S or T connection. In addition, it manages the maintenance messages travelling between the network and the NT1, and between the NT1 and the ICS.

The NT1 from Nortel Networks is packaged two ways:

- a stand alone package which contains one NT1 card (NTBX80XX) and a power supply (NTBX81XX)
- a modular package which contains up to 12 NT1 cards (NTBX83XX) and a power supply (NTBX86AA)

ISDN standards compatibility

Norstar ISDN equipment supports National ISDN standards for basic call and calling line identification services.

Norstar BRI is compliant with National-1 and PRI is compliant with National-2.

Modular ICS does not support EKTS (Electronic Key Telephone System) or CACH (Call Appearance Call Handling).

Working with ISDN

Planning your ISDN network

Consult *ISDN hardware* on page 48 and *ISDN programming* on page 58 to determine a configuration of ISDN trunks and terminal equipment (TE) for the Modular ICS, then order the appropriate ISDN capability package from your ISDN service provider.

For ISDN BRI service your service provider supplies service profile identifiers (SPIDs), network directory numbers (Network DNs), terminal endpoint identifiers (TEIs), and other information, as required, to program your Modular ICS, TE and other ISDN equipment.

Modular ICS does not support any package with EKTS (Electronic Key Telephone System) or CACH (Call Appearance Call Handling). EKTS is a package of features provided by the service provider and may include features such as Call Forwarding, Link, Three-Way Calling, and Calling Party Identification.

Ordering ISDN PRI

When you order ISDN PRI, order two-way DID because it simplifies provisioning and provides efficient use of the PRI bandwidth.

Ordering ISDN PRI service in Canada

In Canada, order Megalink™ service, the trade name for standard PRI service and set the Norstar equipment to the supported protocol that is identified by your service provider, either DMS-100 or NI-2.

Ordering ISDN PRI service in United States

In the United States order PRI service from your service provider. Set the Norstar equipment to the PRI protocol provided by your service provider.

Ordering ISDN BRI

Ordering service in Canada

In Canada, order Microlink™ service, the trade name for standard BRI service. You can order either regular Microlink™ service, which includes the CLID (Calling Line Identification) feature, or Centrex Microlink™, which includes access to additional ISDN network features (including Call Forwarding).

When ordering Microlink™ service, it must be ordered with EKTS (Electronic Key Telephone System) turned off. If you will be using a point-of-sale terminal adapter (POSTA), ask for D-packet service to be enabled.

Ordering ISDN service in the U.S.

In the U.S., regardless of the CO (Central Office) type, order National ISDN BRI-NI-1 with EKTS (Electronic Key Telephone System) turned off. Use the following packages as a guideline for ordering your National ISDN BRI-NI-1.

However we recommend using packages M or P with the Modular ICS. Contact your service provider for more information about the capability packages it offers.

Bellcore/National ISDN Users Forum (NIUF) ISDN packages supported by Modular ICS (for ordering in U.S.)

	Capability	Feature set	Optional features	Point -of-sale	Voice	Data
M	Alternate voice/circuit-switched data on both B-channels	--	calling line identification	--	✓	✓
P	Alternate voice/circuit-switched data on both B-channels D-channel packet	flexible calling for voice (not supported by Modular ICS) Basic D-Channel Packet	additional call offering (not supported by Modular ICS) calling line identification	✓	✓	✓

If you want to transmit both voice and data, and support D-channel packet service, order package P. However, Modular ICS does not support the flexible calling for voice and additional call offering features that are included in package P.

Multi-Line Hunt may be ordered with your package. When a telephone number (the Network DN) in the group of numbers assigned by your service providers is busy, the Multi-Line Hunt feature connects the call to another telephone number in the group. Norstar supports the feature only on point-to-point, network connections (T loop or U-NT loop). Check with your service provider for more information about Multi-Line Hunt.

Any of the ISDN packages will allow you to use sub-addressing, but your ISDN TE must be equipped to use sub-addressing for the feature to work.

Supported ISDN protocols

The switch used by your service provider must be running the appropriate protocol software and the correct version of that software to support ISDN PRI and ISDN BRI. Each protocol is different and supports different services. Contact your service provider to ensure that your ISDN connection has the protocol you require.

For more information on the supported protocols and services, refer to *Call by Call service selection for PRI* on page 433.

ISDN programming

Most of the configuration programming for PRI and BRI lines and ISDN terminals and devices is done under Hardware. This section gives you an overview of programming for PRI and BRI lines, ISDN terminals and devices, and D-packet service.

PRI or BRI programming activity	Programming heading
View or change the card configuration for each slot in the ICS	Hardware
Provision or deprovision loops and lines	Provisioning
Enable or disable BRI or DTI card (PRI)	Module status
View status of line, loop or port	Port/DN status
Enable/disable individual PRI channels	Link Status

Programming ISDN PRI resources

Some steps will not be necessary, depending on the service you are providing.

More detailed information is included under the individual headings and settings in the Programming and Maintenance sections.

For complete card and cartridge installation instructions and safety precautions, see *Installation* on page 209.

1. Collect the information supplied by your service provider to support your ISDN package.
2. Ensure that a Combination Fiber 6-port Services Cartridge, or a Services Cartridge has been installed in the ICS.
3. Install the DTI cards in the ICS. Refer to *Installing the cartridges* on page 213 for information about card placement. If you are not using DTI cards, determine which type of card you will preprogram the ICS to use in each slot.



Tips - A new DTI card being released with MICS 6.0 can be installed off-core on Module 3 or 4 on the Midi system, or module 7 or 8 on the Maxi system to expand the PRI capability of your system. This card is only support on Profile 1 and 4.

4. Disable each card under **Maintenance**.
5. Select a card type (PRI) in **Hardware**. See *Provisioning the DTI card for PRI* on page 456, for information on protocol and other settings you must configure.



Tips - If you are using one or more of the lines on this card for MCDN private networking, this is where you specify that protocol (SL-1).

6. Re-enable the card in **Maintenance**.

If required, the card goes through a firmware download process, which takes five to six minutes. During a firmware download, the bottom LED on the DTI card flashes.

Programming ISDN BRI resources

Some steps will not be necessary depending on the service you are providing.

More detailed information is included under the individual headings and settings in the Programming and Maintenance sections.

For complete card and cartridge installation instructions and safety precautions, see *Installation* on page 209.

1. Collect the information supplied by your service provider to support your ISDN package. This includes network service profile identifiers (SPIDs) and Network DNs. If you are supporting a point-of-sale terminal adapter, you also need one or more terminal endpoint identifiers (TEIs).
2. Make sure a Combination Fiber 6-port Services Cartridge, or a Services Cartridge has been installed in the ICS.
3. Install the BRI card in the ICS, Trunk Module. Refer to *Installing the cartridges* on page 213 for information about BRI card placement. If you are not using a BRI card, determine which type of card you will preprogram the ICS to use in each slot.
4. Disable each card in **Maintenance** under **Module Status**.
5. Under **Hardware**, select a card type: BRI-ST, BRI-U2, BRI-U4.
6. Under **Hardware**, select the type for each loop:
 - for a BRI card, select T or S if the card type is BRI-ST
 - for a BRI-U2 or BRI-U4 card, select LT or NT

7. If the card uses a T or NT loop, enter the following information, as supplied by your service provider:

- the SPID assigned to the loop
- the number of B-channels associated with each SPID
- the Network DNs used with the network SPID
- the call type of the Network DN

Repeat the programming for the second network SPID, if any.

If the T or NT loop is used for D-packet service:

- turn on the service
- assign the appropriate S-loop mapping for BRI-ST cards or LT-loop mapping for BRI-U2 or U4 cards
- assign the TEIs to the loop. These are provided by the telco to support a point-of-sale terminal adapter or other D-packet service device.

If the loop type is S, select the sampling used on the loop.

If the loop type is S or LT:

- assign ISDN DNs to the loop
- designate one of the assigned ISDN DNs to be the DN for the loop (Loop DN).

Note: You can have a maximum of 30 ISDN DNs on your system. The default ISDN DN range is 667–696 for a system with three-digit DNs. To change ISDN DN type, see *Change DNs* on page 397.

8. Re-enable the card in **Maintenance**. Refer to *Disabling a PRI Channel* on page 524.

If required, the card goes through a firmware download process, which takes five to six minutes. During a firmware download, the bottom LED on the BRI card flashes.

9. Provision the loops and lines, as appropriate, in **Maintenance**. Refer to *Provisioning BRI and PRI lines* on page 522.
10. If you are configuring auto-answer BRI trunks to map to target lines, program the received number for the target line to be the same as the Network DN supplied by your service provider. This setting is found under **Lines**.

Assign the ISDN lines and target lines to the appropriate ISDN DNs, which are the set of DNs reserved for use by ISDN devices. This setting is found under **Terminals&Sets/Line access**. ISDN lines can also be assigned to the DNs used by the telephones or any other devices connected to the Modular ICS.

Program the ISDN terminals and devices with the appropriate ISDN DNs and terminal SPIDs by following the instructions that come with the devices. For more information, see *Programming ISDN equipment* on page 65.

If you are setting up a D-packet service, program the point-of-sale terminal adapter or other D-packet service device with the appropriate TEI (provided by your service provider), terminal SPID, and DN by following the instructions that come with the device.

Programming ISDN PRI lines

When the configuration programming under **Hardware** is complete, your PRI lines are ready to be programmed. For information on programming your PRI lines, see *Call by Call service selection for PRI* on page 433.

Programming ISDN BRI lines

When the configuration programming under **Hardware** is complete, your BRI lines are ready to be programmed in the same way as analog lines. You can, for example, place them in pools and assign them to Norstar telephones, Business Series Terminals, or ISDN terminal equipment.

However, there are some differences in the way BRI lines work that will influence how you configure them to handle incoming and outgoing calls.

- For BRI lines, in most cases, your service provider supplies two SPIDs – one for each B channel. Each SPID and one or more Network DNs are associated with a single line. Calls to a Network DN come in on a specific line. Pressing a line button selects the same line every time.
- If your service provider supplies you with a single SPID for both B channels, incoming and outgoing calls are handled according to the loop. The two lines provided by the BRI loop are pooled for both incoming and outgoing calls.

For example, if Loop 201 is programmed with a single SPID, which supports lines 001 and 002, incoming calls made to a Network DN associated with the SPID appear on either line 001 or line 002. If you press the line button for line 001, either line 001 or line 002 is selected. For loops which use a single SPID, assign both lines on a loop to a telephone to guarantee that all calls appear at the telephone.

Programming Direct Inward System Access (DISA) on PRI trunks

When a trunk cartridge is set to PRI, all lines on that trunk are set to Auto Answer without Direct Inward System Access (DISA).

DISA can be accessed by one of two methods.

- 1) Define the DISA DN to match the trailing digits of the Called Party Number (CDN).

With Public, Private, and Tie service types, the CDN is simply truncated to the Target Line Receive Digit Length and is parsed to match the Target Line Receive Digits. DISA can be accessed by having the DISA DN match the trailing digits of the CDN. For example, with a Receive Digit Length = 4, and DISA DN = 1234, a call made to Public DN 763-1234 will be handled as follows:

- the ISDN setup message will contain a CDN of 763-1234
- the CDN will be truncated to the four digits, 1234
- 1234 matches the DISA DN
- the call will be answered with DISA

- 2) Use incoming Call by Call (CbC) Service routing to map the call type to the DISA DN. Refer to *Programming Call by Call service selection* on page 436 for more information.

With FX, INWATS, 900, and SDS service types, either a Service Id (SID) or a CDN is mapped to Target Line Receive Digits.

This is programmed under Call-by-Call Routing. DISA may be accessed by having the SID or CDN map to the DISA DN. This example has a Receive Digit Length = 4, DISA DN = 1234, and CbC Routing with (Service Type = FX, Map from SID = 2, Map to digits = 1234).

A call presented to the Norstar system with service type FX and SID 2 will be handled as follows:

- The ISDN setup message will specify FX with SID = 2
- The FX SID = 2 will be mapped to DISA DN digits 1234

The call will be answered with DISA

Programming ISDN equipment

DTI cards configured as PRI support various applications that are enabled by PRI. For a list of the type of applications that are support, see *ISDN applications* on page 173.

Terminal equipment for BRI cards

ISDN devices and terminals connected to the ICS must be configured under the Hardware heading in system programming. You choose directory numbers for ISDN equipment from a pre-determined range of DNs (667-696). Any of the ISDN DNs can be assigned to any U-LT or S loop, but each can only be assigned to one loop and one device.

Devices on an S or LT loop (BRI cards only)

Terminal equipment using a U-LT loop or S loop must be assigned an ISDN directory number (ISDN DN). This allows the TE to be assigned lines and to communicate with other devices connected to the ICS. Each DN can be assigned to only one TE and one loop.

You assign ISDN DNs to S loops and LT loops under **Assign DNs** under **Hardware**. Each S or LT loop can be programmed with eight ISDN DNs, but you cannot exceed a total of 30 ISDN DNs for the Modular ICS.

Once you have assigned ISDN DNs to a loop, designate one of the DNs as a Loop DN. The Loop DN acts as a main ISDN DN and completes the configuration of the loop.

The ISDN terminal equipment (TE) on the loop is also programmed with its ISDN DN. See the instructions that come with the ISDN device for information on how to program it to recognize the assigned DN. Most devices will require both a terminal service profile identifier (terminal SPID) and a DN, and some will require two terminal SPIDs and two ISDN DNs. The SPID used with the device should not be confused with a SPID used for network connections using an T or NT loop.

To create a terminal SPID for a device, add at least two zeros to the end of the of the ISDN DN. Add more zeros to the beginning or end of the ISDN DN until you have the length of SPID required by the TE. For example, if an ISDN telephone requires a six-digit SPID and has a DN of 667, its SPID is 066700. If the same TE requires a minimum of ten digits, the SPID is 0000066700.

Most ISDN terminals require a five-digit SPID. An ISDN PC card usually requires a 10-digit SPID. Follow the directions that come with the ISDN device to program it with a SPID and ISDN DN.

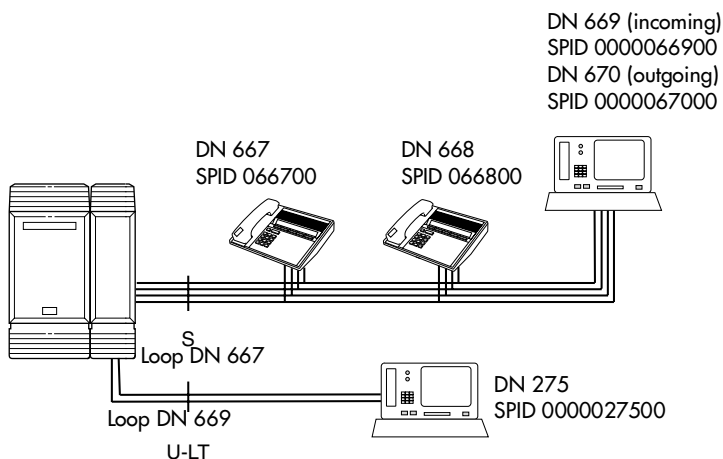

The following table uses the example in the illustration to show the programming for the S loop.

Setting	Option
Loop	201
Type	S
Sampling	Fixed
DNs on Loop 201: Assign DN	667: Assigned 668: Assigned 669: Assigned 670: Assigned
Loop DN	667

ISDN router

By connecting an ISDN router to your Modular ICS, a group of PCs can share Internet access. This arrangement is best for a workplace where each personal computer occasionally uses an Internet connection.

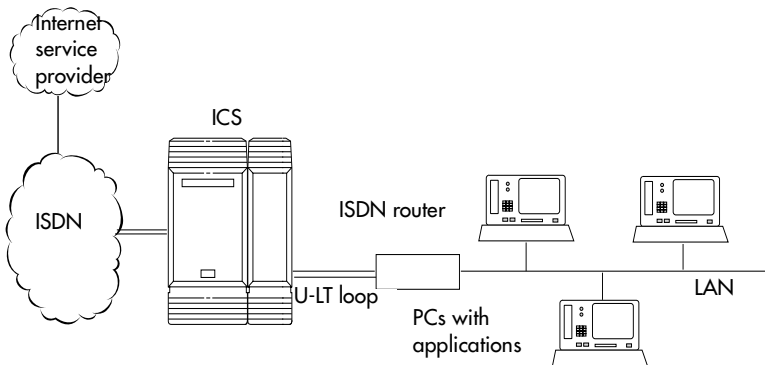

To support Internet access, you must order BRI lines from your service provider, and subscribe to an Internet service from an Internet service provider (ISP). Your personal computer must have an Internet browser and any applications supplied by your ISP.

D-packet service (BRI cards only)

The D-packet service supplied by the Modular ICS supports a point-of-sale terminal adapter (POSTA). Connecting a POSTA allows transaction terminals, such as devices where you swipe credit or debit cards, to transmit information using the D channel of the BRI line. At the same time, the B channels of the BRI line remain available for voice and data calls. A special adapter links transaction equipment, such as cash registers, credit card verification rigs, and point-of-sale terminals, to the X.25 network. This is a data communications network designed to transmit information in the form of small data packets.

To support the D-packet service, your ISDN network and financial institution must be equipped with a D-packet handler. To convert the protocol used by the transaction equipment to the X.25 protocol, your ISDN network must also be equipped with an integrated X.25 PAD.

X.25 PAD works with the following versions of X.25: Datapac 32011, CCITT, T3POS, ITT and API. The ISDN service package you order must include D-packet service, for example, Package P in the U.S. or Microlink™ with D-channel in Canada.

Your service provider supplies a Terminal Endpoint Identifier (TEI) and a DN to support D-packet service. The TEI is a number between 00 and 63 in the U.S. In Canada, the default range is 21-63. Your service provider may also supply you with a DN to program your D-packet device. The DN for D-packet service becomes part of the dialing string used by the D-packet to call the packet handler.

POSTA for ISDN BRI

When you configure D-channel packet service, you are specifying the transmission path between an ISDN loop on the network side of the ICS and the ISDN loop on the telephone side. The telephone side loop is the loop used by the point-of-sale terminal adapter. The service is turned on and configured using the network loop programming found under **Hardware**. Use NT loop for BRI-U2 and BRI-U4 cards and S or T loop for BRI-ST cards.

To set up D-packet service:

- go to the programming settings for the network loop under **Hardware**. (S, T, or NT loop)
- select the S loop or LT loop used by the POSTA
- enter the terminal endpoint identifiers (TEIs) supplied by your service provider

Point-of-sale terminal adapter

The point-of-sale terminal adapter is an analog device that connects to point-of-sale devices using an RS-232 interface and a U-LT loop. It handles the routing of packet information from the devices to the ICS and into the ISDN network.

Your service provider, usually a financial institution, supplies you with information about the compatible controller, which handles the routing of packet information from the devices to the ICS and into the ISDN network.

Trunks and target lines

Trunks are external lines that provide the physical connection between a Norstar system and other systems in a private or public network. Trunks are numbered 001 to 156 in a fully expanded system. Norstar Modular ICS supports six different types of trunks:

- PRI trunks are used for incoming and outgoing calls over an ISDN network. PRI SL-1 lines can provide MCDN network functionality in a private network between other Norstar systems, Meridian 1 systems, or Business Communications Systems, if the appropriate software code has been installed.
- T1 trunks are digital trunks that can be configured to act as loop start, ground start, E&M, DID, or leased lines, depending on your requirements.
 - DID trunks route incoming calls from the public network directly to telephones within Norstar, without an attendant.
 - Loop start trunks handle incoming and outgoing calls between Norstar and the public network.
 - E&M trunks handle incoming and outgoing traffic between the Norstar system and the private network.
- BRI trunks handle incoming and outgoing calls between Norstar and an ISDN network.
- Target lines are virtual communication paths between trunks and telephones on the Norstar system. They are incoming lines only, and cannot be selected for outgoing calls. With 192 target lines in a fully expanded system, you can concentrate auto answer calls on fewer trunks. This type of concentration is an advantage of target lines. Norstar mapping allows you to direct each target line to

one or more telephones. Target lines are numbered 157 to 348 in a fully expanded system, and 157 to 284 in all others.

Telephones can be configured to have an appearance of any type of trunk and line, including target lines, but excluding PRI trunks. If assigned, they are used for monitoring call usage.

Trunk operating modes (T1)

T1 trunks have four operating modes:

- ground start (T1 only)
- loopstart (analog and T1)
- E&M (analog and T1)
- DID (analog and T1)

Ground start trunks (T1 only)

Ground start trunks offer the same features as loop start trunks, but are used when the local service provider does not support disconnect supervision for the digital loop start trunks. Ground start trunks work with T1 only.

By configuring lines as ground start, the system will be able to recognize when a call is released at the far end.



Tips - *You cannot change the trunk mode for a ground start trunk on a DTI. It always has disconnect supervision.*

A DTI can provide a maximum of 24 ground start trunks. Analog ground start trunks are not supported.

DID trunks

DID trunks give you direct inward dialing (DID) from the public network. A typical application of these trunks is to map incoming digits onto target line appearances within the Norstar system. DID trunks can operate only as auto-answer trunks.

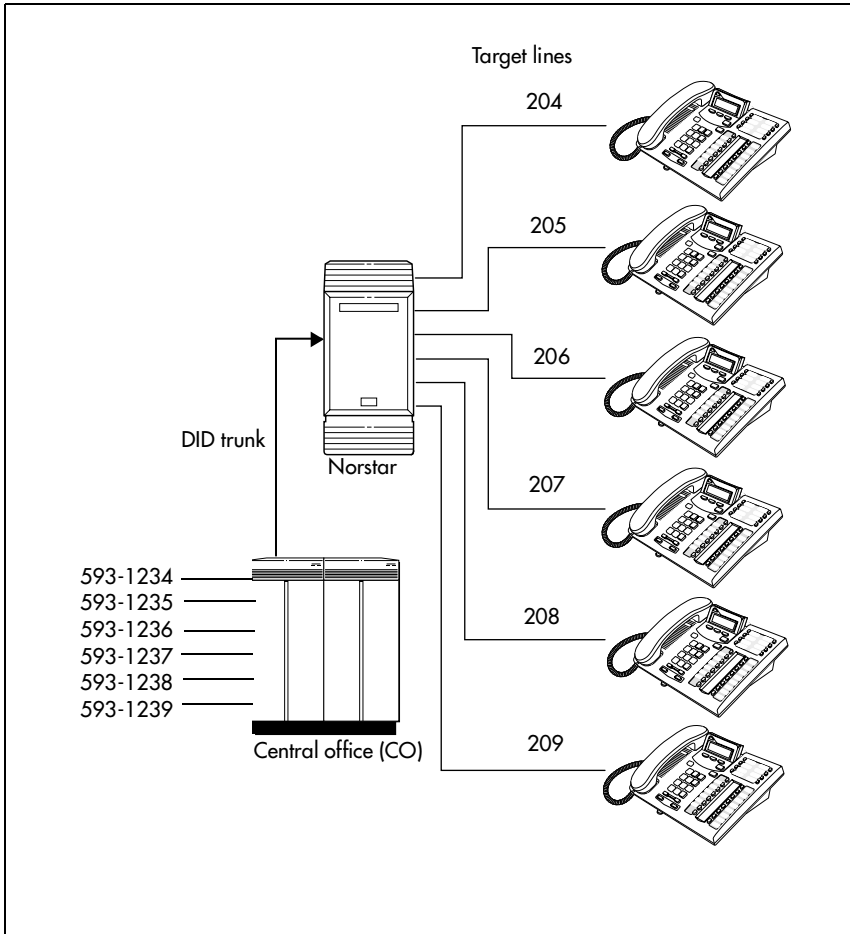

When a call comes in on a DID trunk, the Norstar system interprets the incoming digits in one of the following ways.

- If the digits map onto a target line, the call is routed to all telephones with an appearance of that target line.
- If the digits map onto the DISA DN, the caller hears stuttered dial tone. They must enter a six-digit Class of Service (COS) password from a DTMF telephone to hear system dial tone.

They can then enter a:

- target line number
- line pool access code
- remote feature code
- If the digits map onto the Auto DN, the caller hears system dial tone. They can then enter:
 - a target line number
 - the DISA DN, which will prompt for a Class of Service password
 - a line pool access code
 - a destination code
 - a remote feature code from a DTMF telephone



Tips - *Each DID Trunk Cartridge can provide four DID trunks. Each DID Trunk Cartridge also has four DTMF receivers dedicated to those trunks. A DTI can provide up to 24 DID trunks.*

You cannot configure a DID trunk as the prime line for a Norstar telephone or a Business Series Terminal.

The capabilities available to a remote caller are determined by the remote filters and remote package assigned to a line, or by the set restrictions, line restrictions and remote package assigned to the Class of Service password.

Analog loop start trunks

Loop start trunks give you incoming and outgoing access to the public network. Loop start trunks can be configured as manual-answer or auto-answer. The answer mode determines how the system handles incoming calls.

When a call comes in on a manual-answer loop start trunk, it alerts at all telephones with that line appearance.

When a call comes in on an auto-answer loop start trunk that is configured to answer with direct inward system access (DISA), the caller hears a stuttered dial tone. They must enter a six-digit Class of Service (COS) password from a DTMF telephone to access system dial tone.

Once the caller has system dial tone, they can then enter:

- a target line number
- a line pool access code
- a remote feature code.

By default, auto answer loop start trunks are configured to answer with DISA, and are used to provide controlled access to Norstar system resources.

When a call comes in on an auto-answer loop start trunk that is not configured to answer with DISA, the caller hears system dial tone.

They can then enter:

- a target line number
- the DISA DN, which will prompt for a Class of Service password
- a line pool access code
- a remote feature code from a DTMF telephone

To place an outgoing call, a loop start line can be selected by:

- pressing a line button on the telephone
- dialing a line pool access code
- pressing a memory button that has been programmed with a line pool access code

Configuration tips

- Loop start signaling is supported by Loop Start Trunk Cartridges, Call Information (CI) Trunk Cartridges and Digital Trunk Interfaces (DTI). Each Loop Start Trunk Cartridge or CI Trunk Cartridge can provide four loop start trunks. A DTI can provide up to 24 loop start trunks. If you wish to configure your loop start trunks as auto-answer, the trunks must have disconnect supervision.
- For Loop Start or CI Trunk Cartridges installed in a Trunk Module, you will also need one E&M/DISA Trunk Cartridge for every two loop start trunks that you configure as auto-answer. The E&M/DISA Trunk Cartridge provides two DTMF receivers to receive the incoming digits from the central office. An auto-answer loop start trunk can give you the same kind of direct inward dialing function as a DID trunk.
- If your system includes both loop start trunks and DID trunks, you would typically use loop start trunks for outgoing calls and DID trunks for incoming calls.
- You may configure a loop start trunk as the prime line for a Norstar telephone or a Business Series Terminal.
- The capabilities available to a remote caller are determined by the remote filters and remote package assigned to a line, or by the set restrictions, line restrictions, and remote package assigned to the Class of Service password.

- Two loopstart trunk cartridges are compatible with Modular ICS 6.0. The NT5B40GA-93 can be installed in trunk module (TM) slots only. The NT7B75GA-93 can be installed in either core slots three or four, or TM slots one, two or three.

Analog E&M trunks

An Analog E&M trunk gives you incoming and outgoing access to other systems in a private network. E&M trunks can be configured as manual-answer or auto-answer. The answer mode determines how the system handles incoming calls.

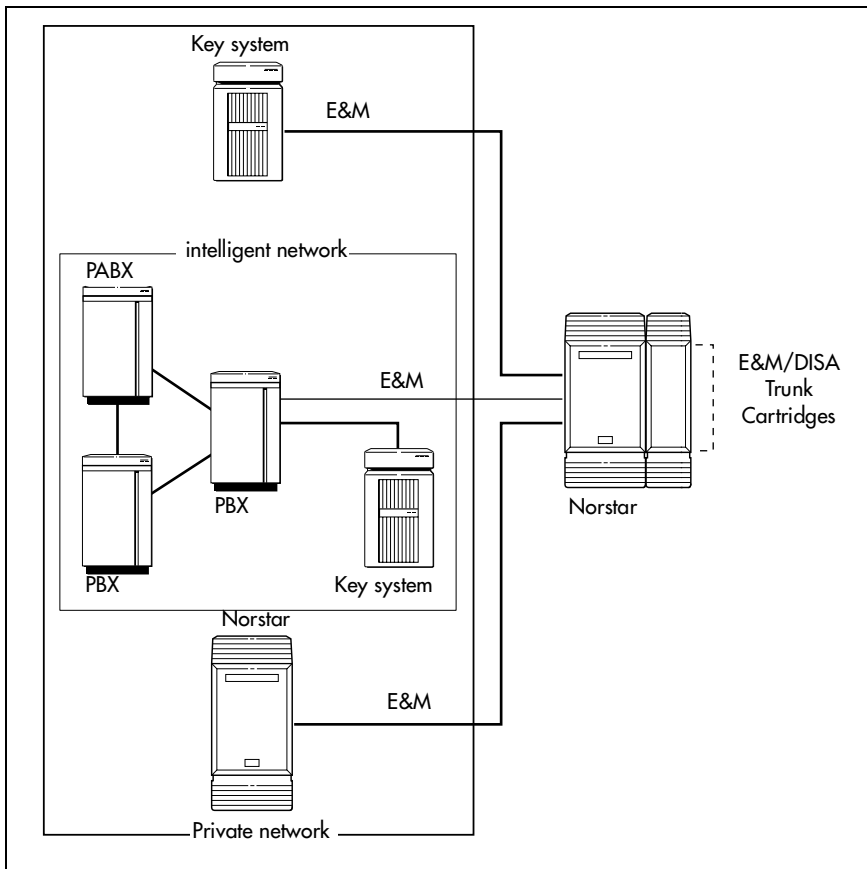

By default, auto-answer E&M trunks are answered by the system with direct inward system access (DISA), and are used to provide controlled access to Norstar system resources.

When a call comes in on a manual-answer E&M trunk, it alerts at all telephones with that line appearance.

When a call comes in on an auto-answer E&M trunk that is configured to answer with DISA, the caller hears stuttered dial tone. They must enter a six-digit COS password from a DTMF telephone to hear system dial tone.

They can then enter a:

- target line number
- line pool access code
- remote feature code

When a call comes in on an auto-answer E&M trunk that is not configured to answer with DISA, the caller hears system dial tone. At that point they can then enter one of the following:

- a target line number
- the DISA DN, which will prompt for a COS password
- a line pool access code
- a remote feature code from a DTMF telephone

To place an outgoing call, an E&M trunk can be selected by one of the following:

- pressing a line button on the telephone
- dialing a line pool access code
- pressing a memory button that has been programmed with a line pool access code.

BRI trunks

BRI trunks give you incoming and outgoing access to an ISDN network. Like loop start trunks, they can be configured as manual-answer or auto-answer. See *Ans mode* on page 341.

BRI trunks provide a fast, accurate, and reliable means of sending and receiving data, images, text, and voice information. Using BRI lines allows for faster transmission speeds and the addition of a variety of powerful business applications, including remote LAN access, video conferencing, file transfer and Internet access.

For more information see *Welcome to ISDN* on page 37.

Note Profile 2: European BRI trunks can be either EURO or SL-1.

PRI trunks

PRI trunks are used for incoming and outgoing calls over an ISDN network. PRI trunks are automatically set to auto-answer.

Incoming calls are routed to system telephones through assigned target lines. Outgoing calls are made using the intercom key, which connects to a line pool, or by entering a destination code, which defines a route for the call.

PRI SI-1 lines also can provide MCDN network functionality over a private network between other Norstar systems, Meridian 1 systems, or Business Communications Systems, if the appropriate keycode has been installed. Private networking is described in *Networking with Norstar* on page 91.

Target lines

A target line is a specific communication path that is reached by means of digits received from an incoming trunk. Target lines are used to answer incoming calls but cannot be used to make outgoing calls.

You can program auto-answer trunks to map to target lines to provide for attendant bypass, which allows the call to go directly to a department or individual, and line concentration, where one trunk can map onto several target lines.

No target lines are assigned to sets, except if the DID template has been applied to the system.

Target lines are referred to by line numbers 157-348 or 157-284, in the same way as physical lines.



Privacy issue

You can set a target line to Private (default is Public), however, such features as Call Pickup can still answer these lines at remote telephones.

Remote system access

The remote access feature allows callers elsewhere on the private or the public network to access a Norstar system by dialing directly without going through an attendant. Once in the system, the remote user can use some of the system resources. The remote access must be enabled in programming before callers can use it.

Norstar systems support remote system access on the following trunk types which may require the remote caller to enter a COS password for direct inward system access (DISA):

- auto-answer loop start trunks
- auto-answer E&M trunks
- DID trunks, by means of the DISA DN
- PRI trunks, by means of the DISA DN

The system resources, such as dialing capabilities, line pool access and feature access, that a remote user may access depends on the Class of Service (COS) assigned to the user. See *Class of Service* on page 85, *COS pswds* on page 382 and the *Modular ICS 6.0 System Coordinator Guide* for more details.

Use system features during a remote call

To use features on a Norstar system during a remote call-in, press **[*]**, followed by the feature code. Even if you are calling from another Norstar system, press **[*]** instead of **[☎]**.

Remote access on loop start and E&M trunks

Loop start trunks provide remote access to Norstar from the public network. E&M trunks provide remote access from a private network. Each must be configured to be auto-answer to provide remote system access.

A loop start trunk **must** have disconnect supervision if it is to operate in auto-answer mode. E&M trunks always operate in disconnect supervised mode.

When a caller dials into the system on a line that has auto-answer, the system answers with system dial tone and no COS password is required. In this case, control over the system capabilities available to the caller is provided only by the restriction filters assigned to the line.

When a caller dials in on a line that has auto-answer with DISA, the system answers with stuttered dial tone. This is the prompt to enter a COS password. The password used by the caller determines which system capabilities are available to the caller.

Remote access on a private network

Nodes on the private network deliver the last dialed digits to the destination Norstar node, for interpretation by the destination Norstar node. The destination Norstar node either matches the digits to a target line or interprets the digits as a remote feature request. The call is either routed to the specified target line, or the remote feature is activated.

By default, E&M trunks are set to answer with DISA. For auto-answer E&M trunks connected to a private network, change the default so that the trunks are **not** answered with DISA. If an auto-answer E&M trunk is configured to answer with DISA, the system tries to interpret any received digits as a COS password.

The DISA DN and the Auto DN allow auto-answer private network and DID calls, in the same way that calls on auto-answer loop start and auto-answer E&M trunks can be answered, with or without DISA. These DNs are described in `System Programming` under `Access codes`.

Remote access on Direct Inward Dial (DID) trunks

Remote system access on DID trunks is similar to that of E&M trunks connected to a private network.

The main differences are:

- a remote caller is on the public network dialing standard local or long-distance telephone numbers
- the digits received are delivered by the central office
- DISA cannot be administered to a DID trunk

As with a private network, the dialed digits may be programmed to match those of a specific target line DN, the DISA DN or the Auto DN.

Remote access on PRI trunks

Remote system access on PRI trunks is similar to that of E&M trunks connected to a private network.

The main differences are:

- a remote caller is on the public network dialing standard local or long-distance telephone numbers
- the digits received are delivered by the central office
- answer with DISA cannot be administered to a PRI trunk since PRI trunks are set to autoanswer.

As with a private network, the dialed digits may be programmed to match those of a specific target line DN, the DISA DN, or the Auto DN.

Controlling system access

Modular ICS programming provides several ways of protecting your Norstar system from unauthorized access or use. These features are used in combination to provide control both to users and to lines.

Class of Service

Class of Service (COS) refers to the capabilities that Norstar provides to users who access the system from the public or private network. A password defines which set of capabilities the user is to have access to.

The COS includes:

- filters that restrict dialing on the line
- an access package defines the set of line pools that may be accessed and whether or not the user has access to the paging feature

The COS that is applied to an incoming remote access call is determined by:

- the filters that you apply to the incoming trunk
- the Class of Service password that the caller used to gain access to the Norstar system

In cases where DISA is not automatically applied to incoming calls, the remote caller can change the COS by dialing the DISA DN and entering a COS password.

To program COS passwords, see *Passwords* on page 382 and the *Modular ICS 6.0 System Coordinator Guide*.

Restriction filters

Restriction filters can be used to restrict the numbers that may be dialed on any external line within your Norstar system. Up to 100 restriction filters can be created for the system.

A restriction filter consists of up to 48 restrictions with associated overrides.

To restrict dialing within the system, you can apply filters to:

- outgoing external lines (as line restrictions)
- telephones (as set restrictions)
- external lines on specific telephones (as line/set restrictions)

Restriction filters can also be specified in **Restriction Service**, for times when the system is operating according to a Schedule. See *Services* on page 353 for more details.

Dialed digits must pass both the line restrictions and the set restrictions. The line/set restriction overrides the line restriction and set restriction. Refer to the following diagrams.

Line restrictions

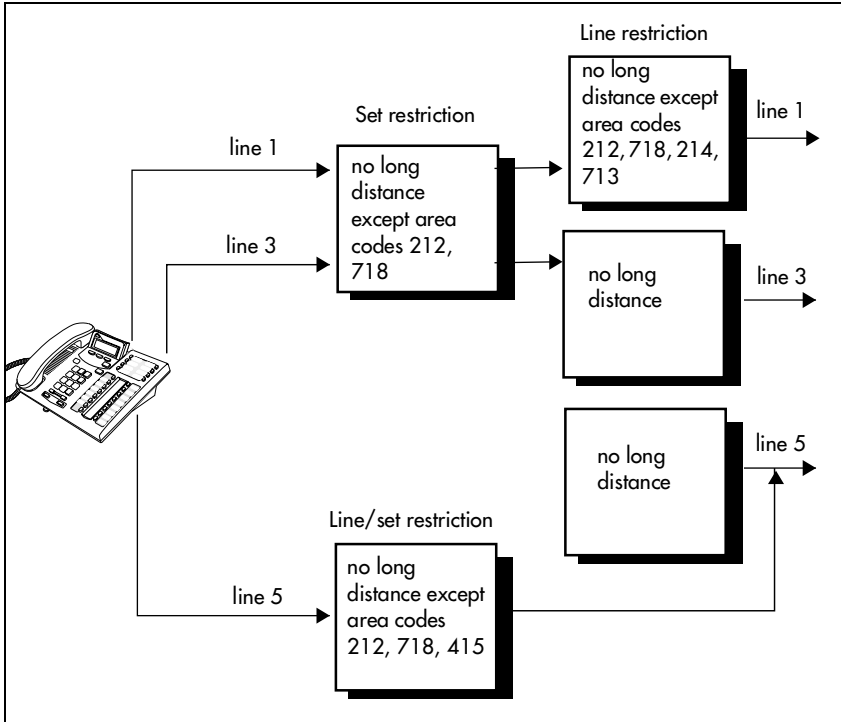

In the previous diagram, a caller using line 1 could only dial long-distance numbers to area codes 212 and 718. A caller using line 3 could not dial any long-distance numbers. A caller using line 5 could dial long-distance numbers to area codes 212, 718, and 415.

Remote caller restrictions

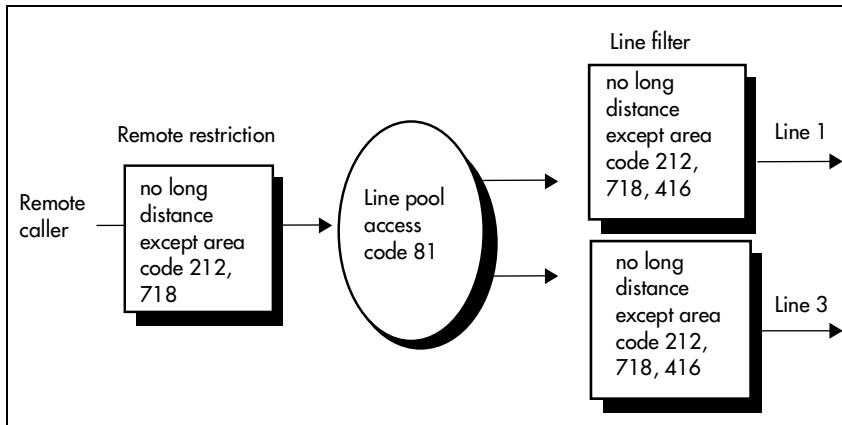

Tips - *Set restrictions have no effect on numbers dialed on an E&M trunk.*

To restrict dialing outside the system, once a caller gains remote access, you can apply restriction filters to incoming external lines, as remote restrictions.

In this case, dialed digits must pass both the remote restriction and the line restriction. A remote caller can override these filters by dialing the DISA DN and entering a COS password.

For restriction filter programming instructions, see *Restrictions* on page 322 and the *Modular ICS 6.0 System Coordinator Guide*.

Direct inward system access (DISA)

To control access from the public or private network, you can configure auto-answer trunks to answer with DISA. Remote callers hear a stuttered dial tone and must then enter a COS password. The password they enter determines what access they are allowed in the system.

Auto-answer loop start and E&M trunks are configured to answer with DISA by default. For DISA programming instructions, see *Ans with DISA* on page 342.



Tips - *You must have one E&M/DISA Trunk Cartridge to provide DTMF receivers for every two auto-answer loop start trunks on Loop Start or CI Trunk Cartridges.*

DID trunks cannot be configured to answer with DISA. If you want incoming DID calls to be answered with DISA, configure the system with a DISA DN. Incoming DID calls that map onto the DISA DN are then routed to a line that has DISA.

In addition to public network connections, Norstar Modular ICS can be integrated into an existing private network, or to other Norstar or Meridian 1 systems to form a corporate telecommunications network.

Networking with Norstar

There are a number of ways you can network Norstar systems together, or network Norstar systems with other Nortel systems into private networks. What types of lines you use to perform the networking will determine the type of services that can be shared between systems.

Keep in mind, that each node (Norstar system) is considered an external system by every other node within the network, even though, to the users, it appears to be all one system. This affects how you configure call transfer and call out features on each system. On the home node, all features are configured as local numbers. On all other nodes, all features are configured with external numbers.

As well, each node must have a unique identifying code. What this code will be, and how it is configured for the user, depends on what type of trunks and dialing rules you choose to use.

This section describes various configurations of private networks. The general settings that are required to set up the home node for each system is provided to give you a sense of what is required for each type of network.

The common goal is to provide the user with the sense that the network is one large system that provides common access to colleagues in other buildings, cities, or countries. In some systems they may need to enter a destination code before the local number to route the call to the correct system. In other systems, using a common dialing plan allows users to dial colleagues at any location simply by entering the same number of digits they would use to dial a colleague at the next desk.

Tie-line networking

Norstar uses enhanced trunking to join other Norstar or customer equipment in a private network. This allows authorized users access to tie lines, central office lines, and Norstar features from outside the Norstar system.

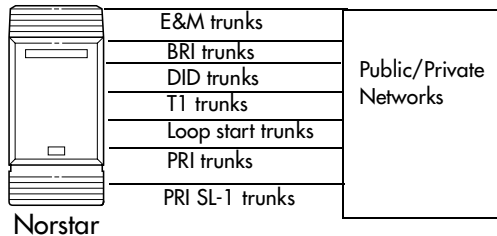

Callers using the Norstar Modular ICS system can:

- call directly to a specific Norstar telephone
- select an outgoing tie line to access a private network
- select an outgoing tie line to access features that are available on the private network
- select an outgoing central office line to access the public network
- use all of the Norstar features

Callers in the public network can:

- call directly to one or more Norstar telephones
- call into the Norstar system and select an outgoing tie line to access a private network
- call into the Norstar system and select an outgoing central office line to access the public network

- call into the Norstar system and use remote features

Callers in the private network can:

- call directly to one or more Norstar telephones
- call into the Norstar system and select an outgoing tie line to access other nodes in a private network
- call into the Norstar system and select an outgoing central office line to access the public network
- call into the Norstar system and use remote features

Norstar behind a PBX

Norstar Modular ICS can be used behind a PBX. In order to support this application, the trunk lines must be set up not to exceed 8 dB total loop loss from the serving central office to the connection point at the Norstar ICS.

Dialing plans

Dialing plans allow users to enter consistent dialing information to call other systems, or out to a public network through another system. The type of network determines what kind of dialing scheme is required.

The Norstar system has routing features that allow you to set up a transparent dialing plan with other systems in a public or private network. In a private network, you can choose to use either a uniform dialing plan (UDP) or a coordinated dialing plan (CDP) to determine how the system recognizes private network dialing strings.

A networked system uses the Public DN length to determine the number of digits that must be collected before the call is dialed outside each node on the system. Calls routed over private networks using CDP also use the public DNs in concert with a destination code that determines the routing of dialed DN. With CDP, the node identifier is included in the dialed DN string and is unique to each node.

Calls routed over private networks using UDP require a private DN length, since each node requires an identification code in the dialing string, which makes the DN length different than for a public-routed call.

If you create a network-wide dialing plan using CDP:

- all telephone DNs across the network need to be the same length (Public DN length)
- the first digit of the DN must be unique to each system, i.e. node A has DNs 2222 to 2999, node B has DNs 3222 to 3999, and so on.

- you indicate that you are using a coordinated dialing plan (System Programming/Dialing Plan/Private network)
- you create access codes that are routed out on auto-answer lines connected to the other sites (Access Codes and Call Routing)
- a telephone can be reached using the access code and the telephone number, regardless of where the call originates in the network

If you are networked using UDP:

- you indicate a private DN length, which is the number of digits required to access sets in the system (System Programming/Dialing Plan/Private network)
- each system has a unique location code (System Programming/Dialing Plan/Private network)
- you indicate that you are using a UDP dialing plan (System Programming/Dialing Plan/Private network)
- you set up private access codes (Access codes/Private access codes)
- a telephone in another node is accessed using the access codes, the location code, and the telephone DN.

Any programming for routing and access codes should be carefully planned using the tables supplied with the *Programming Record*. The settings for routing and destination codes are fully explained in *Services* on page 353.

Note: Network access codes must not conflict with access codes used for other purposes.

Dialing plan using public lines



For example imagine that you have a system in a network of three offices such as New York, Toronto, and Santa Clara.

If there is no routing, callers would have to dial this way:

- A Norstar user in New York would have to select a line pool and dial a number such as 1-416-555-3227 to reach telephone 3227 in Toronto (416).

If there is routing:

- you could create a destination code of 3, and create a route that uses the proper line pool and DialOut. In this case, the user simply dials 3227, the receiving telephone DN being 227.

In the DialOut, P stands for pause, a host system signalling option. Press    to insert a 1.5-second pause in the dialing string. See the *Modular ICS 6.0 System Coordinator Guide* for information about other signals.

Destination code numbering in a network

Because the system checks the initial digits of a call against the routing tables, each type of internal or external call must begin with a unique pattern of digits. The following table gives a sample plan for how initial digits are assigned in a network of systems with three-digit DNs.

Leading Digits	Use
0	Network Direct Dial
221-253 (default)	Intercom calls (DNs)
4	Coordinated Dialing Plan
5	Unused
6	Unused
8	Call Park Prefix
9	All PSTN Calls

In the table, 4 is used as the initial digit for the Coordinated Dialing Plan (CDP), but 5 or 6 could also be used for this purpose.

For PRI you need to define a route with a routing code, then assign that code to the telephone.

Dialing plan using E&M lines

By properly planning and programming routing tables and destination codes, an installer can create a dialing plan where:

- E&M lines between Norstar systems are available to other systems in the network

The following figure and programming chart shows how to configure a transparent dialing plan for a network of three Norstars over E&M lines.

- Each system must be running the same version of MICS 6.0 or MICS-XC 6.0 software.
- Each system must be equipped with target lines and a Trunk Module with an E&M/DISA Trunk cartridge or an ICS with a DTI with at least one E&M line.

Routing by destination codes over E&M lines

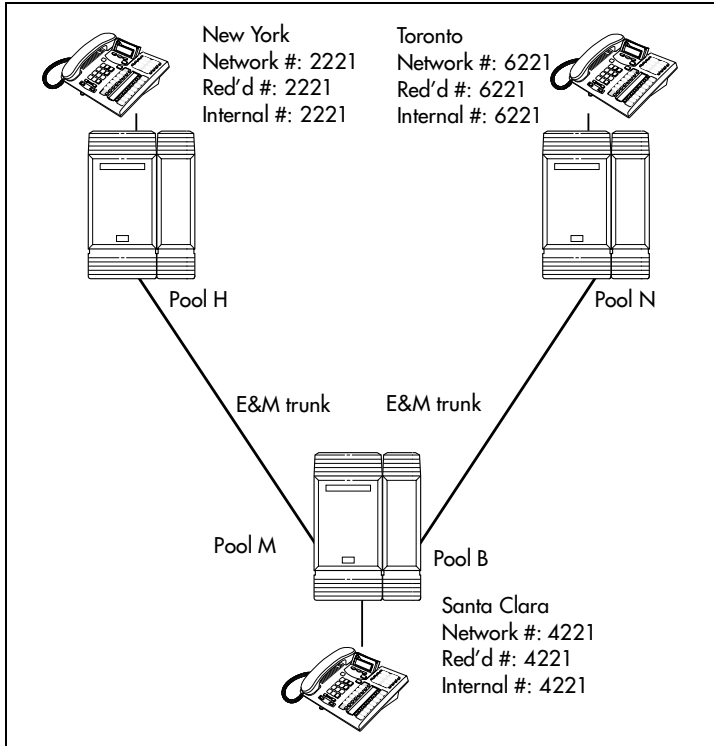

Heading	Parameter	Setting
New York:		
Trk/Line Data	Line 049	E&M
	Ans Mode	Auto
	Line type	Pool H
	Line 245	Target line
	Rec'd #	2221
Line Access	DN 2221	L245: Ring only
	Line pool access	Line pool H

Heading	Parameter	Setting
To Santa Clara:		
Routing service	Route	001
	Use	Pool H
	DialOut	None
	DestCode	4
	Normal rte	001
	Absorb	0
To Toronto:		
Routing service	DestCode	6
	Absorb	0
	Normal rte	001
Santa Clara:		
Trk/Line Data	Line 050	E&M
	Ans Mode	Auto
	Line type	Pool M
Trk/Line Data	Line 049	E&M
	Ans Mode	Auto
	Line type	Pool B
	Line 250	Target line
	Rec'd #	4221
Line Access	DN 4221	L250: Ring only
	Line pool access	Line pool B Line pool M
To New York:		
Routing service	Route	001
	Use	Pool M
	DialOut	None
	DestCode	2
	Absorb	0

Heading	Parameter	Setting
	Normal rte	001
To Toronto:		
Routing service	Route	002
	Use	Pool B
	DialOut	None
	DestCode	6
	Absorb	0
	Normal rte	002
Remote access	Rem access pkgs	01
	Line pool access	Pool M: ON
	Rem access pkgs	02
	Line pool access	Pool B: ON
	Line abilities	049
	Remote pkg	01
	Line abilities	050
	Remote pkg	02
Toronto:		
Trk/Line Data	Line 053	E&M
	Ans Mode	Auto
	Line type	Pool N
	Line 260	Target line
	Rec'd #	6221
Line Access	DN 6221	L260: Ring only
	Line pool access	Line pool N
To New York:		
Routing service	Route	001
	Use	Pool N
	DialOut	None
	DestCode	4

Heading	Parameter	Setting
	Absorb	0
	Normal rte	001
To Santa Clara:		
Routing service	DestCode	2
	Absorb	0
	Normal rte	001

In the above example:

If a user in New York calls Toronto within the network, they dial 6221. The local Norstar checks the number against the routing tables and routes the call according to the destination code 6, which places the call using Route 001.

There is no DialOut change to the number from New York, so the call appears on the auto answer line on the Norstar in Santa Clara as 6-221.

Because 6 is also a destination code on the Santa Clara system, another call is placed using route 002 from Santa Clara. This call arrives at the Toronto system, where the digits 6-221 are interpreted as a target line received number. The call will now alert at telephone 6221 in Toronto.

Dialing plans with shared line pools

Using routes and destination codes is a powerful and efficient way to create a transparent dialing plan. Line pools offer an alternate method of creating a dialing plan or supplementing the routing and destination codes. This is the type of dialing plan you would create for tandem networking between two or more Norstar systems.

If the Norstar systems are close to each other geographically, you can conserve resources by not duplicating access. For example, system A, B, and C are all within the same area code. System A has a line pool to Santa Clara, System B has a line pool to Montreal, and system C has a line pool to Miami. A Norstar user in system A can reach Miami by calling system C and using that line pool to Miami.

To simplify access between Norstar systems, all line pools that go to the same destination should have the same line pool access code. For example, system A and system B both have a line pool to Ottawa. You can configure both systems with the same line pool access code for the Ottawa line pool.

A dialing plan similar to the one in the following figure allows you to create a company directory that uses line pool access codes and unique DNs of a uniform length.

Networking with shared line pools

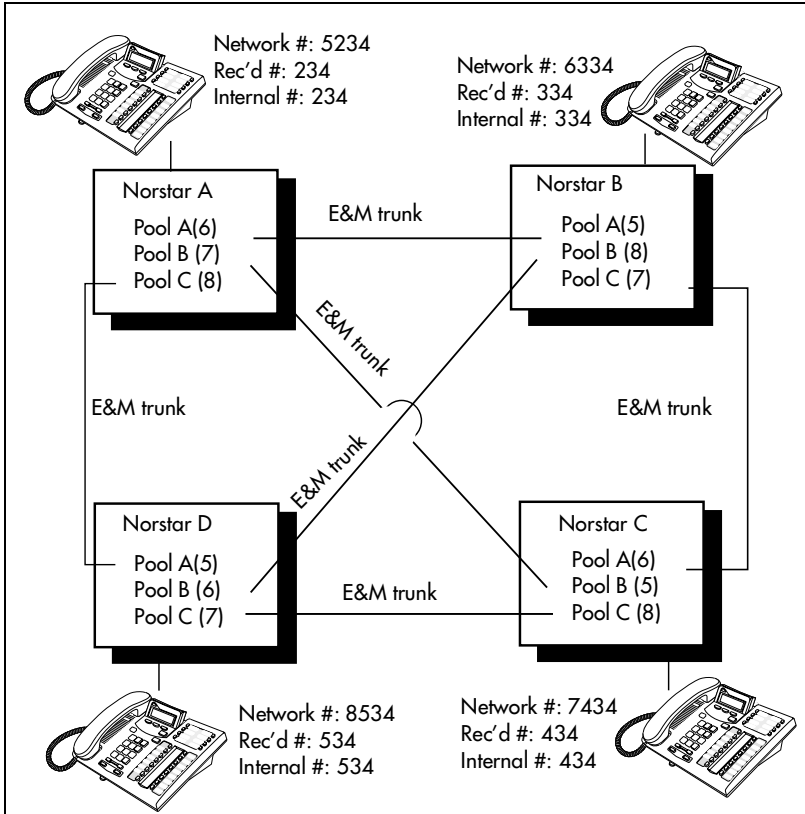

For instance, the person on system A at telephone 234 can press an Intercom button and dial 7434.

This means that telephone 234 has dialed the line pool access code of the trunk to system C, and will receive the dial tone of system C. The digits 434 then map to the Received number 434, and ring telephone 434 with an appearance of the associated target line.



Tips - Network calls that use routes are subject to any restriction filters that are in effect.



If the telephone used to make a network call has an appearance of a line used by the route, the call will move from the intercom button to the line button.

The telephone used to make a network call must have access to the line pool used by the route.

Network calls are external calls, even though they are dialed as if they were internal calls. Only the features and capabilities available to external calls can be used.

When programming a button to dial a Network number automatically (autodial), network calls must be treated as external numbers, even though they resemble internal telephone numbers (DNs).

Routes generally define the path between your Norstar switch and another switch in your network, not other individual telephones on that switch.

Call-by-Call Services Example

This example highlights the use of PRI Call-by-Call Services.

It shows two offices of a company. One office is in New York, the other is in Toronto. Each office is equipped with a Norstar system and a PRI line. Each office has to handle incoming and outgoing calls to the public network. In addition, employees at each office often have to call colleagues in the other office. To reduce long-distance costs, and to allow for a coordinated dialing plan between the offices, private (tie) lines are used to handle inter-office traffic.

Call-by-Call routing

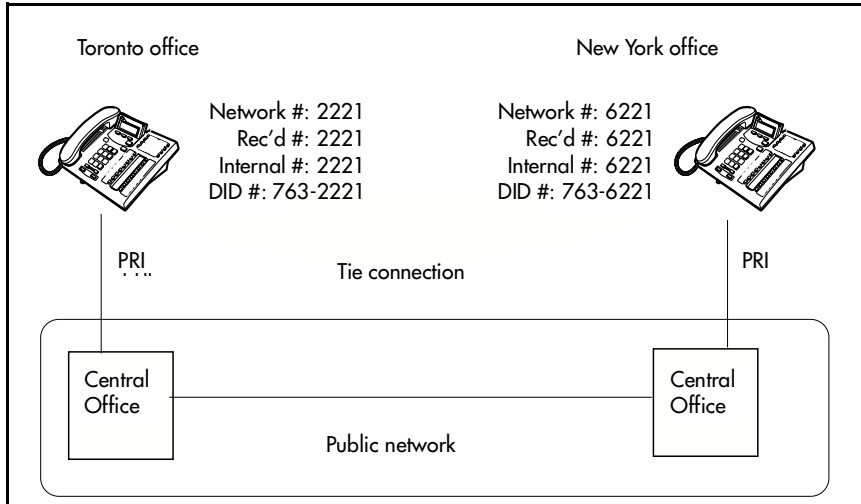

If call-by-call services were *not* used, each Norstar system might have to be equipped with the following trunks:

- 12 DID lines needed to handle peak incoming call traffic.
- eight Tie (E&M) lines needed to handle inter-office calls.
- eight lines needed to handle outgoing public calls

The total required is 28 lines. If the Norstar systems were using T1 trunks, then two T1 spans would be required at each office. Note that the total of 28 lines represents the worst case value for line usage. In reality, the total number of lines in use at any one time will generally be less than 28. For example, during periods of peak incoming call traffic, the demand for outgoing lines will be low.

With PRI call-by-call services, it is not necessary to configure a fixed allocation of trunks. Each of the 23 lines on the PRI can be used for DID, Tie, or outgoing public calls. This consolidation means that it may be possible for each office to use a single PRI span, rather than two T1 spans.

With PRI call-by-call services, the only limitation is that there are no more than 23 calls in progress at any one time.

The dialing plan at each Norstar site is configured to determine the call type based on the digits dialed by the user. If a user in Toronto wishes to dial a colleague in New York, they dial the four-digit private DN (such as 6221). The dialing plan recognizes this as a private network DN, and routes the call using Tie service with a private numbering plan.

Incoming Tie calls are routed to sets based on the digits received by the network, which in this case will be the four-digit private DN.

If a user in either location wishes to dial an external number, they dial 9, followed by the number (such as 9-555-1212). The dialing plan recognizes this as a public DN, and routes the call using Public service.

Incoming DID calls will be routed to sets based on the trailing portion of the digits received by the network. For example, if a public network user dials an employee in the Toronto office, the network will deliver digits 4167632221. Norstar will route the call using the last four digits, 2221.

Norstar Configuration

Heading	Parameter	Setting
Toronto:		
Hardware	Card 1	PRI
	Protocol	NI-2
Trk/Line Data	Line 245	Target line
	Rec'd #	2221
Line Access	DN 2221	L245:Ring only
	Line pool access	Line pool PRI-A

Heading	Parameter	Setting
To New York:		
Routing Service	Route	001
	DialOut	No numbr
	Use	Pool PRI-A
	Srvctype	Tie
	ServiceID	1
	DN type	Private
	DestCode	6
	Normal rte	001
Absorb	0	
To Public Network:		
Routing Service	Route	002
	DialOut	No numbr
	Use	Pool PRI-A
	DN type	Public
	DestCode	9
	Normal rte	002
	Absorb	ALL
New York:		
Hardware	Card 1	PRI
	Protocol	NI-2
Trk/Line Data	Line 245	Target line
	Rec'd #	6221
Line Access	DN 6221	L245:Ring only
	Line pool access	Line pool PRI-A
To Toronto:		
Routing Service	Route	001
	DialOut	No numbr
	Use	Pool PRI-A

Heading	Parameter	Setting
	SvcType	Tie
	ServiceID	1
	DN type	Private
	DestCode	2
	Normal rte	001
	Absorb	0
To Public Network:		
Routing Service	Route	002
	DialOut	No numbr
	Use	Pool PRI-A
	DN type	Public
	DestCode	9
	Normal rte	002
	Absorb	ALL

PRI dialing plan example for two-way DID

The following list shows the steps involved in configuring a dialing plan for two-way DID which uses a Public service. In this example the user dials the prefix 8 to place a call over a PRI line.

Note: Call-by-call is not needed to have two-way DID.

- in **Hardware** programming, configure the DTI card (PRI) to use a **Public** protocol
- for incoming calls you need to program target lines to match the DID digit that is being received on the PRI interface
- set **Dial Out** to None
- select PRI-A as the **line pool**

- set `SrvcType` to Public
- in `Services` programming access `Routing Service` to enter a `Destination Code` (8 in this example)
- set the `Absorb Length` to All
- the telephone that you are dialing out from must have access to the PRI Pool (programmed in `Terminals/Sets`)
- define `rec'd digits` for target lines
- define limits for incoming and outgoing public calls. Refer to *Programming Call by Call Limits* on page 437

Static DID and two-way DID

When configuring static DID with two-way service, the channels programmed as DID at the CO must be the lowest B-channels on the PRI. On your Norstar system, the `BchanSeq` mode must be set to `descending`. In this configuration, all calls on the PRI must be Public service.

For example, channels 1 to 4 are configured as DID at the CO. The CO uses ascending mode for B-channel selection, and the ICS uses descending mode.

Private networking using PRI SL-1

You can use PRI SL-1 lines to tandem a number of Norstar units into a private network. This creates a Private Network Tandem Calling (PNTC) configuration. Refer to *Private Network Tandem calling* on page 112.

You can also use PRI SL-1 lines to link one or more Norstar systems to a Meridian 1 system, or to create a network that includes one or more Business Communications Manager systems. This creates an Advanced Private Network (APN) where the MCDN protocol can be used to provide network control features that allow network calls to be delivered and transferred with optimum efficiency. If you also use a central voice mail system or central Auto Attendant system, MCDN provides system-wide Auto Attendant features and line redirection. Refer to *Advanced Private Networking* on page 121.



Tip - *For Modular ICS 6.0 you require both a PRI software key and an MCDN software key to perform SL-1 networking.*

All Norstar systems in the network also must be running MICS 6.0 or MICS-XC 6.0 or greater software.

SL-1 networking features

- common dialing plan using a Uniform Dialing Plan (UDP), or a Coordinated Dialing Plan (CDP)
Note: If Norstar voice mail or Auto Attendant is used as the centralized voice mail system, CDP must be used for the network.
- PRI networks can be used for voice, data, and video calls
- no usage costs when placing remote calls over private networks

- caller information appears on both the caller telephone and the called telephone, regardless of the number of redirections
- PSTN lines connected to one of the nodes in a network can provide local public service, at local rates, to all nodes in the network, regardless of location

Features specific to Advanced Private Network

- centralized voice mail provides call waiting indications on the receiving telephone
- centralized voice mail provides common messages, call-forwarding and transfer options to all networks. If you are using the Meridian attendant system, the attendant console on the Meridian system can use system-wide parking (camp-on) and break-in features.
- if you have trunk route optimization (TRO) on, the system optimizes call routing of redirected calls over the private network
- the Meridian PBX can handle both UDP and CDP, thus providing more flexibility and less reprogramming when networking existing systems. The Norstar Voice mail system requires a CDP dialing plan when it is being used for central call handling.
- Trunk Anti-tromboning (TAT) provides network rerouting that provides more efficient routing of calls to prevent unnecessary tandeming and tromboning of trunks.
- ISDN Call Connection Limitation (ICCL) piggybacks on the call initiation request and acts as a check at transit PBX points to prevent misconfigured routes or calls with errors from blocking channels.

- NCRI count allows a call to be forwarded in the network up to five times before the system releases the call as undelivered. However if TAT or TRO occur, the counter gets reset, as well. This counter is hard-coded.
- Profile 2: ETSI private networks provide line redirection.

Private Network Tandem calling

Tandem networking is a chained network established between two or more MICS systems. All the systems are connected via PRI SL-1 lines.

In the network example shown below, nodes A, B, and E are in one location, Nodes C, D, and F are in a second location. The two systems are tied together between nodes A and C.

Nodes A and C are also connected to the local public network.

This configuration allows both local network users and remote users on the public network to access the remote PSTNs through the private lines, thus avoiding public call charges.

All nodes have unique three-digit private identification codes as well as public network codes. Routes and destination tables are configured on all systems to correctly route dialed numbers to other nodes. DNs do not necessarily have to be unique, but they must be the same length on all systems.

Tandem network

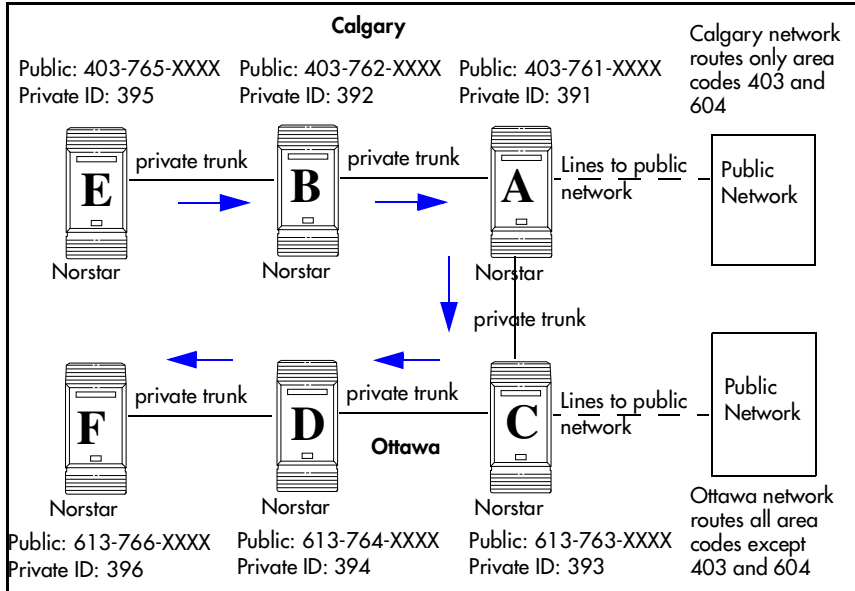

Calls originating from the public network

Received	Destination	Description
Node A	Node A	User in Calgary dials 761-xxxx number Incoming interface: Public DN type: Public
		Node A receives the call and identifies it as terminating locally. Uses target line to route call. Destination: Local (target line)

Received	Destination	Description
Node A	Node B	User in Calgary dials a 762-xxxx number DN type: Public
		Node A receives it and identifies it as being for node B. Uses private trunk to route it to B. Incoming interface: Public Destination: Remote Node Outgoing interface: Private
		Node B receives the call and identifies it as terminating locally. Uses target line to route call. Incoming interface: Private Destination: Local (target line)
Node A	Node E	User in Calgary dials a 765-xxxx number. DN type: Public
		Node A receives it and identifies it as being for B. Uses private trunk to route call to B. Incoming interface: Public Destination: Remote node Outgoing interface: Private
		Node B receives it and identifies it as being for E. Uses private trunk to route call to E. Incoming interface: Private Destination: Remote node Outgoing interface: Private
		Node E receives the call and identifies it as terminating locally. Uses target line to route call. Incoming interface: Private Destination: Local (target line)

Received	Destination	Description
Node A	Node C	User in Calgary dials a 761-xxxx number which is answered with DISA. Incoming interface: Public DN type: Public Destination: Local (DISA DN)
		User enters a COS password and a private DN for Node C i.e. 6 + 393-xxxx DN type: Private
		Node A receives it and identifies it as being for C. Uses the private trunk to route the call to C. Incoming interface: (DISA user) Destination: Remote node
		Node C receives the call and identifies it as terminating locally. Uses target line to route call. Incoming interface: Private Destination: Local (target line)
Node A	Node D	User in Calgary dials a 761-xxxx number which is answered with DISA. Incoming interface: Public DN type: Public Destination: Local (DISA DN)
		User enters a COS password and a private DN for Node D, i.e. 6 + 394-xxxx DN type: Private
		Node A receives it and identifies it as being for C. Uses the private trunk to route the call to C. Incoming interface: (DISA user) Destination: Remote node
		Node C receives it and identifies it as being the responsibility of D. Uses private trunk to route call to D. Incoming interface: Private Destination: Remote node
		Node D receives the call and identifies it as terminating locally. Uses target line to route call. Incoming interface: Private Destination: Local (target line)

Received	Destination	Description
Node A	Ottawa PSTN	User in Calgary dials a 761-xxxx number which is answered with DISA. User enters a COS password and an Ottawa public network number. Incoming interface: Public DN type: Public Destination: Local (DISA DN)
		Node A receives it and identifies it as being for C. Uses the private trunk to route the call to C. Incoming interface: Local (DISA user) Destination: Remote PSTN
		Node C receives the call and identifies it as a public number and routes it out over the local PSTN. Incoming interface: Private Destination: Local PSTN

Calls originating in the private network

Received	Destination	Description
Node B	Node B	DN is internal, therefore no trunk routing is required. Incoming interface: Intercom DN type: Local Destination: Local
Node A	Ottawa PSTN	User in Node A dials the private network access code for Node C, followed by an Ottawa public number. Incoming interface: Intercom DN type: public Destination: Remote PSTN
		Node C receives the call and identifies it as being for the public network. Node C routes the call over the local public network. Incoming interface: Private DN type: Public Destination: Local PSTN

Received	Destination	Description
Node B	Calgary PSTN	User on Node B dials a public DN.
		Node B recognizes it as being the responsibility of Node A and uses private trunk to route the call to A. Incoming interface: Intercom Destination: Remote node
		Node A receives the call and identifies it as being for the public network. Node A routes the call over the local public network. Incoming interface: Private Destination: Remote PSTN
Node B	Node A	User in Node B dials a private DN for a user on A. DN type: Private
		Node B recognizes it as being for Node A. Uses the private trunk to route the call the call to A. Incoming interface: Intercom Destination: Remote node
		Node B receives the call and identifies it as terminating locally. Uses target line to route call. Incoming interface: Private Destination: Local (target line)
Node B	Node C	User on Node B dials a private DN for a user on C. DN type: Private
		Node B recognizes it as being the responsibility of Node A and routes the call over the private trunk to A. Incoming interface: Intercom Destination: Remote node
		Node A receives it and identifies it as being for C. Uses IP trunk to route call to C. Incoming interface: Private Destination: Remote node
		Node C receives the call and identifies it as terminating locally. Uses target line to route call. Incoming interface: Private Destination: Local (target line)

Received	Destination	Description
Node B	Node D	User on B dials a private DN for node D. DN type: Private
		Node B identifies it as being for node A and uses private trunk to route the call to A. Incoming interface: Intercom Destination: Remote node
		Node A receives it and identifies it as being for C. Uses IP trunk to route call to C. Incoming interface: Private Destination: Remote node
		Node C receives it and identifies it as being for D. Uses the private trunk to route call to D. Incoming interface: Private Destination: Remote node
		Node D receives the call and identifies it as terminating locally. Uses target line to route call. Incoming interface: Private Destination: Local (target line)
Node B	Node F	User on B dials a private DN for node F. DN type: Private
		Node B identifies it as being for node A and uses private trunk to route the call to A. Incoming interface: Intercom Destination: Remote node
		Node A receives it and identifies it as being for C. Uses IP trunk to route call to C. Incoming interface: Intercom Destination: Remote node
		Node C receives it and identifies it as being for D. Uses the private trunk to route call to D. Incoming interface: Intercom Destination: Remote node
continued on next page		

Received	Destination	Description
Node B to Node F (continued)		Node D receives it and identifies it as being for F. Uses the private trunk to route call to F. Incoming interface: Intercom Destination: Remote node
		Node F receives the call and identifies it as terminating locally. Uses target line to route call. Incoming interface: Private Destination: Local (target line)

Routing for tandem networks

In tandem networks each node needs to know how to route calls that do not terminate locally. To do this, you set up routes for each connecting node by defining destination codes for each route.

If the node is also connected to the public network, the usual routing is required for that connection.

The following examples, show the routing tables for Node A and Node C for externally-terminating calls.

Note: The PRI lines are enbloc lines, so all dialed digits are collected before being dialed out.

Node A Destination Code Table, external termination

Route	Absorb length	Destination code (public DNs)
4 (PSTN)	1	91604
3 (Node B)	0	91403762 (Node B)
3 (Node B)	0	91403765 (Node E)
4 (PSTN)	1	9140376* (not internal network)
4 (PSTN)	1	914037* (not internal network)
4 (PSTN)	1	91403* (not internal network)
4 (PSTN)	1	9* (not internal network)
* This wild card represents a digit between 1 and 9.		

Node A Destination Code Table, internal termination

Route	Absorb length	Destination code (private DNs)
3 (Node B)	0	392 (Node B)
3 (Node B)	0	395 (Node E)
5 (Node C)	0	393 (Node C)
5 (Node C)	0	394 (Node D)
5 (Node C)	0	396 (Node F)

Node C Destination Code Table, external termination

Route	Absorb length	Destination code (Public DNs)
3 (Node B)	0	91613764 (Node D)
3 (Node B)	0	91613766 (Node F)
4 (PSTN)	1	9161376* (not internal network)
4 (PSTN)	1	916137* (not internal network)
4 (PSTN)	1	91613* (not internal network)
4 (PSTN)	1	9161* (not internal network)
4 (PSTN)	1	916* (not internal network)
4 (PSTN)	1	91* (not internal network)
4 (PSTN)	1	9 (not internal network)
* This wild card represents a digit between 1 and 9.		

Node C Destination Code Table, internal termination

Route	Absorb length	Destination code (Private DNs)
3 (Node D)	0	394 (Node D)
3 (Node D)	0	396 (Node F)
5 (Node A)	0	391 (Node A)
5 (Node A)	0	392 (Node B)
5 (Node A)	0	395 (Node E)

Advanced Private Networking

There are two ways of setting up dialing plans for an Advanced Private Network (APN).

- The first method uses routing tables to interconnected systems. This type of network may use SL-1 lines, but it does not use the MCDN protocol, even though the MCDN keycode is require to allow the use of PRI SL-1 lines.
- The second method allows you to network among other Norstar systems, Meridian systems, and Business Communications Manager systems using SL-1 lines and the MCDN protocol. This system uses the private dialing plans in the same way as the Private Network Tandem Calling network does. However, if you are using a Norstar to support your central voice mail or call attendant, you must use a CDP dialing plan. The MCDN protocol provides additional features that support the central voice mail/Auto Attendant as well as system call routing.

Networking using routing codes

If you have a simple private network, composed of one central Meridian 1 and two smaller sites with Norstar systems, you can use routing codes to direct calls. The following example shows a Meridian 1, representing the head office, connected to several smaller branch offices.

In this network, only the head office has trunks connected to the public network. The branch offices access the public network via the private connection to the head office. This configuration allows for cost savings by consolidating the public access trunks. Users at all three locations access the public network by dialing 9, followed by the public number.

For example, a user in the west end branch might dial 9-555-1212 (for a local call) or 9-1-613-555-1212 (for a long distance call). These public calls are routed to the Meridian 1 by the Norstar routing table. Routing tables at the Meridian 1 will then select an appropriate public facility for the call.

Private network calls are made by dialing a four-digit private network DN. For example, if a user in the west end branch wishes to call a user in the east end branch within the private network, they dial 6221.

Private networking using routing tables

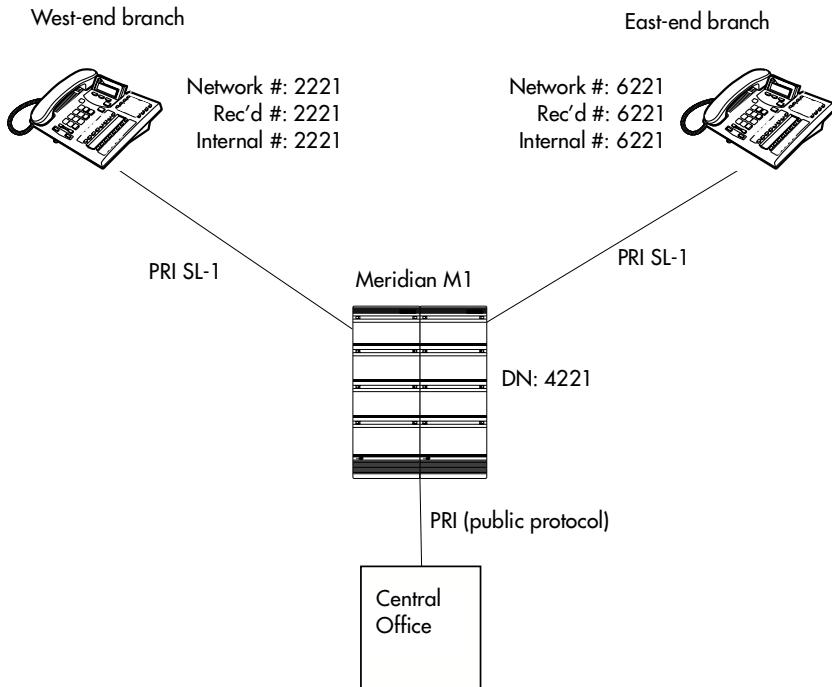

Routing network settings

Heading	Parameter	Setting
West End:		
Hardware	Card 1	PRI

Heading	Parameter	Setting
	Protocol	SL-1
	BchanSeq	Ascend
	ClockSrc	Primary
Trk/Line Data	Line 245	Target line
	Rec'd #	2221
Line Access	DN 2221	L245:Ring only
	Line pool access	Line pool PRI-A
To Head Office:		
Routing Service	Route	001
	DialOut	No numbr
	Use	Pool PRI-A
	DN type	Private
	DestCode	4
	Normal rte	001
	Absorb	0
To East End:		
Routing Service	DestCode	6
	Normal rte	001
	Absorb	0
To Public Network:		
Routing Service	Route	002
	DialOut	No numbr
	Use	Pool PRI-A
	DN type	Public
	DestCode	9
	Normal rte	002
	Absorb	0
East End:		
Hardware	Card 1	PRI
	Protocol	SL-1
	BchanSeq	Ascend
	ClockSrc	Primary
Trk/Line Data	Line 245	Target line

Heading	Parameter	Setting
	Rec'd #	6221
Line Access	DN 6221	L245:Ring only
	Line pool access	Line pool PRI-A
To Head Office:		
Routing Service	Route	001
	DialOut	No numbr
	Use	Pool PRI-A
	DN type	Private
	DestCode	4
	Normal rte	001
	Absorb	0
To West End:		
Routing Service	DestCode	2
	Normal rte	001
	Absorb	0
To Public Network:		
Routing Service	Route	002
	DialOut	No numbr
	Use	Pool PRI-A
	DN type	Public
	DestCode	9
	Normal rte	002
	Absorb	0

Additional Configuration

In this example, outgoing public network calls dialed from a Norstar telephone are passed to the Meridian 1, and the Meridian 1 is responsible for seizing a public trunk. For this reason, the 9 prefix is left in the number passed to the Meridian 1.

This necessitates that the Public DN lengths table on each Norstar be modified to account for the extra leading digit.

Essentially, the eight pre-configured entries are modified to include a leading 9 in the prefix digits, and the length value for each entry is increased by one.

The new entries are listed below.

Prefix	Length
Default	8
90	12
900	13
901	18
9011	19
91	12
9411	4
9911	4

Carrier codes:

If a system has a different long-distance service from the local service, or if the long-distance service changes within the schedules, the routing tables can be set up to include a carrier code. You define the code under **System Programming/Access codes/Carrier codes**. You then refer this to the routing tables in **Services/Routing Service/route/Carrier codes** where you define it as part of the destination code, or part or all of the DialOut string when you set up a routing service schedule.

Meridian M1 Configuration:

- Meridian M1 is the timing master for the private network PRI connections.
- Meridian M1 uses descending mode for PRI B-channel selection.

- The Meridian M1 must recognize calls dialed to 2xxx and 6xxx numbers, and route the call over PRI to either the East or West end offices. The same applies to incoming DID calls from the public network.
- The Meridian M1 must recognize numbers starting with 9 as public numbers, whether the numbers are dialed by Meridian M1 users or by Norstar users.

MCDN Private Networking

When you use MCDN on your private network, you gain the advantages of being able to use a central voice mail/Auto Attendant system to service the entire network, as well as gaining advanced system network features, which keep network traffic flowing along the most efficient paths.

MCDN networking uses PRI SL-1 lines and the MCDN protocol firmware. You need keycodes for each of these features.

To set up calling over an MCDN network, you define a dialing plan that allows the user on any system to experience consistent dialing strings for internal and external calls. For this type of network, the DNs need to be the same length, but they do not have to be unique to the entire network.

If your network is connected to a Meridian 1, and it is the Meridian that you are using for centralized voice mail and Auto Attendant, you can use either a UDP or CDP dialing plan.

- If you use UDP, you dial a unique location code with the local telephone DN range.
- In the case of CDP, the first digit of the DN range denotes the node and is unique to each system.

However, if you are using a Norstar voice mail/Auto Attendant for your centralized voice mail, you must create the calling protocols on the network using CDP. This is a private dialing plan where the first digit of the extensions for each system is unique to that system, and all DNs on all systems are the same length.

Using a UDP dialing plan

To use UDP, the user dials this combination: ACn+LOC+DN (private or public ACcess code, LOCation code, Directory Number)

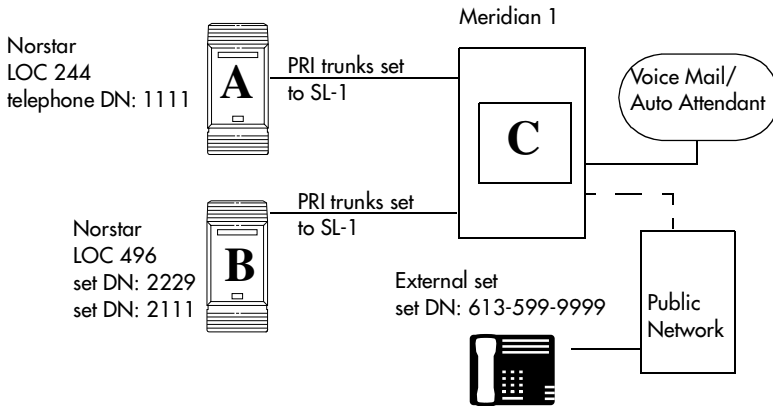

UDP call scenarios

Call scenario	LOC	Dialing String	Calling Party Number	Called Party Number
Calling to another site within the network	244	*6-668-2222	244-1111	668-2222
Calling within the node	496	2229	1111	2229
Calling the public network	244	**9-599-9999	613-763-1111 (OLI Public DN)	599-9999

LOC: This code defines the particular Norstar system.
 * Private Access Code (within network)
 **Public Access Code (out to PSTN)

UDP call routing

Heading	Parameter	Setting
A:		
Hardware	Card 1	PRI
	Protocol	SL-1
	BchanSeq	Ascend
	ClockSrc	Primary
Trk/Line Data	Line 245	Target line
	Rec'd #	1111
Line Access	DN 1111	L245:Ring only
	Line pool access	Line pool PRI-A
Dialing Plan	Private	UDP
	PrivNetID	1
	Loc Code	244
	Priv DN len	7
To C:		
Routing Service	Route	001
	DialOut	No numbr
	Use	Pool PRI-A
	DN type	Private
	DestCode	4
	Normal rte	001
Access Codes	Absorb	0
	PrivAccCode	4
To B:		
Routing Service	DestCode	6
	Normal rte	001
	Absorb	0
Access Codes	PrivAccCode	6
To Public Network:		
Routing Service	Route	002
	DialOut	No numbr
	Use	Pool PRI-A

Heading	Parameter	Setting
	DN type	Public
	DestCode	9
	Normal rte	002
	Absorb	0
Access Codes	PrivAccCode	9
B:		
Hardware	Card 1	PRI
	Protocol	SL-1
	BchanSeq	Ascend
	ClockSrc	Primary
Trk/Line Data	Line 245	Target line
	Rec'd #	2229
Line Access	DN 2229	L245:Ring only
	Line pool access	Line pool PRI-A
Dialing Plan	Private	UDP
	PrivNetID	2
	Loc Code	496
	Priv DN len	7
To C:		
Routing Service	Route	001
	DialOut	No numbr
	Use	Pool PRI-A
	DN type	Private
	DestCode	4
	Normal rte	001
	Absorb	0
Access Codes	PrivAccCode	4
To A:		
Routing Service	DestCode	2
	Normal rte	001
	Absorb	0
Access Codes	PrivAccCode	2

Heading	Parameter	Setting
To Public Network:		
Routing Service	Route	002
	DialOut	No numbr
	Use	Pool PRI-A
	DN type	Public
	DestCode	9
	Normal rte	002
	Absorb	0
Access Codes	PrivAccCode	9

Using a CDP dialing plan

To use CDP, the user dials the internal DN for the target telephone. Each node DN range starts with a unique digit.

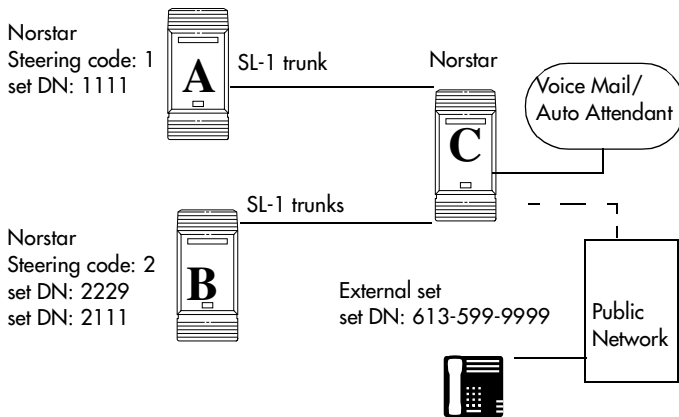

CDP call scenarios

Call scenario	Dialing String	Calling Party Number	Called Party Number
Calling to another site within the network	2229	1111	2229
Calling within the node	2229	2111	2229
Calling the public network	*9-599-9999	613-763-1111 (OLI Public DN)	599-9999
*Public Access Code (out to PSTN)			

CDP call routing

Heading	Parameter	Setting
A		
Hardware	Card 1	PRI
	Protocol	SL-1
	BchanSeq	Ascend
	ClockSrc	Primary
Trk/Line Data	Line 245	Target line
	Rec'd #	1111
Line Access	DN 1111	L245:Ring only
	Line pool access	Line pool PRI-A
Dialing Plan	Private	CDP
	PrivNetID	1
To C:		
Routing Service	Route	001
	DialOut	No numbr
	Use	Pool PRI-A
	DN type	Private
	DestCode	4
	Normal rte	001
	Absorb	0

Heading	Parameter	Setting
To B:		
Routing Service	DestCode	6
	Normal rte	001
	Absorb	0
To Public Network:		
Routing Service	Route	002
	DialOut	No numbr
	Use	Pool PRI-A
	DN type	Public
	DestCode	9
	Normal rte	002
	Absorb	0
B:		
Hardware	Card 1	PRI
	Protocol	SL-1
	BchanSeq	Ascend
	ClockSrc	Primary
Trk/Line Data	Line 245	Target line
	Rec'd #	2229
Line Access	DN 2229	L245:Ring only
	Line pool access	Line pool PRI-A
Dialing Plan	Private	CDP
	PrivNetID	2
To C:		
Routing Service	Route	001
	DialOut	No numbr
	Use	Pool PRI-A
	DN type	Private
	DestCode	4
	Normal rte	001
	Absorb	0

Heading	Parameter	Setting
To A:		
Routing Service	DestCode	2
	Normal rte	001
	Absorb	0
To Public Network:		
Routing Service	Route	002
	DialOut	No numbr
	Use	Pool PRI-A
	DN type	Public
	DestCode	9
	Normal rte	002
	Absorb	0

MCDN trunk call features

The table below lists the MCDN features that are provided by an SL-1 link with MCDN active (the keycode is installed). The features affect call redirection and trunking functions, as shown in the table below.

MCDN network features

- | | |
|-----------------------|---|
| Centralized messaging | <ul style="list-style-type: none"> • network call redirection information (NCRI) |
| Centralize trunking | <ul style="list-style-type: none"> • ISDN call connection limitation (ICCL) • trunk route optimization (TRO) • trunk anti-tromboning (TAT) |

Network Call Redirection Information

NCRI builds on the following call features:

- External Call Forward
- Call Transfer
- Call Forward

NCRI adds the ability to redirect a call across an MCDN network using Call Forward (all calls, no answer, busy) and Call Transfer features. The call destination also receives the necessary redirection information. This feature allows the system to automatically redirect calls from within a Norstar system to the Meridian Mail system, which resides outside the Norstar system on a Meridian 1 or another Norstar.

The figure below shows an example of this situation, where user A calls user B on the same Norstar system. If user B is busy or not answering, the call automatically gets transferred to a Meridian Mail number (user C) across an MCDN link between the Norstar system and the Meridian 1 system (or another Norstar system) where the mailboxes are set up.

Network call redirection path

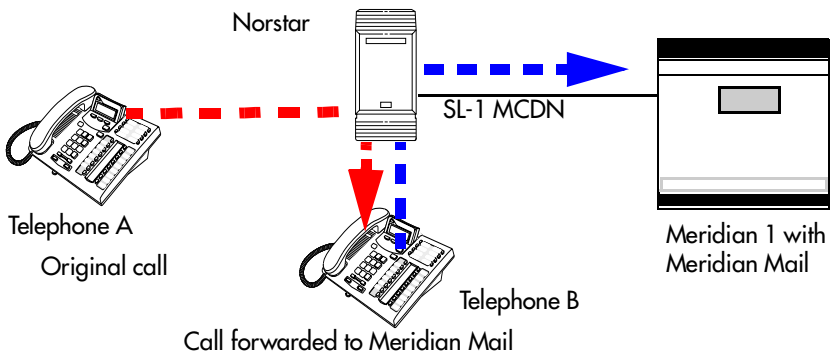

If you are using the centralized voice message system from a Meridian 1 system, you require the following programming on the M1:

M1 programming in LD 17

- NASA set to Yes
- NCRD set to Yes

Verifying NASA is Active <ul style="list-style-type: none"> • Overlay 22, LD 22 • REQ: PRT • TYPE: ADAN DCH (slot number) • NASA should be set to yes 			
If NASA is not on:	Disable the D channel <ul style="list-style-type: none"> • Overlay 96, LD 96 • REQ: CHG • TYPEDIS DCH 	Disable the loop <ul style="list-style-type: none"> • Overlay 60, LD 60 • REQ: CHG • TYPE: DISL (slot number) 	Program the D channel <ul style="list-style-type: none"> • Overlay 17, LD 17 • REQ: CHG • TYPE: ADAN • ADAN: CHG DCH (slot number) • Keep pressing enter until you get to NASA • TYPE: yes • TYPE: end
Verifying NCRD <ul style="list-style-type: none"> • Overlay 20, LD 20 • REQ: PRT • TYPE: TIE • CUST: 0 • Route: Enter the route defined in LD 20 • Keep pressing enter until all values are displayed. Check if NCRD is yes. 		If NCRD is set to no <ul style="list-style-type: none"> • Overlay 16, LD 16 • REQ: CHG • TYPE: RDB • CUST: 0 • ROUT: (route number) from LD 20 • Keep pressing enter until you get NCRD and type Yes • Keep pressing enter until you get the REQ prompt again • TYPE: end 	

ISDN Call Connection Limitation

The ICCL feature piggybacks on the call initiation request and acts as a check at transit PBX points to prevent misconfigured routes or calls with errors from blocking channels.

This feature adds a transit/tandem counter to a call setup message. This counter is compared at each transit PBX with a value programmed into the transit PBX, in a range from 0 to 31. If the call setup counter is higher than the PBX value, the call will be blocked at the PBX and cleared back to the network. This prevents calls from creating loops that tie up lines.

Norstar configurations:

- Setting ICCL
 1. With the display showing `System Prgrming` press until the display shows `NetworkServices`.
 2. Press until `MCDN` displays.
 3. Press . `NetwkICCL:` displays.
 4. Press **CHANGE** to choose either **Y** (yes) or **N** (no)
- Under Hardware, define Maximum transits for the card.

The diagram below demonstrates how a call might loop through a network if the system is **not** set up with the ICCL feature.

Call loop on system without ICCL

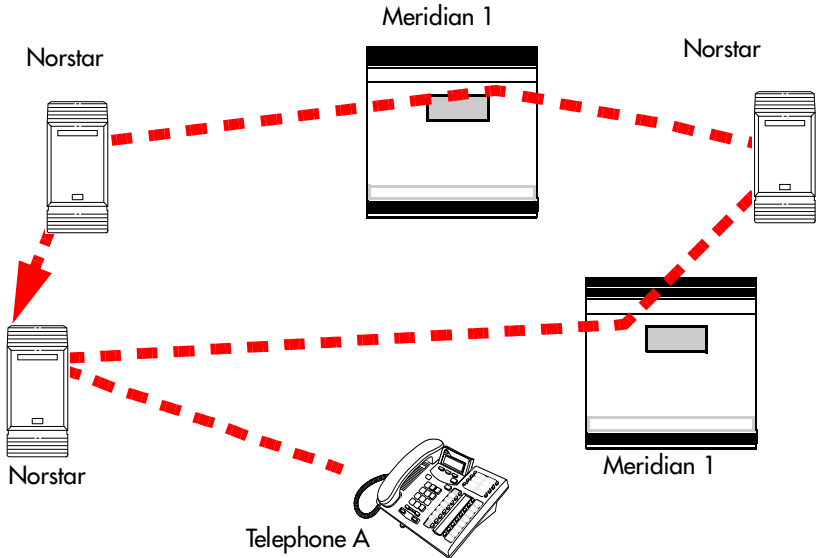

Meridian configurations:

The following settings are required on the Meridian system, using LD15:

- REQ = CHG
- TYPE = CDB
- Net_DATA=Yes
- CUST=0
- ISDN=Yes
- RCNT(5)
- PSTN=No
- TNDM=0-31(15)
- PCMC=0-31(15)
- SATD=0-5(1)
- Number plan CDP, UDP, and access code configured using LD 86, 87 and LD90

Trunk Route Optimization

TRO finds the most direct route through the network to send a call between nodes. This function occurs during the initial alerting phase of a call.

Business Communications Manager configurations:

- Under Network Settings, MCDN, set TRO to Y(yes).
- Configure call routing for all optimal routes.
- Configure Call Forward (All Calls, No Answer, Busy) or Selective Line Redirection to use the optimal routes.

This feature avoids the following situation: A call originating from a Norstar system may be networked to a Meridian system, which, in turn, is networked to another Meridian system, which is the destination for the call. If the call routes through the first Meridian (M1) to reach the second Meridian (M2), two trunks are required for the call. An optimal choice is a straight connection to M2. TRO finds these connections and overrides the less-efficient setup.

The following figure shows two call paths. The first route, through the Meridian, demonstrates how a call might route if TRO is not active. The second route, that bypasses the Meridian, demonstrates how TRO selects the optimum routing for a call.

Call paths with and without TRO

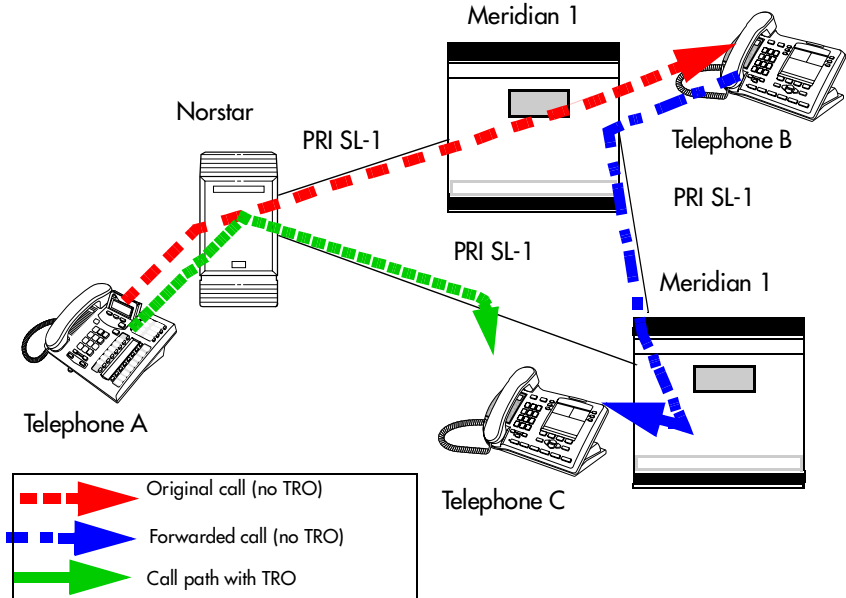

If you are using a Meridian 1 system as part of the network, you need the following programming for each system:

```
M1 TRO set to yes for Card1/Mod 1
Norstar route:
LD 16
TYPE: RDB
Cust: xx
Rout: 0-511
TRO: Yes
```

Norstar configuration:

1. With the display showing **System Programming** press until the display shows **NetworkServices**.
2. Press until **MCDN** displays.
3. Press . **NetwkICCL:** displays.
4. Press until **TRO:Y** displays.

5. Press **CHANGE** to choose either **Y** (yes) or **N** (no).

Trunk Anti-tromboning

TAT is a call-reroute feature that works to find better routes during a transfer of an active call. This feature acts to prevent unnecessary tandeming and tromboning of trunks. This action occurs after the speech path has been established.

Note: This feature is not applicable for alerting calls.

This feature does not activate if TRO is set to yes.

Norstar configuration:

1. With the display showing **System Prgrming** press until the display shows **NetworkServices**.
2. Press until **MCDN** displays.
3. Press . **NetwkICCL:** displays.
4. Press until **TAT** displays.
5. Press **CHANGE** to choose either **Y** (yes) or **N** (no).

Meridian configuration

The following must be set on the Meridian 1 before this feature can activate:

- MCDN PRI D-channel must have TAT set to yes (using LD17 and TRMB in LD17)
- 1.5 MB/2MB DTI/PRI card configured as PRI with interface type of SL1
- NCRD parameter set to yes for the MCDN PRI routes
- Remote capabilities configured for the D-channel (using LD 17) to include ND2

The diagram below shows how TAT reduces the line requirements. The solid line shows Telephone A calling Telephone B and being transferred over an additional PRI line to Telephone C. With TAT active, the same call is transferred to Telephone C over the same PRI line.

Call paths with and without TAT

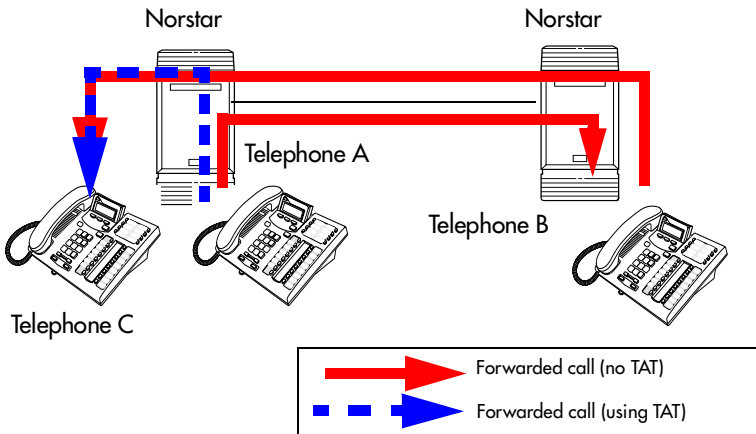

MCDN voice mail/auto attendant call features

Besides the general MCDN features described in *MCDN trunk call features* on page 133, an MCDN connection with a Meridian 1 with attached voice mail system, also provides some special call features, as described below.

MCDN Meridian 1 attendant MCDN features

- Meridian attendant features
- camp-on
 - break-in

Note: Although these features have the same functions as Camp-on and Priority calls within each Norstar system, MCDN camp-on and break-in from M1 can access all network telephones connected to the centralized voice mail system.

To all Norstar systems on the private network, the centralized voice mail system is viewed as an external call by each system, even though the dialing plan configurations makes it seem like callers are making local calls.

Camp-on

A call received by the Meridian attendant can be assigned to a telephone anywhere in the MCDN network, when the following situations are valid:

- the target telephone rings busy when the attendant calls
- no free keys on target telephone
- DND regular feature is inactive
- DND on busy feature is inactive

The target user sees that there is a call camped on the telephone. The called user can then clear a busy lines and take the call, or the user can choose to reject the call, using F814, or the user can indicate Do Not Disturb, using F85.

The diagram below demonstrates the call path for a Meridian attendant to camp a call on a telephone in the Norstar system.

Camping a call on a network telephone

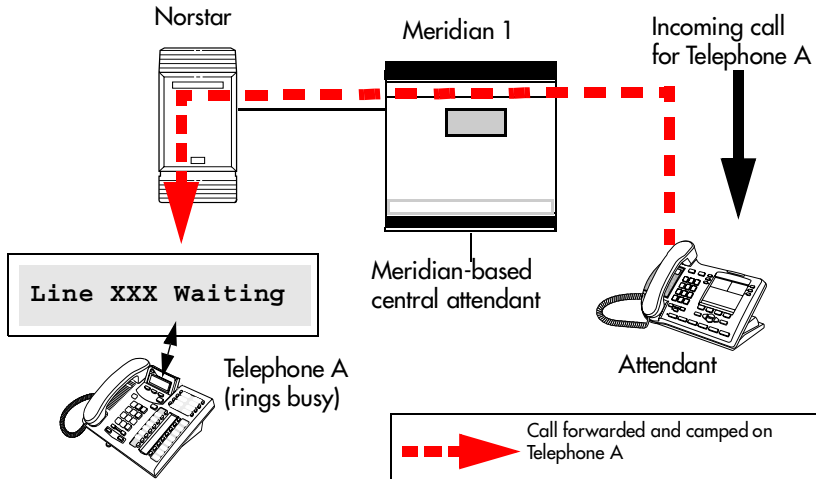

Break-in

The Meridian attendant can break into an on-going call from a telephone in the Norstar system, if these situations are valid:

- Target Norstar telephone is busy but still has a free intercom or line key.
- DND busy is turned on, although the attendant can override a busy signal, if it is turned off, by pressing the **BKI** key.
- Prime set also should be busy, with no free key, and with DND turned on.
- Attendant capability is high (2), and higher than either the target telephone or the caller the target telephone owner is busy with.

A warning tone occurs for both parties on the call before the actual break-in occurs.

The diagram below demonstrates the call path for a Meridian attendant to break into a call between telephones in the Norstar system.

Breaking into a Norstar call path

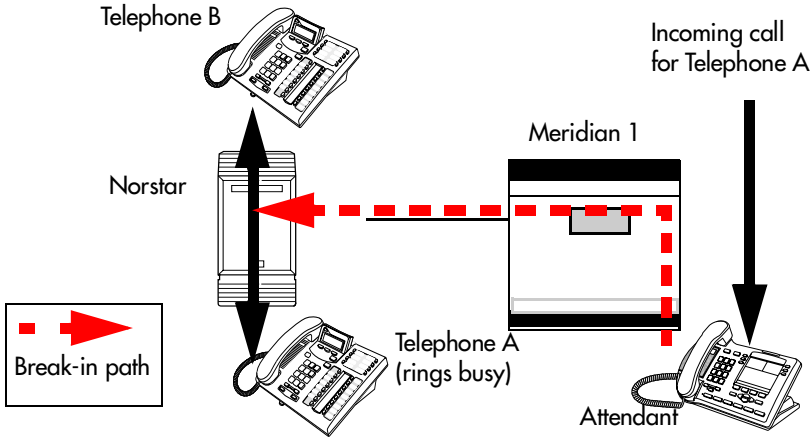

Break-in can be accomplished using two methods:

- Pre-dial BKI:
 1. Attendant presses BKI button on telephone.
 2. Attendant dials the destination number.
 3. On receiving a busy signal, the Attendant presses BKI again.

The attendant is given access to the conversation.

- Post-dial BKI: Attendant:
 1. Attendant dials destination number.
 2. If a camp-on or busy tone is heard, the attendant presses the BKI button on the telephone.

The attendant is given access to the conversation.

You can set a level of priority that will determine if a telephone will allow an attendant to break in. This is referred to as setting the Intrusion level.

How the intrusion hierarchy works:

- Break-in allowed if Attendant telephone is High and caller telephone is Medium.
- Break-in is not allowed if Attendant telephone is Medium and caller telephone is high.

Set the Intrusion level for each telephone under Capabilities.

1. At **Terminals&Sets**, press and enter the DN number for the telephone to which you want to add intrusion levels.
The telephone displays `<set number>: <set number>` or `<name>`.
2. Press . The display shows **Line Access**.
3. Press until you reach **Capabilities**.
4. Press . The display shows **Fwd no answer**.
5. Press until you reach **Intrusion**.
6. Press . The display shows **Protect lvl**.
7. Press **CHANGE** to select **None**, **Low**, **Med**, or **High**.

Central voice mail and Auto Attendant with Norstar

You can use Norstar voice mail (NVM) and Auto Attendant running on a Norstar Application module (NAM) platform as the central voice mail/auto attendant node for your MCDN network. However, this configuration does not allow centralized camp-on or break-in, since these are Meridian-voice-mail-based features.

Using NVM requires that all nodes on the network are set up with the CDP dialing rules. You can have a maximum of 10 nodes on a Norstar-based network if you use all three DTI cartridges.

Note: Ensure you have the latest version of NVM if you want to set up this type of centralized system.

Configuring centralized voice mail

System configuration for centralized voice mail depends on where the NAM is connected. The system with the NAM is configured using the voicemail DN and a target line. The systems that are remote to the NAM are configured through the Telco features sections.

Installation instructions about installing Norstar voice mail as a centralized voice mail system, are explained in the addendum titled: *Installing Norstar Voice Mail as a Centralized Voice Mail System*. This addendum includes details about voice mail configuration as well as the Norstar Modular ICS configuration that is included in the following sections.

Local system

To set up the local system, you need to assign a target line to the DN for the voice mail system, then enter that DN into the target line record.

1. After you enter your password, at the **Terminals&Sets** prompt, press .
The prompt displays: **Show set:**
2. Enter the DN number for the voice mail system.
3. Press . The prompt displays **Line access**.
4. Press . The prompt displays **Line assignment**.
5. Enter the target line number for your voice mail system.
6. Press **CHANGE** to change the setting for each line to one of the following: **Unassigned**, **Ring only**, **Appr&Ring**, and **Appr only**.
7. Press until you reach the top level, then press . The prompt displays **Lines**.
8. Press . The prompt displays **Show line**.
9. Enter the target line number you entered in step 5.
10. Press . The prompt displays **Trunk/line data**.
11. Press . The prompt displays **Line Type**.
12. Press . The prompt displays **Rec'd #**.
13. Enter the DN for the voice mail system.
14. Exit programming.

Remote system

On the nodes that are not directly connected to the central voice mail system, you need to use the Telco Features headings to identify the route to the voice mail system.

1. After you enter your password, press until the prompt displays **Telco Features:**
2. Press . The prompt displays **VMs9 Center tel#s.**
3. Press . The prompt displays **VMs9 Center 1.**
4. Press . The prompt displays **Use:**
5. Press **CHANGE** to until you reach **Routing tbl.**
6. Press . The prompt displays **Tel #:**
7. Enter the number to access the external voice mail system.

Set Telco features for the VM DN

1. Press until you reach the top level, then press until the prompt displays **Terminals&Sets.**
2. Press . The prompt displays: **Show set:**
3. Enter the DN for the voice mail system.
4. Press . The prompt displays **Line access.**
5. Press until the prompt displays **Telco features.**
6. Press . The prompt displays **Feature Assign.**
7. Press . The prompt displays **Show line.**
8. Enter the line number that connects to the system for the central voice mail system.
9. Press . The prompt displays **Caller ID Set.**

10. Press until the prompt displays **Ext1 VMs9 set.**
11. Press **CHANGE** to select **Y** (yes).

Set Telco features for the target line

1. Press until you reach the top level, then press until the prompt displays **Lines.**
2. Press . The prompt displays: **Show line:**
3. Enter the target line number for the voice mail system.
4. Press . The prompt displays: **Trunk/line data:**
5. Press until the prompt displays **Telco features.**
6. Press . The prompt displays **VMs9 Center 1.**
7. Press . The prompt displays **Use:**
8. Press **CHANGE** to until you reach **Routing tbl.**
9. Press . The prompt displays **Tel #:**
10. Enter the number to access the external voice mail system.
11. Exit programming.

Using centralized voice mail

If you use NVM, ensure that you provide the correct user cards for system access. Users with telephones connected to the Meridian or Norstar unit on which NVM is installed, use internal voice mail feature codes to use the system (F981, and so on). Users on other nodes of the system, use the remote access codes, which are similar to the codes they would use if the central voice mail system was the Meridian-based system.

Note: Meridian mail and Norstar voice mail can co-exist on the same Meridian, however, users can only be configured for one of the systems.

Configuring Centralized Auto Attendant (CAA)

System configuration for centralized Auto Attendant depends on where the NAM is connected. The system with the NAM is configured using the CAA DN and a target line. The systems that are remote to the NAM are configured through the Telco features sections.

All nodes must have a unique Private Network Identifier (PNI), which is defined under Dialing Plan. On each node, as well, the PNIs of adjacent nodes are programmed under Hardware.

Assigning PNIs

1. After you enter your password, press until the prompt displays **System Programming:**
2. Press . The prompt displays **Hunt Groups.**
3. Press until the prompt displays **Dialing Plan.**
4. Press . The prompt displays **Private Network.**
5. Press . The prompt displays **Type.**
6. Press **CHANGE** to until you reach **CDP.**
7. Press . The prompt displays **PrivNet.ID.**
8. Enter the private network ID for your system.

Assigning PNIs for adjacent nodes

1. After you enter your password, press until the prompt displays **Hardware:**
2. Press . The prompt displays **Show module.**
3. Enter the module where the PRI card you have configured for SL-1 resides.
4. Press . The prompt displays **CdX-KSU.**
5. Press . The prompt displays **Card type.**
6. Press . The prompt displays **Lines.**
7. Enter the line number you want to configure.
8. Press . The prompt displays **Protocol.**
9. Ensure that this displays **SL-1.**
10. Press . The prompt displays **PrivNetID:**.
11. Enter the PNI of the adjacent node.
12. Repeat these steps for all the nodes that are directly adjacent to your system.

Local system

To set up the local system, you need to assign a target line to the DN for the voice mail system, then enter that DN into the target line record.

1. After you enter your password, at the **Terminals&Sets** prompt, press .
The prompt displays: **Show set:**
2. Enter the DN number for the Auto Attendant.
3. Press . The prompt displays **Line access.**

4. Press . The prompt displays **Line assignment.**
5. Enter the target line number for the Auto Attendant system.
6. Press **CHANGE** to change the setting for each line to one of the following: **Unassigned**, Ring only, Appr&Ring, and Appr only.
7. Press until you reach the top level, then press . The prompt displays **Lines.**
8. Press . The prompt displays **Show line.**
9. Enter the target line number you entered in step 5.
10. Press . The prompt displays. The prompt displays **Line Type.**
11. Press . The prompt displays **Rec'd #.**
12. Enter the DN for the Auto Attendant system.
13. Exit programming.

Remote system

On the nodes that are not directly connected to the central Auto Attendant system, you need to use the Telco Features headings to identify the route to the system.

1. After you enter your password, press until the prompt displays **Telco Features:**
2. Press . The prompt displays **VMs9 Center tel#s.**
3. Press . The prompt displays **VMs9 Center 1.**
4. Press . The prompt displays **Use:**
5. Press **CHANGE** to until you reach **Routing tbl.**

6. Press . The prompt displays **Tel #:**.
7. Enter the number to access the external Auto Attendant system.

Set Telco features for the CAA DN

1. Press until you reach the top level, then press until the prompt displays **Terminals&Sets.**
2. Press . The prompt displays: **Show set:**
3. Enter the DN for the Auto Attendant system.
4. Press . The prompt displays **Line access.**
5. Press until the prompt displays **Telco features.**
6. Press . The prompt displays **Feature Assign.**
7. Press . The prompt displays **Show line.**
8. Enter the line number that connects to the system for the central voice mail system.
9. Press . The prompt displays **Caller ID Set.**
10. Press until the prompt displays **Ext1 VMs9 set.**
11. Press **CHANGE** to select **Y** (yes).

Set Telco features for the target line

1. Press until you reach the top level, then press until the prompt displays **Lines.**
2. Press . The prompt displays: **Show line:**
3. Enter the target line number for the voice mail system.
4. Press . The prompt displays: **Trunk/line data:**

5. Press until the prompt displays **Telco features.**
6. Press . The prompt displays **UMsg Center 1.**
7. Press . The prompt displays **Use#:**
8. Press **CHANGE** to until you reach **Routing tbl.**
9. Press . The prompt displays **Tel #:**
10. Enter the number to access the external Auto Attendant system.
11. Exit programming.

Voice mail configuration

On the voice mail system, set the following parameters:

- Set Redirected DN to Yes.
- Under the F983 AA prompt, set ANS: Y for the voice main DN assigned target line.
- Under F983 dial 77 and set External init as Y.
- From the CVM/CAA lines, use the default greeting table 1.

For detailed directions, refer to the addendum titled: *Installing Norstar Voice Mail as a Centralized Voice Mail System.*

Customer Use

This section shows sample configurations for different types of network access. Each example has four parts:

- A scenario explains the goal of the call and what is required to achieve it.
- A diagram shows the network configuration that supports the application.
- A list shows the Norstar hardware required to support the configuration.
- Tables show the programming. Only those settings that are important to network access are described.

Public network

The calls described in this section all originate from the public network. Callers dial in using a public DN into the system.

Call one or more Norstar telephones

Ms. Nelson is a bank customer with a question for an accountant. She dials the number that maps onto target line 203. All of the telephones ring in the accounting department.

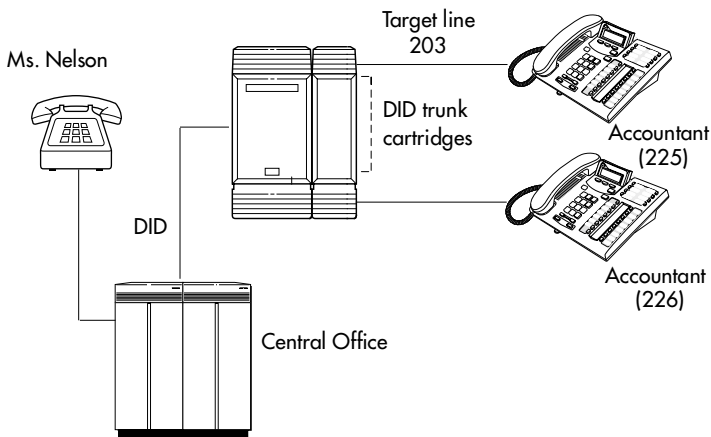

Hardware: ICS, a Trunk Module with a DID Trunk Cartridge, or a DTI with lines programmed as DID.

Heading	Parameter	Setting
Trk/Line Data	Rec'd # Line 051	4321 (for Line 203) DID
Rec'd # length	Rec'd # length	four digits (can be from three to seven digits, but must match number of digits sent by central office)

Call Norstar and select tie lines to a private network

A manager in Georgia wants to use the tie lines at headquarters to call Washington. He dials a telephone number that maps onto the DISA DN, enters a Class of Service (COS) password, then dials a line pool access code to select a tie line to Washington.

Using tie lines

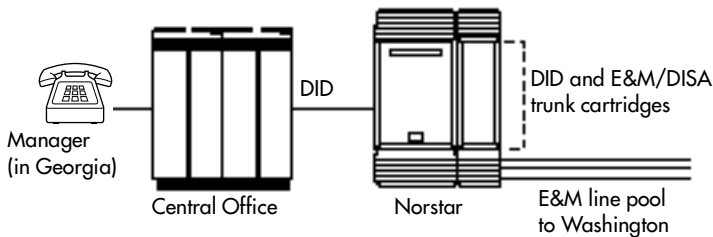

Hardware: ICS, a Trunk Module with a DID Trunk Cartridge, two E&M/DISA Trunk Cartridges for the three trunks in the line pool to Washington, or a DTI with one DID line and three E&M lines.

Heading	Parameter	Setting
Incoming trunk:		
Trk/Line Data	Line 049	DID
Access codes	DISA DN	5321

Heading	Parameter	Setting
Rec'd # length	Rec'd # length	four digits (three to seven digits, but must match number of digits sent by central office)
Outgoing trunk:		
Trk/Line Data	Line 053 Line type	E&M Pool F
Access codes	Line pool F	6 (up to four digits)
COS pswds		Define restrictions. Define remote access pkgs. Assign a restriction filter to the line. Assign COS passwords and filters for each Class of Service.

Call Norstar and select lines to the public network

Gord wants to make a long-distance business call from home. To avoid being charged, he dials the telephone number that maps onto the Auto DN at work. After hearing the dial tone, Gord dials a line pool access code to select a line to the public network. He then dials the long-distance number.

Using DID to dial long-distance

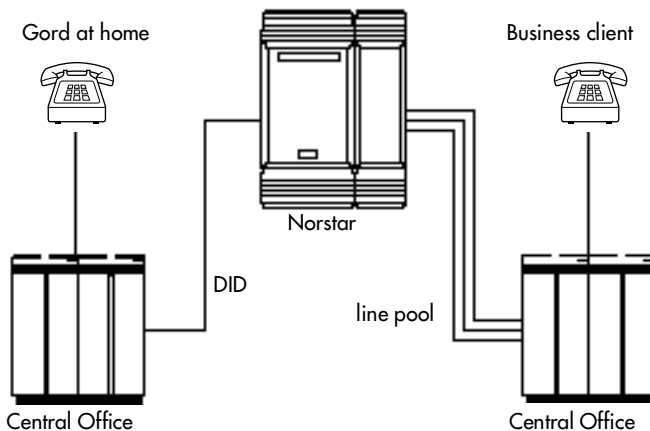

Hardware: ICS, a Trunk Module with a DID Trunk Cartridge or DTI with several DID lines.

Heading	Parameter	Setting
Incoming trunk:		
Trk/Line Data	Line 049	DID
Access codes	Auto DN	4321
Rec'd # length	Rec'd # length	four digits (can be from three to seven digits, but must match number of digits sent by central office)
Lines /Restrictions and Remote access		Define restriction filters. Define remote access packages. Assign a remote restriction and remote package to the line.
Outgoing trunk:		
Trk/Line Data	Line 001 Line type	Loop Pool A
Access codes	Line pool A	1234
Lines /Restrictions		Assign a restriction filter to the line.

Private network

All the calls described in this section originate from within the networked system.

Call one or more Norstar telephones

The production supervisor in Houston selects the less-expensive company Tie line to call the manager at the Administration office in Dallas. Once the line is selected, the production supervisor dials the digits that will map onto the target line of the manager in Dallas.

Calling from a Norstar to a remote PBX

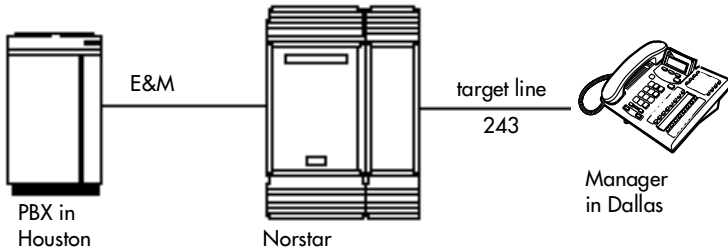

Hardware: ICS, a Trunk Module with an E&M/DISA Trunk Cartridge or a DTI with an E&M line.

Heading	Parameter	Setting
Incoming trunk:		
Trk/Line Data	Rec'd #	4321(for target line 243)
	Line 049	E&M
	Ans Mode	Auto
Rec'd # length	Rec'd # length	four digits (can be from three to seven digits, but must match number sent by central office)

Use tie lines to other nodes in the private network

At a branch office, Joan selects a tie line to the main office. After hearing the dial tone, she dials a line pool access code to select another tie line to a branch office in the next state.

Calling within the network through Tie lines

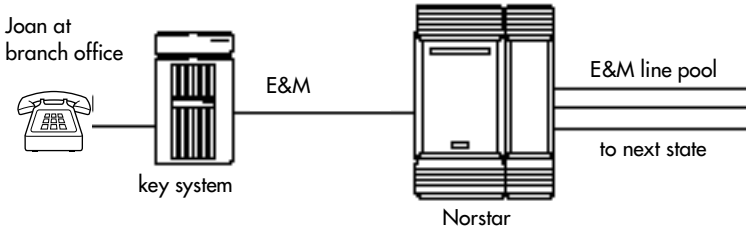

Hardware: ICS, a Trunk Module with two E&M/DISA Trunk Cartridges, for the three lines in the line pool and the one incoming line, or a DTI with four E&M lines.

Heading	Parameter	Setting
Incoming trunk:		
Trk/Line Data	Line 049 Ans mode	E&M Auto
Under Lines / Restrictions / Remote access		Define restriction filters. Define remote access packages. Assign a remote restriction and remote package to the trunk.
Outgoing trunk:		
Trk/Line Data	Line 050 Line type	E&M Pool D
Access codes	Line pool D	71 (can be from one to four digits)
Lines / Restrictions		Assign a restriction filter to the trunk.

Select lines to the public network

Liz in Memphis, needs to call long-distance to a client in New York. She selects a tie-line to the branch office in New York. After hearing the dial tone, she dials a line pool access code to select a line to the public network. Then, she dials the external number as a local call.

Using a Tie line and line pool to call remote PSTN

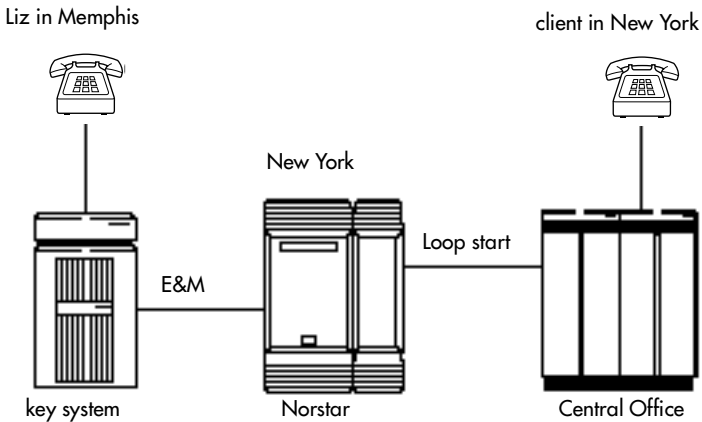

Hardware: ICS, a Trunk Module with an E&M/DISA Trunk Cartridge or DTI with an E&M line.

Heading	Parameter	Setting
Incoming trunk:	Line 049	E&M
Trk/Line Data	Ans mode	Auto
Under Lines / Restrictions and Remote access		Define restriction filters and remote access packages. Assign a remote restriction and remote package to the trunk.
Outgoing trunk:		
Trk/Line Data	Line 001	Loop
	Line type	Pool B
Access codes	Line pool B	73 (can be one to four digits)

Heading	Parameter	Setting
Lines / Restrictions		Assign a restriction filter to the line.

Select E&M trunks to the private network

For a confidential call, the Montana sales manager presses the line button for a private E&M trunk to the Oregon office. This automatically alerts at the line appearance on the telephone of the Oregon sales manager.

Using private E&M trunks for remote calls

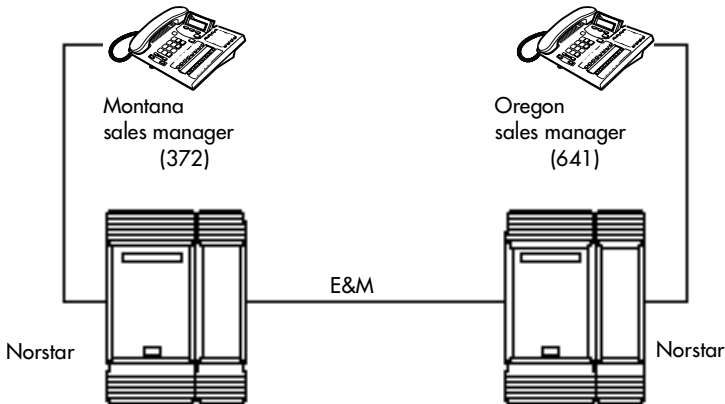

Hardware: (for both systems) ICS, a Trunk Module with an E&M/DISA Trunk Cartridge or a DTI with an E&M line.

Heading	Parameter	Setting
Montana:		
<i>Outgoing trunk:</i>		
Trunk Data (Line 049)	Line	E&M
Line Data (Line 049)	Line type	Private to 372

Heading	Parameter	Setting
Oregon:		
<i>Incoming trunk:</i>		
Trunk Data	Line	E&M
(Line 057)	Ans mode	Manual
	Line type	Private to 641

Norstar Line Redirection feature

The branch office is receiving more calls than it can handle, so it redirects one of its lines to the main office. All calls that come in on target line 232 will be routed out on line 003 to the main office. Whenever a call is redirected, the target line and outgoing line will be busy for the duration of the call.

Line redirection routes

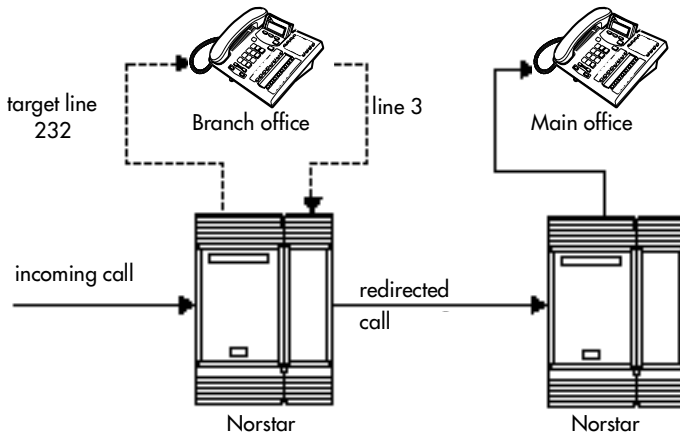

Hardware: ICS, an E&M/DISA Trunk Cartridge if the incoming trunk is E&M or a DID Trunk Cartridge if the incoming trunk is DID, or a DTI with one E&M line or one DID line.



Tips - Any line appearance on a telephone can be selected as the incoming line to be redirected. Restriction filter restrictions on the line are checked against the filter in effect at the time a call is redirected not when redirection is programmed.

A target line cannot be selected as the outgoing line for redirection.

The incoming trunk must have disconnect supervision.

Heading	Parameter	Setting
Incoming trunk:	Line 001:	Loop
Trk/Line Data	Trunk mode:	Super
	Ans mode:	Auto
	OR	
	Line 049:	DID
	OR	
	Line 053:	E&M
	Ans mode:	Auto
	Rec'd #:	4321
	(for target line 232)	
Rec'd # length	Rec'd # length:	four digits (can be from three to seven digits, but must match number of digits sent by central office)
Outgoing trunk:	Line 003:	Loop
Trk/Line Data	OR	
	Line 054:	E&M
Capabilities	Allow redirect:	Y

ETSI MCDN and network features

If your system is running Profile 2, and you are using ETSI PRI lines with SL-1 MCDN protocol to network your systems, your network has access to all the MCDN features described in the preceding sections. MCDN features are set up under **Network Features, MCDN**.

In addition, ETSI lines can provide the following CO network features. Availability of these features is first determined by your service provider, and secondly by turning on the features under **Network Features, ETSI**.

Network Call Diversion

Norstar Network Call Diversion (NCD) is a network function that allows forwarding and redirection of calls outside the Norstar network when using an ETSI ISDN line. Functionality is similar to that of External Call Forward (ECF).

NCD redirects calls using the same line on which they arrive. Call forward is efficient since there is no need for additional outside lines.

Forwarding calls externally from an extension requires the user to enter either a Destination Code or Line Pool Access Code, and the number to which calls will be forwarded.

Examples of NCD include:

- redirecting all calls from an extension to a mobile phone
- forwarding calls to an external destination (rather than to voicemail), when an extension is busy or the user is unavailable.

Allowing NCD

To use NCD, you must turn the feature on in Network Services.

1. Press until the display reads **System Programming**.
2. Press . The display shows **Hunt Groups**.
3. Press until the display shows **Network Services**.
4. Press . The display shows **Network Redirection: N**.
5. Press **CHANGE** and set to yes.

Feature description

NCD is available only over ETSI ISDN lines. It can be invoked when calls are presented to Norstar/BST extensions over ISDN lines. The user must program the selected extension. Refer to *External call forwarding* on page 44

NCD is integrated with the following existing Norstar Call Forward features:

- Call Forward Unconditional (CFU)—implemented on Norstar Call Forward All Calls (CFAC) , and Selective Line Redirection (SLR) , also referred to as Line Redirection. This is programmable by the user.
- Call Forward on Busy (CFB)—implemented on Norstar Call Forward Busy.
- Call Forward on No Response (CFNR)—implemented on Norstar Call Forward No Answer.

For example:

- When a call comes in on ETSI ISDN and is returned to a destination being serviced by ETSI ISDN, BTNR 191, Analogue or DASS2 lines, then ETSI Call Forward (CFU, CFB or CFNR) is used.
- When a call comes in on ETSI ISDN and is returned to a private network destination over DPNSS, then External Call Forward (ECF) is used.
- When a call comes in on DPNSS 1 and is returned on any line type except DPNSS 1, ECF is used. If that call is returned over DPNSS, however, then DPNSS 1 Diversion (DIV) is used. Refer to *Network Call Diversion* on page 165
- When a call comes in on any other line type, such as AC15A, then again ECF is used. Note that under certain line conditions, ECF will not work; refer to Line Redirection restrictions.

Note: In all cases, if NCD fails due to network errors or rejections, Norstar invokes ECF. If an outgoing line is unavailable, Norstar routes the call to the line's prime extension.

Programming and restrictions

NCD features are accessed through existing Norstar features. Extensions requiring redirection must be programmed individually to either CFAC or SLR. CFB or CFNA must be set during programming. `Allow redirect` must be set to `Yes` for each extension, in `Terminals&Extns/Capabilities`.

Note: Any other programming applied to specific lines and extensions take precedence, for example `Restrictions(extns)` under `Terminals&Extns`.

NCD is used as long as the affected lines are ETSI ISDN, and the affected DIA lines are accessible via ISDN lines. Incoming calls are diverted back to the ISDN. If NCD fails due to network errors, ECF is invoked. If ECF cannot be executed, the incoming call is routed to the line's prime extension.

**ATTENTION!**

If a line is configured to appear on several extensions with redirection programmed, predicting which extension will divert the call is not possible. This should be considered during system configuration.

An extension with CFB, CFNA and CFAC programmed will give priority to CFAC for diversion.

Selective Line Redirection

Selective Line Redirection (SLR), also referred to as Line Redirection, is enhanced for use with digital lines and operates in conjunction with NCD.

Diversion by SLR takes precedence over diversion by CFAC. An SLR line cannot be diverted by CFAC. If the call arrives on an extension with SLR programmed, a ring splash will sound (if programmed).

For information on SLR restrictions refer to *Selective Line Redirection* on page 168. For information on redirecting lines see Line Redirection in the *Modular Plus System Administration Guide*.





Programming Extensions

The User Interface for programming NCD is the same as for ECF.

Different types of Call Forward are available depending on the extension being programmed. Programming an extension to forward calls externally requires the user to enter a destination code or line pool number, in addition to the external phone number. Therefore, care should be taken to identify your network line types and record the available codes and line pools.

Enhanced Caller ID

When a Norstar/BST extension which has Call Line Identifier (CLID) active receives a redirected call due to NCD, the user will see the DN for the Calling Number. This is followed by a “>” and the redirecting number. This is displayed for as long as the call is active (alerting or answered) at that telephone.

If the alerting extension is not the CLID extension for that line, the line appearance can be pressed to briefly display the information. Pressing     or **INFO** while the call is active invokes Call Info. Call Info on DPNSS displays the redirecting number and the reason for the redirection.

Note: When Norstar requests that an incoming call be redirected by the distance network, Norstar does not inform the network of the redirecting DN. In this case, the diverted-to party will not see the diverting party DN.

Malicious caller identification (MCID)

The MCID feature allows you to use to have call information recorded on the central office system for an incoming call on a specific line (EUROISDN lines, only).

The user must invoke the feature code without hanging up, and within 30 seconds (time varies on different networks) after the caller hangs up.

Note: This feature must be allowed in network programming to work. Check with your system administrator.

The following information registers on the network:

- called party number
- calling party number
- local time and date of the invocation in the network serving the called user
- service provider option: calling party subaddress, if provided by calling user)

Programming MCID capability

To allow MCID functionality on your system, you must turn the feature on in Network Services.

1. Press until the display reads **System Programming**.
2. Press . The display shows **Hunt Groups**.
3. Press until the display shows **Network Services**.
4. Press . The display shows **ETSI**.

5. Press . The display shows **Network Redirection: N.**
6. Press . The display shows **MCID: N.**
7. Press **CHANGE** and set MCID to yes.

Examples of ISDN Scenarios

For information on various ISDN scenarios that may help you to decide on the data solution that is best for you, refer to the following web site: <http://www.nortelnetworks.com/support> and perform a Search for **TIPS**. You will need your user name and access code.

If you do not have a user name and access code, the site provides information about how to get access to this site.

ISDN applications

ISDN terminal equipment delivers a wide range of powerful business applications:

Video conferencing and video telephony

Video conferencing offers instant visual and audio contact between distant parties using either studio-based or desktop ISDN terminals.

Desktop conferencing

ISDN allows computer users in distant locations to share and edit any image, data or text file on their own computer screens while they discuss the information.

File transfer

The ISDN network allows you to transfer files containing data, text, images, data, or audio clips, faster and cheaper than with a conventional modem.

Telecommuting

Convenient retrieval, processing and storage of files is possible for the employee working at home by using ISDN lines to give high-speed access to information resources at the office.

Group 4 fax

ISDN fax applications save money by increasing both transmission speed and the quality of resolution.

Remote LAN access

ISDN provides an affordable and fast means for employees at remote sites, such as at home or in branch offices, to access local area networks (LANs).

Leased line backup

Essential backup for leased lines can be provided using ISDN, as required, rather than duplicating costly permanent leased lines.

LAN to LAN bridging

Local area network (LAN) bridge/routers allow flexible interconnection between LANs using ISDN, with charges only incurred when information is actually transmitted.

Internet and database access

The fast call set up and high bandwidth of ISDN are ideal for accessing information services such as the Internet and databases.

Planning the installation



Only qualified persons should service the system.

The installation and service of this unit is to be performed only by service personnel having appropriate training and experience. It is critical that installers have the necessary awareness about hazards to which they are exposed in performing a task, and of the measures required to minimize the danger to themselves or other persons.

Electrical shock hazards from the telecommunication network and AC mains are possible with this equipment. To minimize risk to service personnel and users, the ICS must be connected to an outlet with a third-wire ground. In addition, all unused slots should have filler faceplates installed and the doors should be in place at the completion of any servicing.

Service personnel must be alert to the possibility of high leakage currents becoming available on metal system surfaces during power line fault events near network lines. A risk point on the ICS is the power cord earth ground pin. These leakage currents normally safely flow to Protective Earth ground via the power cord. Therefore, it is mandatory that connection to a grounded outlet is performed first and removed last when cabling the unit. Specifically, operations requiring the unit to be powered down must have the network connections (central office lines) removed first.

Planning checklist

The following section provides a check list for the set up processes for the MICS system.

Hardware

- Verify that you have all the equipment and supplies you need to install the system. See *Required equipment* on page 179.
- Determine the location for the Integrated Communication System (ICS) and any expansion modules, telephones and other equipment.
- Install the ICS equipment. Refer to *Installation* on page 209.

Initial configuration

Turn on the equipment, and do the following procedures within 10 minutes. If you change the defaults, note the changes in the Programming record.

- Use the Profile code to access the profile interface if you require a profile that is different from the one used for North American systems. Refer to *Profile programming* on page 296.
- Use the Dialpad code to access the dialpad interface if your system uses the CCITT dialpad. Refer to *Dialpad programming* on page 300.
- Use the Startup code to access the template settings. If your system requires non-default template. Refer to *Performing Startup* on page 301.

System configuration

- Plan and record system programming details in the *Programming Record*.
- Use the System Administrator password to make any changes to the system defaults. Enter any information required for your system lines and telephones.

Required equipment

- Integrated Communication System (ICS)
- Modular ICS ROM software cartridge
- Modular ICS NVRAM cartridge
- Trunk Cartridge(s) for the ICS
- Services Cartridge — one required for T1, PRI or BRI, two required for busy sites
or a Combination Fiber 6-port Services Cartridge, which provides the same Services Cartridge functionality
- Digital Trunk Interface (DTI) configured for PRI
- BRI card(s) for the ICS, as required
- emergency telephones — two for ICS, one for each trunk module, as required
- Business Series Terminals or Norstar telephones
- ISDN devices, for example, ISDN equipment or data devices, as required
- distribution panel(s)

Expansion equipment

- Expansion Cartridge — two-port or six-port
- Combination Fiber 6-port Services Cartridge
- Trunk Module(s) (TM)
- Station Module(s) (SM)
- Trunk Cartridge(s) for the TM
- power bar



Your Norstar system requires connection to a grounded outlet.

To prevent possible injury from voltage on the telephone network, disconnect all central office and station lines before removing the plug from the electrical outlet.

The basic Integrated Communication System (ICS) supports up to 32 telephones. With the addition of Trunk Cartridges, you can connect up to 48 digital lines to the ICS.

With the addition of an Expansion Cartridge or a Combination Fiber 6-port Services Cartridge in the ICS, you can add Trunk Modules, Station Modules, Integrated Data Modules, or a combination of modules to increase your system capacity.

Installed in ICS	Additional modules allowed		
	Trunk	Station	Maximum
MICS 6.0 system No Expansion cartridge (mini)	0	0	0
2-port Expansion cartridge (midi)	2	2	2
6-port Expansion cartridge (maxi)	6	6	6
XC system Combination Fiber 6-port Services Cartridge (maxi)	6	6	6

Installed in ICS	Additional modules allowed		
	Trunk	Station	Maximum
Combination Fiber 6-port Services Cartridge and 6-port cartridges (mega)	6	12*	12
Two Combination Fiber 6-port Services Cartridge (mega)	6	12*	12

*The last two ports are reserved for Companion use and for data modules. See the *Modular ICS Companion Installer Guide* for more information about Companion programming.

Optional equipment

- station auxiliary power supply (SAPS)
- Busy Lamp Field (BLF) (for the M7310/T7316 telephone only)
- central answering position (CAP) module (for the M7324 telephone only)
- Analog Terminal Adapter (ATA or ATA2)
- external music source
- auxiliary ringer
- headset
- telephone loud ring amplifier
- base stations, handsets, antennas and remote power interconnect units
- uninterruptible power supply

If the system is equipped with digital lines, use an uninterruptible power supply so that the DTI keep-alive signal will continue to be sent to the network in the event of a power failure.

Equipment for installing the ICS and modules

- screwdriver
- pliers
- connecting tool (punch-down tool)
- four 19 mm (3/4 in.) wood screws for each of the mounting brackets
- 38 mm (1 1/2 in.) screws for the cable troughs (two screws for the ICS and SM, four screws for the TM)
- 19 mm (3/4 in.) thick wooden backboard

Location requirements

- minimum distance of 4 m (13 ft.) from equipment such as photocopiers, electrical motors, and other equipment that can produce electromagnetic, radio-frequency, or electrostatic interference
- clean, dry, and well-ventilated
- minimum clearance of 150 mm (5 in.) above and 100 mm (4 in.) below the ICS
- the gap between the ICS and the wall should be left completely clear to allow proper heat dissipation
- temperature between 0°C and 50°C (32°F and 122°F)
- humidity between 5% and 95%, non-condensing

Spacing requirements for a typical MICS-XC 6.0 system

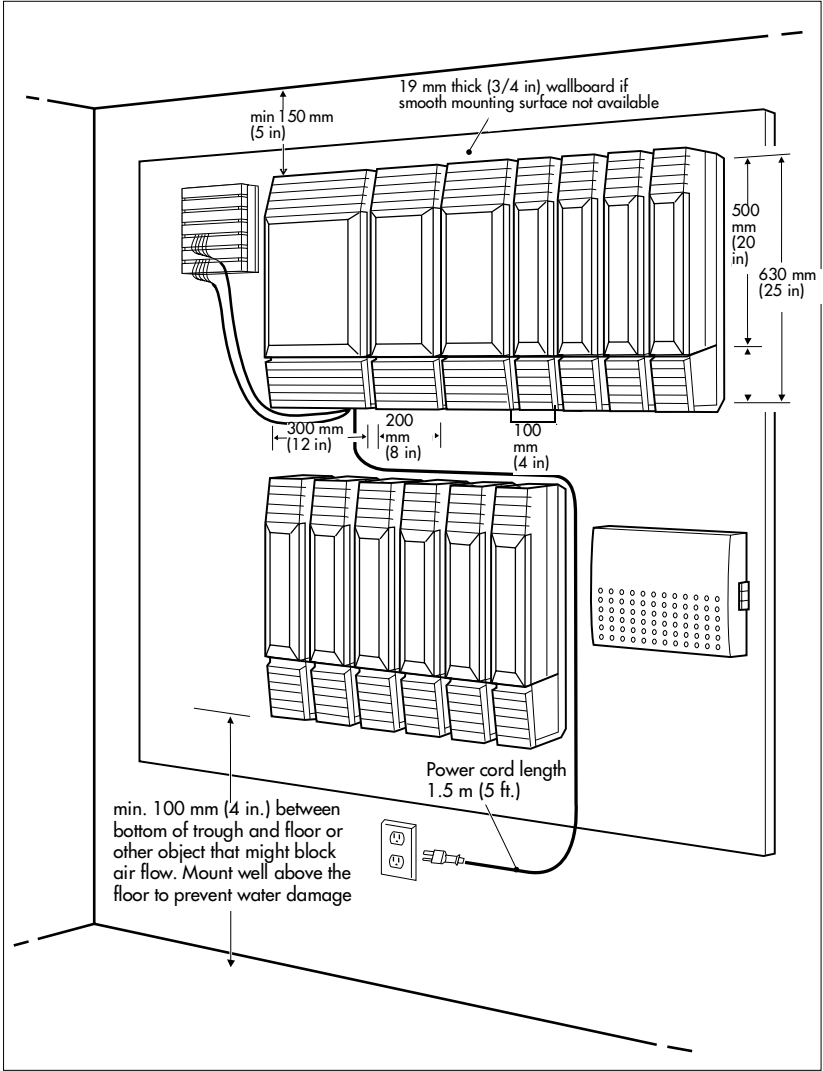

Electrical requirements

- non-switched outlet within 1.5 m (5 ft.) of the ICS
- The ICS and module power cords are 1.5 m (5 ft.) long. You may connect the ICS and modules to a power bar. The power bar must be CSA certified and UL listed with a third-wire ground.
Do not use an extension cord between the ICS and the power bar, or between the power bar and the electrical outlet.
- AC outlet equipped with a third wire safety ground to provide shock protection and avoid electromagnetic interference
- dedicated 110 V AC nominal, 50/60 Hz, 15 A minimum service with a third-wire safety ground



Risk of electric shock.

The safety of this product requires connection to an outlet with a third-wire ground. Use only with three-prong power cord and outlet.



Check ground connections.

Ensure that the electrical ground connections of the power utility, telephone lines and internal metallic water pipe system, if present, are connected together. If they are not connected together, contact the appropriate electrical inspection authority. Do not attempt to make the connections yourself.

Configuring Trunk Cartridges

If you plan to configure lines on a Loop Start Trunk Cartridge as auto-answer, you will need an E&M Trunk Cartridge for every two auto-answer loop start lines. The E&M Trunk Cartridge provides DTMF receivers for auto-answer loop start lines. You can install three additional Trunk Cartridges in each Trunk Module. The following table shows you the line capacity of each Trunk Cartridge.

Trunk Cartridge	Line capacity
DTI configured for T1 (ICS only)	24
DTI configured for PRI T1(ICS only)	23
DTI configured for ETSI PRI	30 (Profile 2)
BRI-ST & BRI-U4	8
BRI-U2	4
Loop Start with disconnect supervision	4
GATC/CI	4
DID (TM only)	4
E&M (TM only)	2

You can install different types of Trunk Cartridges together in the same Trunk Module. When mixing Trunk Cartridges, use a separate block on the distribution panel for each type of Trunk Cartridge.

Configuring Station Modules

Each Station Module allows you to connect up to 16 additional Norstar telephones to the system.

Mini	Midi		Maxi				Mega				Mega / Companion	
ICS	SM3	SM4	SM5	SM6	SM7	SM8	SM9	SM10	SM11	SM12	SM13	SM14
32	48	64	80	96	112	128	144	160	176	192	208	224



Tips - *The following combinations are not supported with the MICS 6.0 and MICS-XC 6.0 systems:*

- *two 2-port expansion cartridge system (four fiber ports total)*
- *a six-port and a two-port expansion combination (eight fiber ports total)*

In a fully expanded system using 48 digital channels, consider installing two service cartridge functionality to prevent blocking of incoming calls due to lack of DTMF resources.

Internal wiring requirements

The following section describes the cable required for the Norstar loop and an ISDN S reference point S loop.

Norstar loop

- one, two or three twisted pair cables per telephone
- dc loop resistance of less than 64 Ω
- cable length (0.5 mm or 24 AWG) less than 300 m (1000 ft.)

- use of a station auxiliary power supply (SAPS) for loops 300 m (1000 ft.) to 790 m (2600 ft.). The SAPS must be a Class 2 power source that is UL listed and CSA certified.
- no bridge taps

ISDN S reference point (S Loop)

- no longer than 1000 m (3,200 ft.) for point to point
- no longer than 450 m (1,475 ft.) on a point-to-multipoint extended passive bus
- no longer than 100 m (300 ft.) for 75 ohm cable or 200 m (600 ft.) for 150 ohm cable on a point-to-multipoint short passive bus

Wiring for the S reference point (S loop) should conform to ANSI T1.605. Wiring for the ISDN U reference point (U loop) should conform to ANSI T1.601.



Verify lightning protectors.

Check the lightning protectors at the cable entry point to the building with special attention to the grounding. Report any problems to the telephone company in writing.

Equipment that is designed to be connected using internal wiring is typically not lightning protected. Norstar telephone equipment and ISDN S loops and T loops should not leave the building where the ICS is installed.

System overview

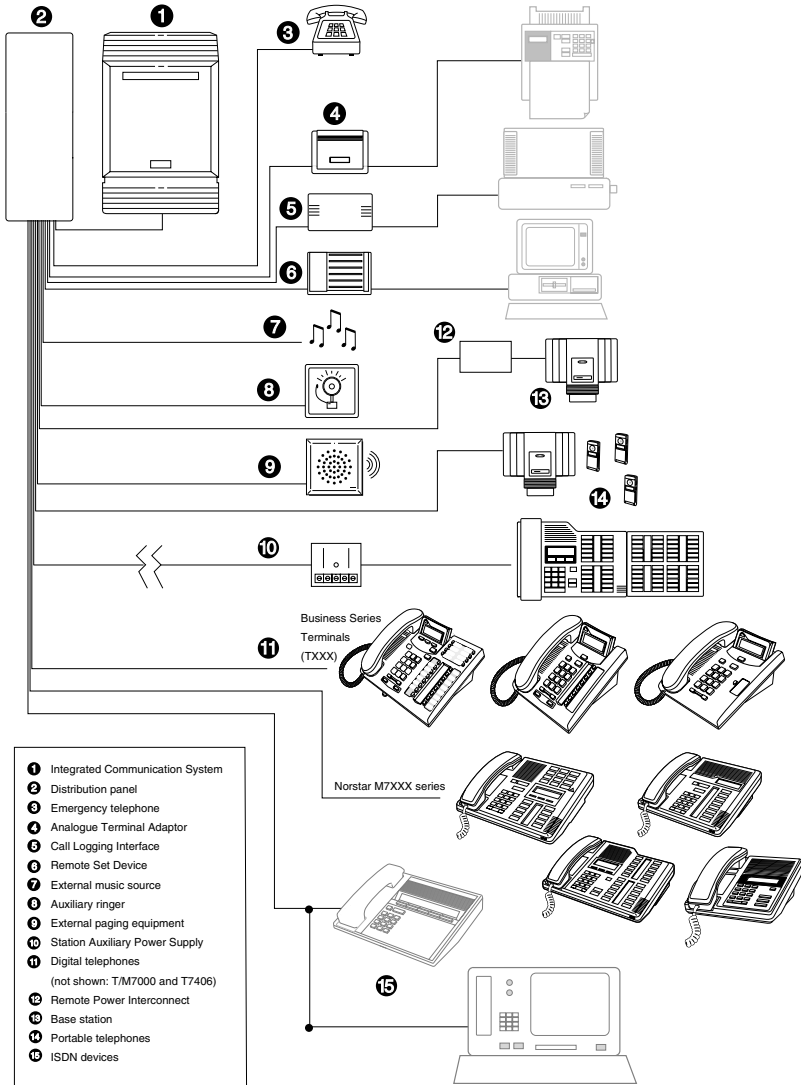

Upgrading your Norstar system

What procedure you use to upgrade your Norstar system will depend on what version of MICS software you are upgrading to.

Upgrade notes:

- When making simultaneous hardware and software upgrades (e.g. 12-port expansion plus a MICS 6.0 software upgrade), upgrade your software release before making your hardware upgrades.
- Ensure you power up the system after the new software has been installed, but before any new hardware is added. Upgrading in this order maintains your 0X32 ICS programming data for use with MICS 6.0 and MICS-XC 6.0.

Upgrade from 4.0, 4.1 or 5.0 to 6.0

Your MICS 6.0 upgrade includes a modular CS ROM cartridge that contains the new software.

To upgrade from a MICS 5.0 system:

1. Power down.
2. Disconnect all amphenol cables.
3. Remove the power to the ICS and all associated modules. Disconnecting the power ensures protection for electronic components and that the data stored in the feature cartridge will not be corrupted.
4. Remove the MICS (4.0, 4.1 or 5.0) CS ROM cartridge.

Note: Your system information remains on the NVRAM unit that the CS ROM cartridge fits into.

5. Insert the new MICS 6.0 CS ROM cartridge.
6. Plug the ICS back into the power source.
7. Reconnect all amphenol cables.
8. Wait for the system to reboot.

Upgrade from 4.0/4.1 to 5.0

Your MICS 5.0 upgrade includes a modular CS ROM cartridge that contains the new software.

To upgrade from a MICS 4.0 or MICS 4.1 system:

1. Power down.
2. Disconnect all amphenol cables.
3. Remove the power to the ICS and all associated modules. Disconnecting the power ensures protection for electronic components and that the data stored in the feature cartridge will not be corrupted.
4. Remove the MICS 4.0 or MICS 4.1 CS ROM cartridge.

Note: Your system information remains on the NVRAM unit that the CS ROM cartridge fits into.

5. Insert the new MICS 5.0 CS ROM cartridge.
6. Plug the ICS back into the power source.
7. Reconnect all amphenol cables.
8. Wait for the system to reboot.

Upgrade from pre-4.0 system to 6.0, (reprogramming may be required)

If you want to upgrade from a pre-4.0 system, you need both a MICS Non Volatile Read-only Memory (NVRAM) cartridge with a MICS 6.0 CS ROM cartridge installed.

Note: This upgrade may require some partial reprogramming.

To upgrade the software, follow these steps:

1. Power down.
2. Disconnect all amphenol cables.
3. Remove the power to the ICS and all associated modules. Disconnecting the power ensures protection for electronic components and that the data stored in the feature cartridge will not be corrupted.
4. Remove the entire cartridge.
5. Insert the new NVRAM cartridge with the Upgrade CS ROM software.
6. Plug the ICS back into the power source.
7. Reconnect all amphenol cables.
8. Wait for the system to reboot.
9. Repeat steps 1 to 3.
10. Remove the upgrade cartridge and insert the MICS 6.0 CS ROM cartridge.
11. Repeat steps 6 to 8.
12. Run the profile, dialpad, and startup programming within 15 minutes after reboot.
13. Program the system to your requirements.

About the MICS NVRAM cartridge



Do not install a MICS NVRAM cartridge from other MICS 6.0 systems. This will cause all the programming to be lost.

Do not attempt to use the MICS NVRAM cartridge as stored data transfer. This will cause the system to cold start.

The NVRAM assembly cartridge has a slot for a credit-card size PC-card, which are also referred to as Flash cards. These cards contain the system software and accommodate future system memory requirements and software downloading.

Supported upgrades in MICS 6.0

Upgrading from...	Target Upgrade		
	MICS 6.0	USA-MICS-XC 6.0	CDA-MICS-XC 6.0
MICS (all versions) 1.0-3.0	If you upgrade from software versions prior to MICS 4.0, some partial reprogramming may be required. An alternative upgrade, to retain programming integrity, is to upgrade to version 4.0, 4.1, or 5.0 and then upgrade to 6.0. Refer to <i>Upgrade from pre-4.0 system to 4.0, 4.1 or 5.0 (retain programming)</i> on page 193.		
MICS 4.0	Insert MICS CS ROM cartridge with appropriate software load.		
USA-MICS-XC 4.0	Insert MICS CS ROM cartridge with appropriate software load.		
CDA-MICS-XC 4.0	Insert MICS CS ROM cartridge with appropriate software load.		

Upgrading from...	Target Upgrade		
	MICS 6.0	USA-MICS-XC 6.0	CDA-MICS-XC 6.0
MICS 4.1	Insert MICS CS ROM cartridge with appropriate software load.		
USA-MICS-XC 4.1	Insert MICS CS ROM cartridge with appropriate software load.		
CDA-MICS-XC 4.1	Insert MICS CS ROM cartridge with appropriate software load.		
MICS 5.0	Insert MICS CS ROM cartridge with appropriate software load.		
USA-MICS-XC 5.0	Insert MICS CS ROM cartridge with appropriate software load.		
CDA-MICS-XC 5.0	Insert MICS CS ROM cartridge with appropriate software load.		

Upgrade from pre-4.0 system to 4.0, 4.1 or 5.0 (retain programming)

If you want to perform a two-step upgrade from a pre-4.0 system, so you can retain your system information, you need to use the upgrade tool that was introduced with MICS 4.0 and either the 4.0, 4.1 or 5.0 software upgrade. The upgrade tool allows you to transfer your NVRAM information to the new style NVRAM cartridge that contains a MICS CS ROM cartridge.

If you do not use the upgrade tool, all or part of your programming will be lost.

To use the Upgrade Tool to upgrade from previous versions of MICS (all versions prior to MICS 4.0), follow these steps:

1. Power down.
2. Disconnect all amphenol cables.
3. Remove the power to the ICS and all associated modules. Disconnecting the power ensures protection for electronic components and that the data stored in the feature cartridge will not be corrupted.
4. Remove your old Norstar MICS software cartridge.
5. This step determines the type of MICS system you will ultimately upgrade to.

Insert the MICS NVRAM cartridge. See illustration on page 219.

Insert the PC-card (or Flash card) that came with your upgrade tool package.



Ensure that you use the appropriate MICS upgrade tool when upgrading.

Your Norstar system will cold start and your data will be lost if the MICS ROM software cartridge that came in your upgrade tool does not match your MICS system software.

6. Reconnect all amphenol cables.
7. Power up. Wait until display flashing stops. **Insert MICS Card** is displayed.
8. Power down.
9. Insert the Modular ICS ROM software cartridge to perform the final stage of the upgrade to MICS 4.0, 4.1, or 5.0. See *Installing the ROM Software Cartridge* on page 219 to verify that you are using the proper software cartridge.
10. Power up.

If no alarm-event messages are observed, the upgrade to the new MICS software has been performed.

If alarm codes are displayed, refer to *Alarm codes* on page 506 for definitions.

If event messages are displayed refer to *Event messages* on page 514 for definitions.

11. Once you confirm your system information, you can choose to upgrade to the MICs 6.0 software. Refer to *Upgrade from 4.0, 4.1 or 5.0 to 6.0* on page 189.

Notes



All old programming is maintained when upgrading from the 0X32 Release 1 - T1 software, with the following exceptions:

- all system passwords are returned to the system defaults
- ATA ans timer setting is returned to the system default setting

Ensure that you maintain an accurate record of your existing system programming so that you can plan your new system programming appropriately.



When upgrading from MICS 1.1, note that the Call log space has increased in newer versions.

Reallocate log space after upgrading.

If you have a Norstar system with a Modular 8X24 Key Service Unit (KSU), you cannot upgrade your software with the Upgrade Tool. If you want to upgrade to MICS 6.0, you

must replace your older Modular 8X24 KSU with the current 0X32 ICS, and then program the system.

Note: The Key Service Unit (KSU) has been renamed the Integrated Communication System (ICS).

If you have a Norstar system with a Modular 0X32 ICS, you can use your ICS with the new MICS 6.0 and MICS-XC 6.0 software.



When upgrading, Call Log information may be lost.

During a system restart, Call Log information is not saved. Make sure to notify users if a system restart is planned so any log information can be recorded first.



A loss of UTAM information occurs when upgrading US MICS-XC systems.

UTAM Recovery Codes are required. If you are upgrading the system to include Companion components, see the upgrade instructions included in the *Modular ICS Companion Installer Guide*.

Upgrading from MICS 6.0 to MICS-XC 6.0

MICS 6.0 mini to XC 6.0 mini

1. Install XC 6.0 ROM software cartridge.
2. Use module 1 (ports 101 to 132) for telephones only and module 2 for Trunk Cartridges only.

MICS 6.0 mini to XC 6.0 midi

1. Install XC 6.0 ROM software cartridge.
2. Install two-port Expansion Cartridge in slot 2.
3. Connect trunk modules beginning at port 4 and station modules beginning at port 3.

MICS 6.0 mini to XC 6.0 maxi

1. Install XC 6.0 ROM software cartridge.
2. Install a Combination Fiber 6-port Services Cartridge in slot 2.
3. Connect trunk modules beginning at port 8 and work down and station modules beginning at port 3 and work up.

MICS 6.0 midi to XC 6.0 midi

1. Install XC 6.0 ROM software cartridge.

MICS 6.0 midi to XC 6.0 maxi

1. Install XC 6.0 ROM software cartridge.
2. Replace two-port Expansion Cartridge with either a Combination Fiber 6-port Services Cartridge or a 6-port Fiber Expansion Cartridge in ICS slot 2.
3. Connect trunk modules beginning at port 8 and work down and station modules beginning at port 3 and work up. Refer to page 216.

MICS 6.0 maxi to XC 6.0 maxi

Install XC 6.0 ROM software cartridge.

MICS 6.0 maxi to XC 6.0 mega

1. Install XC 6.0 ROM software cartridge.
2. Replace two-port Expansion Cartridge with two Combination 6-port fiber Expansion Cartridges or one 6-port Fiber Expansion Cartridge and one Combination Fiber 6-port Services Cartridge in ICS slots 1 and 2.
3. Connect trunk modules beginning at port 8 and work down.
4. Connect station modules beginning at port 3 and work up.



Tips - *Trunk modules cannot be connected to the Combination Fiber 6-port Services Cartridge in slot 1. (fiber interface ports 9 through 14).*

To add Station Modules to ports 13 and 14 in a mega system refer to Modular ICS Companion Installer Guide.

Slots on ICS

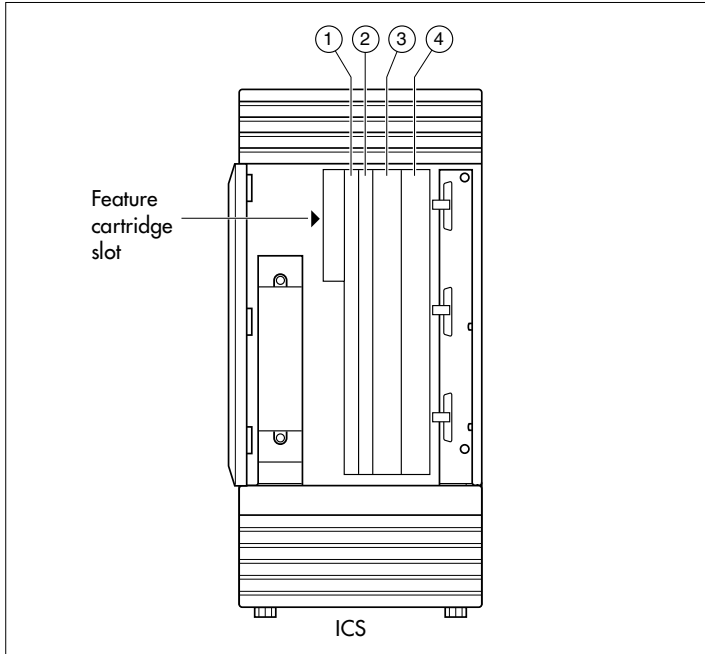

Trunk and Station Modules

If you are not adding digital T1 trunks to your system, or expanding to a mega configuration, you may reuse your existing copper Trunk and/or Station Modules with the Modular 0X32 ICS in MICS 6.0/XC 6.0. One 6-port copper expansion cartridge can be supported on the maxi configuration.

If you are adding digital T1 trunks to your system or expanding to a mega configuration, you must replace any copper Trunk and/or Station Modules with the new modules that have fiber connectors, and use a new fiber Expansion Cartridge in the ICS. You can reuse your old Trunk Cartridges in the new Trunk Module with fiber connectors.

Trunk modules cannot be installed on the second expansion (6-port) cartridge. You must relocate station modules to the second expansion cartridge to free up ports on the first 6-port expansion cartridge.

Global Analog Trunk Cartridge/CLI Cartridge

These cartridges have dip switches that may need to be set if your system is not running with the North American profile (Profile 1). Set the dip switches before you install the cartridge.

GATC dip switch settings (default is North America)(

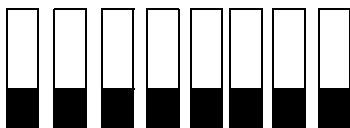

The following table lists the various dip switch settings. However, for this release, only the North America, Taiwan, and Australia settings are active.

DIP switch setting	Country profile
00000000	North America
10000000	Taiwan
01000000	Australia
11000000	*Chili
00100000	*Peru
10100000	*Argentina
01100000	*Mexico
11100000	*Sweden
00010000	*South America
10010000	*Brazil
01010000	*Norway
11010000	*France
00110000	*Germany

DIP switch setting	Country profile
10110000	*Korea
XXXXXXXX1	*Reserved
XXXXXXXX1X	*Reserved
XXXXX1XX	*Reserved
* Reserved for future development	

Off-core DTI card

MICS 6.0 provides the opportunity to expand the number of DTI cards in your system by adding a DTI card to the expansion modules in a midi or maxi system. The card must be installed in either module 3 or 4 on a midi system. On the maxi system, the card can only be installed in module 7 or 8. One DTI card requires the entire module resources, so it is installed in the first slot of the module, and the other two slots must be left empty. The off-core DTI is configured in the same way as the other DTIs on your system.

This card is supported for profiles 1 and 4.

Equipment note: The DTI card released in conjunction with MICs 6.0 can be used either on or off-core. However, any previous versions of the DTI card can only be used on the core KSU hardware.

Replacing a Modular 8x24 KSU

If you are upgrading your old KSU (8X24) and adding digital T1 trunks to your new system (0X32 ICS):

1. Verify your system programming, and update your *Programming Record*.
2. Follow the procedures outlined in *Installation* on page 209 for installing a new system.

If you are upgrading your 8X24 KSU, but not adding digital T1 trunks to a 0X32 system:

1. Verify your system programming, and update your *Programming Record*.
2. Disconnect the 50-pin connector for telephones from the KSU.
3. Disconnect the 50-pin connector for external lines and auxiliary equipment from the KSU.
4. Remove power from your system.
5. If your system includes Trunk Modules and Station Modules with DS-30 copper connectors, disconnect the DS-30 copper connectors from the Expansion Cartridge.
6. Remove any cables from the KSU cable trough.
7. Remove the KSU and wall-mount bracket from the wall.
8. Install the new 0X32 ICS following the procedures in the *Installation* on page 209.
9. If your system includes Trunk Modules and or Station Modules with DS-30 copper connectors, install a compatible Expansion Cartridge with copper connectors in slot 1 of the ICS. The faceplate will cover slots 1 and 2.



Do not reuse 8X24 Expansion Cartridge

You cannot reuse an 8X24 Expansion Cartridge in the 0X32 ICS. You must install a supported Expansion Cartridge.

10. If you have installed a copper Expansion Cartridge in the 0X32 ICS, clip the ferrite bead that was shipped with the Expansion Cartridge onto the ICS power supply power cord.

Locating the ferrite bead

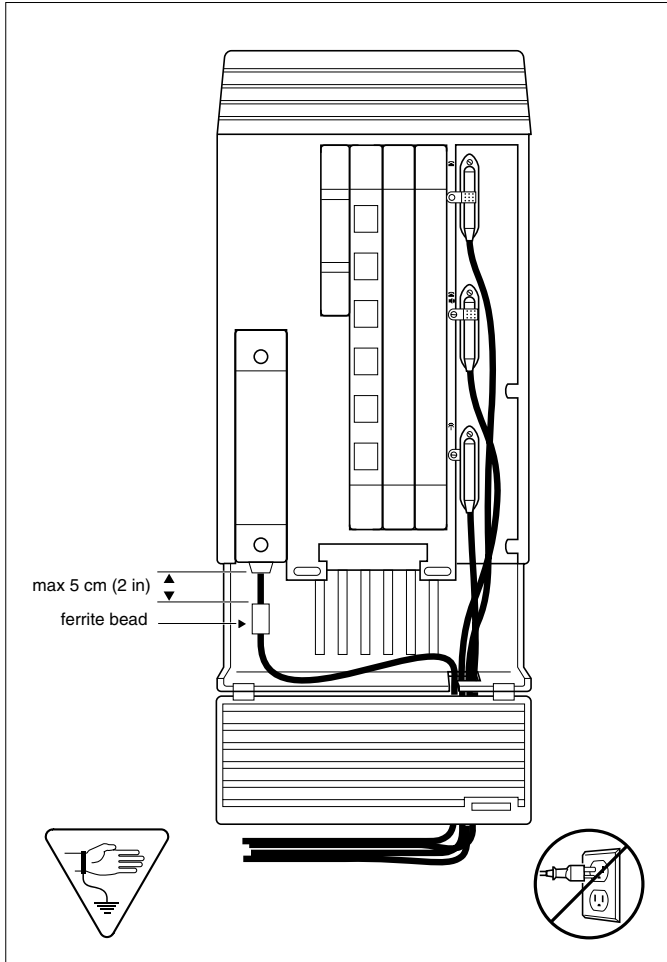

Ferrite bead required to meet EMI requirements

When using a copper Expansion Cartridge, you must install the ferrite bead on the ICS power cord to ensure that the product continues to meet FCC Part 15 Class A EMI requirements.

11. If your system includes Trunk Modules and or Station Modules with DS-30 copper connectors, reconnect the fiber interface cables to the Expansion Cartridge.
12. Power up the system.
13. Reconnect your 50-pin connector for internal telephones to the internal telephone connector on the ICS.
14. Reconnect your external line and auxiliary equipment wiring according to the procedures and wiring charts in the *Installation* on page 209. You cannot reuse your original 50-pin connector for external lines and auxiliary equipment, because the pin-outs have changed (unless connections are rewired).



DNs on Station Modules will change

If you simply reconnect the 50-pin connector for telephones on the ICS, and leave your Station Modules telephone connectors alone, your directory numbers will change.

The new 0X32 ICS can accommodate 32 telephones. The old 8X24 KSU connected only 24 telephones. Port numbering has been changed accordingly.

To preserve existing directory numbers consult the wiring charts in *Connecting the wiring* on page 237 and change the DNs using *Change DNs* in *System Programming*.

Trunk module line numbering

In MICS 6.0/MICS-XC 6.0 software, the line numbering for all profiles has been adjusted to accommodate the Profile 2 ETSI requirement of 30 lines. This could affect applications such as Norstar Voice Mail or CallPilot 150. The chart below shows the line numbering transitions between the various versions of software. Note also that target lines have been renumbered.

Note: MICS 6.0 line numbering varies, depending on the profile you choose for your system, and which type of trunk module you are using, or what protocol you choose for the module (DTI). Refer to *TrunkMod* on page 467.

Line numbering for upgrades

Module	Cartridge	MICS 1.0 and 1.1 lines	MICS 2.0, 3.0, 4.0, and 5.0 lines	MICS 6.0 lines
Mod 08	Cd1-Mod8	49-52	49-56	61-68
	Cd2-Mod8	53-56	57-64	69-76
	Cd3-Mod8	57-60	65-72	77-84
Mod 07	Cd1-Mod7	61-64	73-80	85-92
	Cd2-Mod7	65-68	81-88	93-100
	Cd3-Mod7	69-72	89-96	101-108
Mod 06	Cd1-Mod6	73-76	97-100	109-112
	Cd2-Mod6	77-80	101-104	113-116
	Cd3-Mod6	81-84	105-108	117-120
Mod 05	Cd1-Mod5	85-88	109-112	121-124
	Cd2-Mod5	89-92	113-116	125-128
	Cd3-Mod5	93-96	117-120	129-132

Module	Cartridge	MICS 1.0 and 1.1 lines	MICS 2.0, 3.0, 4.0, and 5.0 lines	MICS 6.0 lines
Mod 04	Cd1-Mod4	97-100	121-124	133-136
	Cd2-Mod4	101-104	125-128	137-140
	Cd3-Mod4	105-108	129-132	141-144
Mod 03	Cd1-Mod3	109-112	133-136	145-148
	Cd2-Mod3	113-116	137-140	149-152
	Cd3-Mod3	117-120	141-144	153-156
Target lines			145-272 145-336 (expanded)	157-284 157-348 (expanded)

Upgrading ILG functionality with hunt groups

In MICS 4.0, Hunt groups replaced ILG functions from previous versions of MICS. The hunt group broadcast mode contains the equivalent of ILG functionality.

Hunt groups allow the following call programming:

- calls can be queued when all the members in a hunt group are busy
- call forwards are overridden by the hunt group routing, allowing calls to be distributed to other members in the hunt group in a way that does not depend on the busy situation of its members
- the ring / call distribution pattern can be programmed to determine who receives what call and in what order
- an overflow position can be programmed to another hunt group
- sequential and rotary modes are also available to provide versatility to hunt group configurations

For more information on hunt groups, see *System programming* on page 389.

Planning Hospitality functions

MICS 4.1 introduced the Hospitality feature, which allows businesses such as hotels to monitor and set room conditions and status, and to program alarms from both an administrative telephone and individual room telephones.

Hospitality features allow the following programming:

- Administrative telephone (password access)
 - monitor and set room condition
 - monitor and set room occupancy
 - monitor and set or cancel alarms
- Room telephone
 - Allow staff to set room condition (password access)
 - Allow guests to set or cancel wakeup alarms



Only qualified persons should service the system.

The installation and service of this unit is to be performed only by service personnel having appropriate training and experience. It is critical that installers have the necessary awareness about hazards to which they are exposed in performing a task, and of the measures required to minimize the danger to themselves or other persons.

Electrical shock hazards from the telecommunication network and AC mains are possible with this equipment. To minimize risk to service personnel and users, the ICS must be connected to an outlet with a third-wire ground. In addition, all unused slots should have filler faceplates installed and the doors should be in place at the completion of any servicing.

Service personnel must be alert to the possibility of high leakage currents becoming available on metal system surfaces during power line fault events near network lines. A risk point on the ICS is the power cord earth ground pin. These leakage currents normally safely flow to Protective Earth ground via the power cord.

Therefore, it is mandatory that connection to a grounded outlet is performed first and removed last when cabling to the unit. Specifically, operations requiring the unit to be powered down must have the network connections (central office lines) removed first.

Installation checklist

- test all ISDN network connections, if any
- mount the Integrated Communications System (ICS)
- mount the expansion modules (as required)
- install the Modular ICS NVRAM cartridge
- install the Expansion Cartridge, Trunk Cartridges (DTI, PRI, or BRI cards, as required)
- install the optional equipment
- install power bars, as required
- mount the distribution panel
- complete the wiring
- install the fiber cables
- install the emergency telephone(s)
- install the Norstar telephones
- power up the system
- connect the cables between the distribution block and the expansion modules
- install the door
- select the default template using System Startup programming
- program to customer requirements
- record programming details in the *Programming Record*
- ensure that all telephone keys are properly labelled
- ensure that all telephones are working
- check that the system is working properly

- ensure that all relevant documentation is left with the person in charge of the system
- train the Administrator using the *Getting Started* section in the *Modular ICS 6.0 System Coordinator Guide*
- for information on upgrading your ICS without adding digital T1, see *Trunk and Station Modules* on page 199.



To avoid electrical shock hazard to personnel or equipment damage, observe the following precautions when installing telephone equipment.

- Always disconnect telecommunication network connectors before disconnecting the AC power plug.
- Never connect the central office connectors until you have connected the power plug.
- Never install telephone wiring during a lightning storm.
- Never install telephone jacks in wet locations unless the jack is specifically designed for wet locations.
- Never touch non-insulated telephone wires or terminals unless the telephone line has been disconnected at the network interface.
- Use caution when modifying or installing telephone lines.

Testing the ISDN BRI network connection

Before you install a Norstar system which uses BRI cards you should test your connection to the ISDN network.

If you are installing a system which connects to the network using BRI-ST cards, the network connection must be equipped with an NT1. See the ISDN chapter and the wiring information in this chapter for more information about installing an NT1.

To test the ISDN BRI connection:

1. Connect ISDN terminal equipment (TE) that conforms to Bellcore standard to your central office ISDN jack or NT1. U interface TE can connect directly to the central office jack. S interface TE connect to the central office through an NT1.
2. Program the TE with the appropriate switch type, service profile identifier (SPID), and Network directory number (DN) using the instructions that come with the TE.
3. Check for dial tone, then place a call and verify the quality and clarity of the connection. If there is a problem, contact your service provider.
4. Repeat steps one through three for each network connection.

Installing the cartridges

The following table shows you which cartridges can be installed in which ICS and TM slots.

Cartridge type	ICS Slot	TM Slot
Modular ICS NVRAM cartridge	Feature Cartridge Slot	
Modular ICS ROM software cartridges: USA-MICS-XC 6.0 CDA-MICS-XC 6.0 NA-MICS 6.0	NVRAM Cartridge Slot	
Services Cartridge	1	
Fiber Expansion Cartridge (2-port)	2	
Fiber Expansion Cartridge (6-port)	1 or 2 (see note below)	
Combination Fiber 6-port Services Cartridge	1 or 2 (see note below)	
Digital Trunk Interface (DTI) card configured for T1 card or PRI	3 or 4	
MICS 6.0: Global Analog LS/DS trunk cartridge replaces: Loop Start Disconnect Supervision (LS/DS) Trunk Cartridge	3 or 4	1, 2 or 3
MICS 6.0: Global Analog CLI trunk cartridge replaces: Caller Identification (CI) Trunk Cartridge	3 or 4	1, 2 or 3
E&M Trunk Cartridge		1, 2 or 3
DID Trunk Cartridge		1, 2 or 3
Copper Expansion (2-port)	1	
Copper Expansion (6-port)	1	
BRI-ST card	3 or 4	1, 2 or 3
BRI-U2 card	3 or 4	1, 2 or 3
BRI-U4 card	3 or 4	1, 2 or 3

Note: Use Slot 1 only when installing cartridges for 12-port, fully expanded systems. In this case, both slots 1 and 2 are installed with 6-port Expansion or a Combination Fiber 6-port Services Cartridge. If you use both slot 1 and 2, the software must be MICS-XC.

- LS/DS Global Analog Trunk Cartridges and CI Global Analog Trunk Cartridges both support loop start external lines.
- The Digital trunk Interface (DTI) supports both digital T1 and PRI lines. The DTI card can be configured to support ISDN PRI
- The Loop Start Trunk Cartridge supports loop start external lines.
- The E&M Trunk Cartridge supports E&M lines and provides direct inward system access (DISA).
- The DID Trunk Cartridge supports direct inward dialing lines.
- The BRI-ST card supports ISDN BRI S or T reference point loops.
- The BRI-U2 and BRI-U4 cards support two or four ISDN BRI U reference point loops, respectively.
- The (AEM), also known as an Analog Station Module (ASM), connects up to eight standard through a fibre cable link.

Mounting the modules

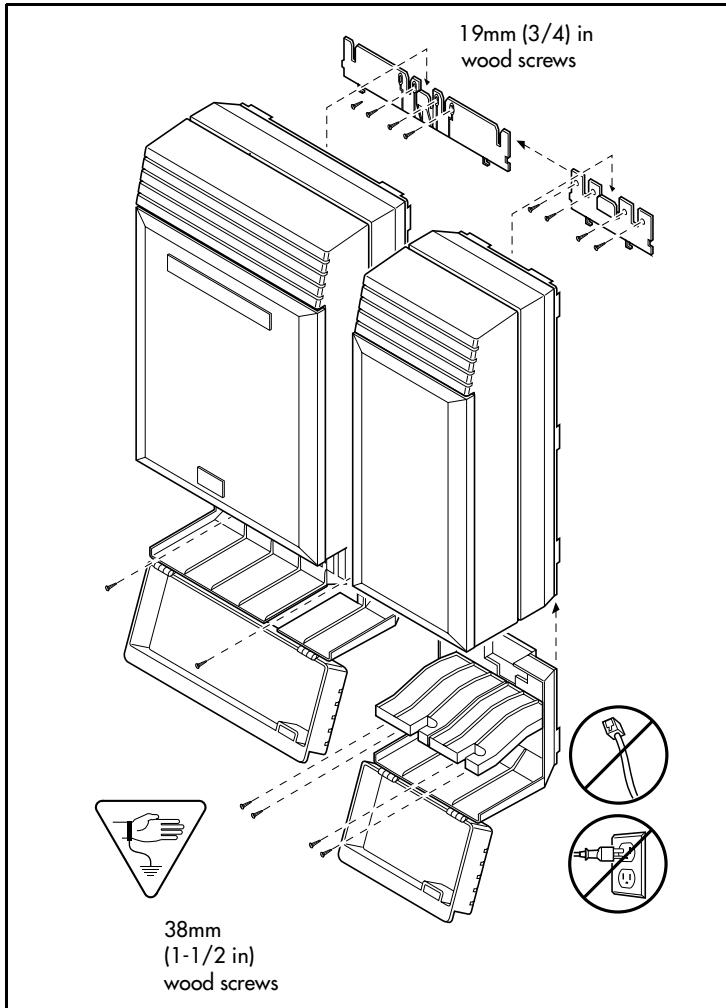

Attach bracket to secure surface.

Do not screw bracket directly to drywall. Use the two inner screw holes on the bracket.

1. Secure a 19 mm wood backboard to a wall. It must be capable of supporting a 20 kg mass.
2. Position the module mounting bracket on the backboard, smooth side against the backboard, with the screw holes at the top. Ensure that the bracket is level.
3. Fasten the bracket to the backboard with two 3/4-inch No. 10 round head wood screws through the inner pair of holes. The other two holes are optional.
4. Slide the module down onto the center bracket flange. Line up the notches on the far side of the bracket to the flanges on the module.
5. Open the front cable trough door. Fasten the bottom of the module to the backboard. Use two 3/4-inch No. 10 round head wood screws through the screw holes on each side of the cable trough.

See *T1 or ISDN-PRI configurations* on page 482 for configurations of Trunk Cartridges on the ICS slots.

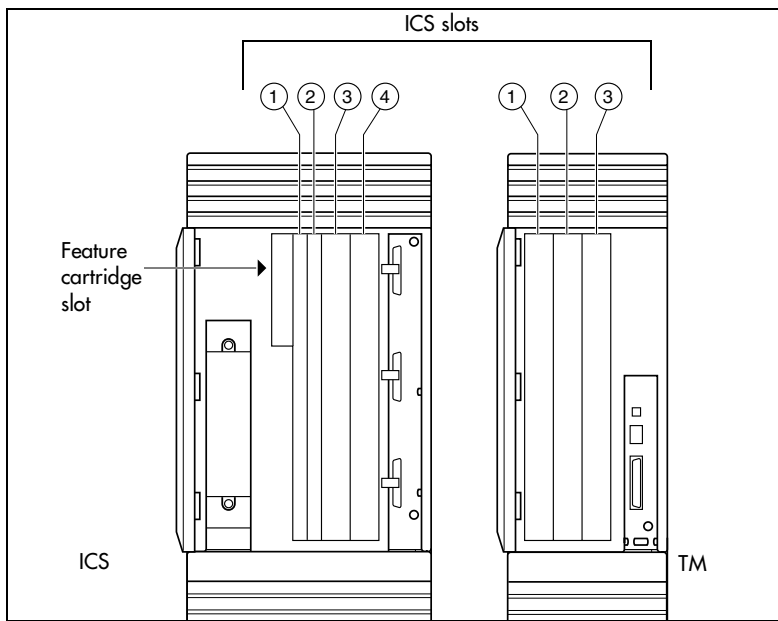

**Avoid risk of electrical shock.**

Voltages of up to 130 V may be present on the 1.544 Mbps circuit and on portions of the DTI circuitry.

Installation tips

- For a two-port (midi) system, a two-port fiber Expansion Cartridge is installed only in ICS slot 2.
- For a six-port (maxi) system, a six-port fiber Expansion Cartridge or a Combination Fiber six-port Services Cartridge is installed only in ICS slot 2.
- When a six-port fiber Expansion Cartridge is installed in ICS slot 2, either an additional six-port fiber Expansion Cartridge, for a fully analog trunk system, or a Combination Fiber 6-port Services Cartridge, can be installed in ICS slot 1 for a 12-port (mega) system with digital or BRI lines.
- Two Combination Fiber 6-port Services Cartridge are supported on a mega configuration using both ICS slots 1 and 2. When expanding beyond 6 ports, it is recommended two Combination Fiber 6-port Services Cartridge be used if two DTI cards are installed.
- For a 12-port (mega) system, any combination of the 6-port fiber Expansion and the Combination Fiber 6-port Services Cartridge is supported using both ICS slots 1 and 2.
- A copper Expansion Cartridge is a full-width cartridge and covers both ICS slots 1 and 2.
- One 6-port copper Expansion Cartridge is supported for a maxi configuration and can only be installed in slot 1.

- One two-port copper Expansion Cartridge is supported for a midi configuration and can only be installed in slot 1.
- Depending on your system configuration, BRI-ST, BRI-U2, BRI-U4, the off-core DTI cards can only reside in certain trunk modules. In a midi system, the cards must be in trunk modules 3 or 4, for a maxi or mega system, the cards must be in trunk modules 7 or 8. The cards can reside in the ICS regardless of system size.



Alarm Telephone will indicate a warm or cold reset.

An alarm and a prompt indicating warm or cold reset will occur on the alarm telephone if an expansion cartridge is installed in the wrong ICS slot or when the system size has been decreased.

Installing the ROM Software Cartridge

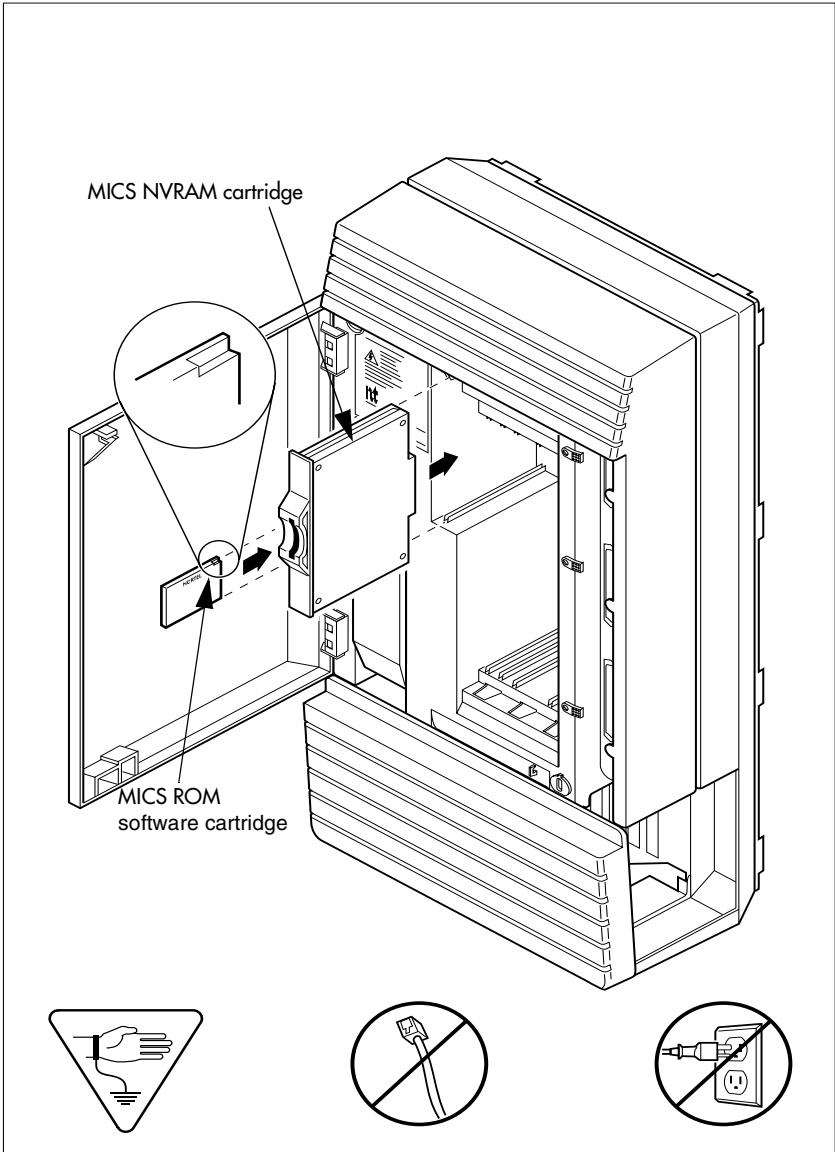

MICS ROM software cartridge

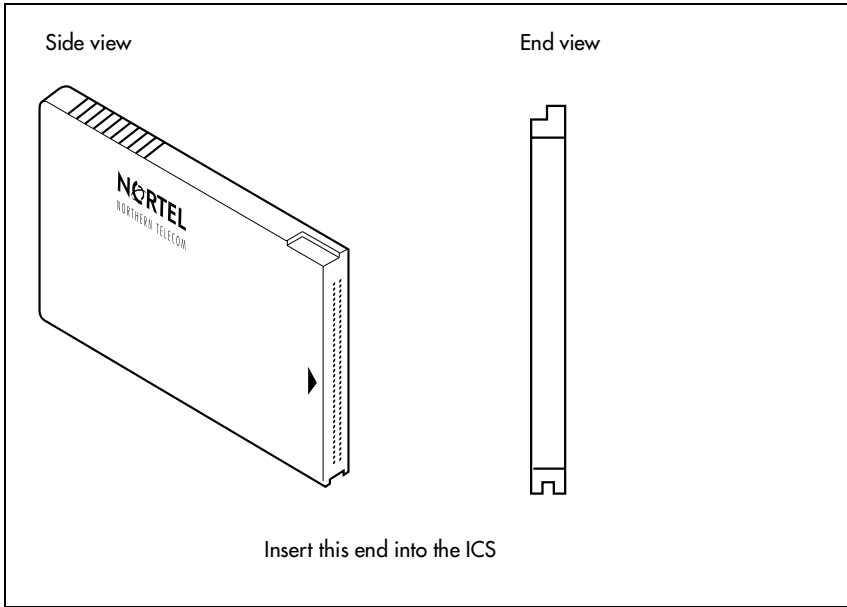

Inserting a cartridge

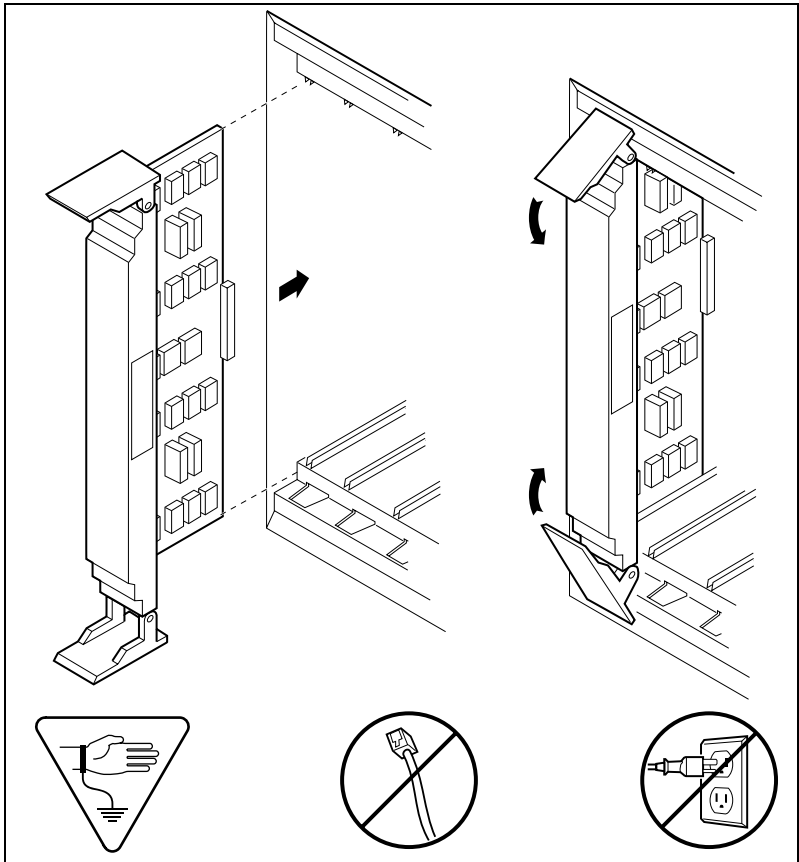

Close clips simultaneously.



It is important to center and close the two clips on the cartridge simultaneously. The cartridge may become misaligned in its slot or with its connector. If improperly inserted, the connector will be damaged.

PCB is electrostatic-sensitive.



Do not touch the printed circuit board on a cartridge. This is an electrostatic-sensitive device.

1. Install trunk cartridges in the ICS beginning with Slot 4 then Slot 3.
2. Install trunk cartridges in the trunk modules beginning with Slot 1 then Slot 2 and then Slot 3.

For easier wiring, install similar type Trunk Cartridges together in the same Trunk Module.

If you install an E&M or a DID or BRI Trunk Cartridge in the left-most slot (slot 1) of a TM, emergency telephones cannot be supported for that Trunk Module.

Terminating resistors on BRI-ST Cards

The standard ISDN user-network interface wiring requires terminating resistors at each end of the loop for point-to-point operation. This ensures correct timing of the signaling circuits.

Loop termination can be provided at either the point where the ISDN terminal is attached, or by the device attached to the loop which has built-in termination. Because the Modular ICS is usually at one end of the loop, the BRI-ST card is shipped with termination built-in for each ISDN loop. It is ready to be used where the ICS is located at one end of the loop, as in the following illustration:

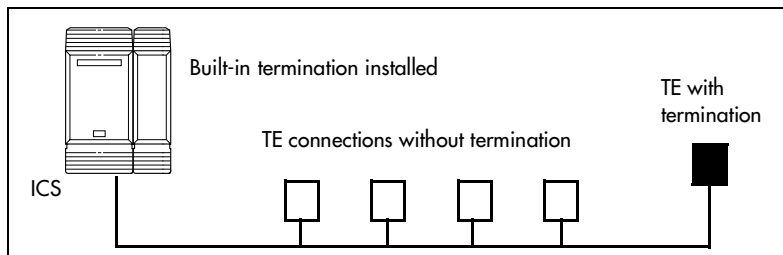

Shorting straps on a BRI-ST card

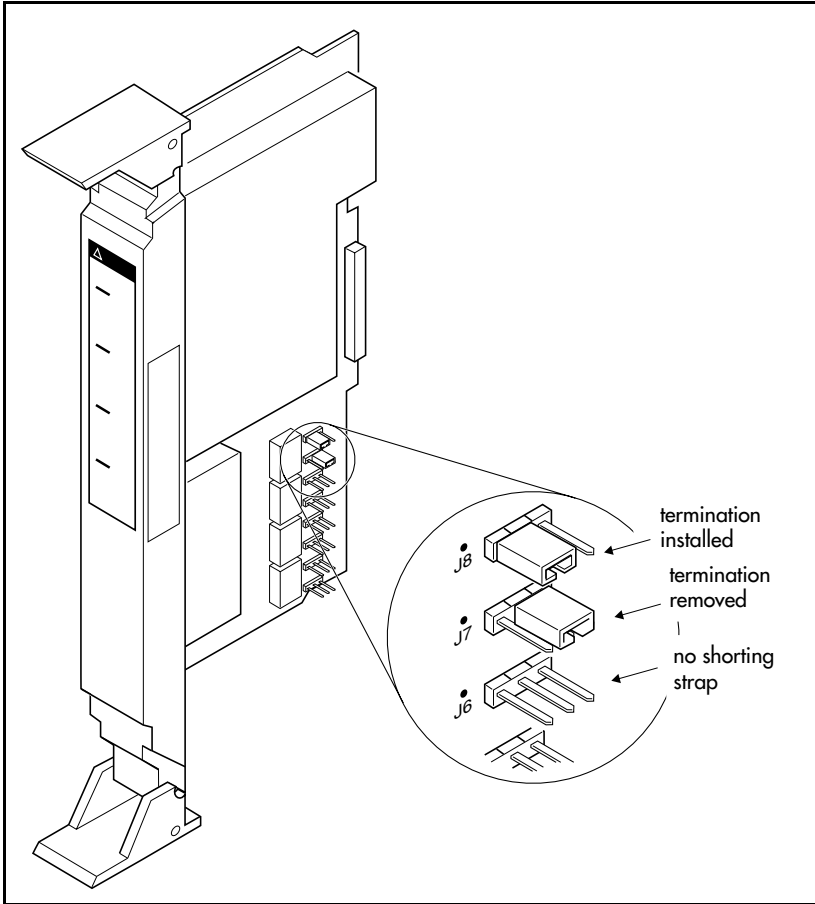

Ensure that the shorting straps are installed on both the receive and transmit jumpers for the loop. Refer to the illustration above.

The jumpers are numbered top to bottom, but the loops associated with each pair of jumpers does not follow the same top-to-bottom sequence. Refer to the table on the next page.

Receive and transmit jumper loop connections

Loop	RX and TX shorting straps
1	J3 and J4
2	J7 and J8
3	J1 and J2
4	J5 and J6

Connecting expansion modules

If your system includes fiber Trunk Modules, fiber Station Modules, Data Modules or Analog Station Modules, you need to connect the modules to the Expansion Cartridge by means of fiber cables.

Order of connection

In order to keep the default port and telephone numbering:

- Connect Trunk Modules to the Expansion Cartridge beginning at the top and working down.
- Connect Station Modules to the Expansion Cartridge beginning at the bottom and working up.

Analog Station Module

If you are installing the ICS system with an ASM, refer to the diagram below.

Connect jack 1 on the ASM to the first available fibre cable link on the CCU.

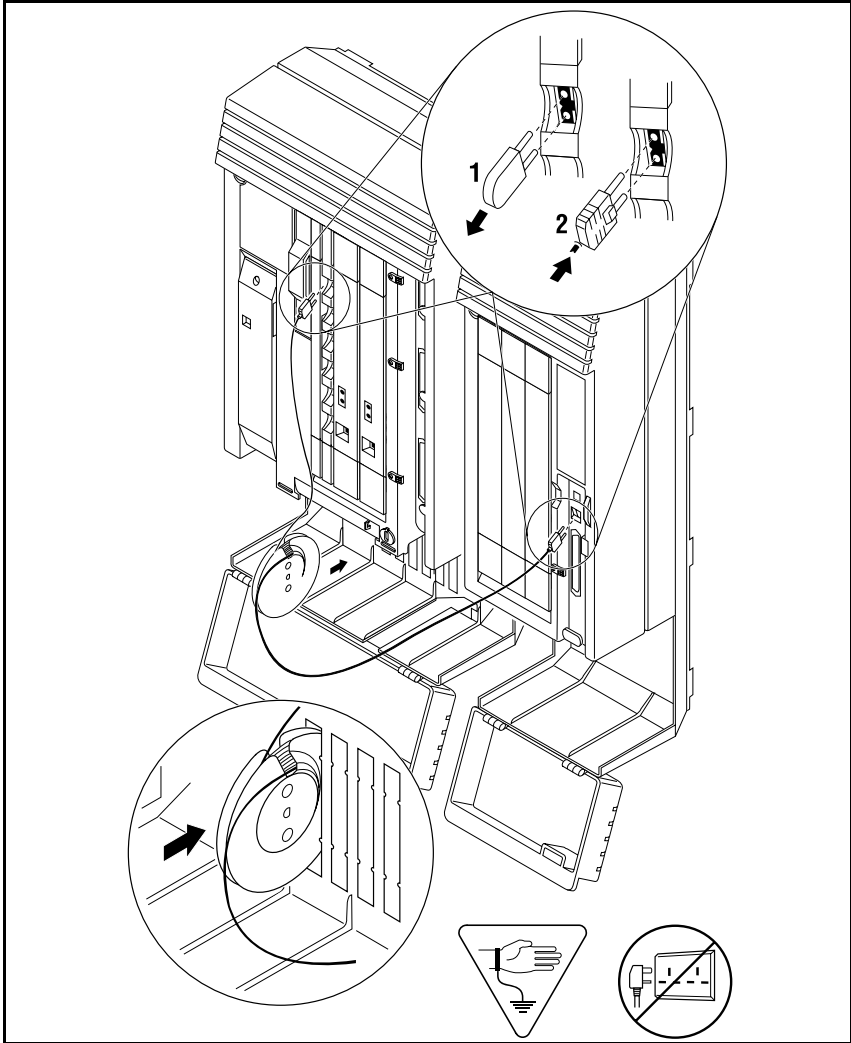
ASM cable connections

The cable trough can accommodate two fibre cable spools. Either slot may be used.

The ASM has three connectors, two fibre cable links and a 25-pair pin connector. Refer to the wiring section for the pinout for the 25-pair pin connector.

Connecting more than one ASM

You can connect additional ASMs.

1. Connect jack 1 on the second ASM to jack 2 on the first ASM.
2. Connect jack 1 on the third ASM to the next available fibre cable link on the on the ICS.
3. The fourth module is connected to the third and so on.
4. Each fibre cable link can support two ASMs.

Connecting multiple modules

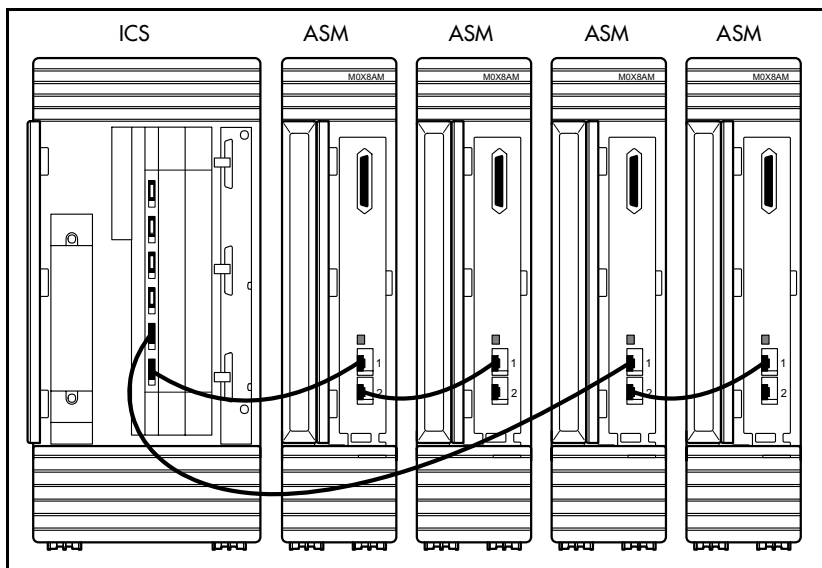

After the modules are mounted and connected, feed the cables through the cable trough.



Tips - On a midi system, ports 3 and 4 can be used for Trunk Modules or Station Modules. In this case, connect Trunk Modules beginning at the top (port 4). Connect Station Modules beginning at the bottom (port 3).

On a maxi system, ports 3 through 8 can be used for Trunk Modules or Station Modules. In this case, Trunk Modules should be connected beginning at the top (port 8) and working down. Station Modules should be connected beginning at the bottom (port 3) and working up.

On a fully expanded 12-port (mega) system, connect Trunk Modules beginning at the top (port 8) and working down. Station Modules would be connected beginning at the bottom (port 3) and working up. Trunk Modules cannot be connected to the Expansion Cartridge in slot 1.

When no more Station Modules can be added to the Expansion Cartridge in slot 2, connect additional Station Modules to the Expansion Cartridge in slot 1, beginning at the bottom (port 9) and working up.

Two-port Expansion Cartridge

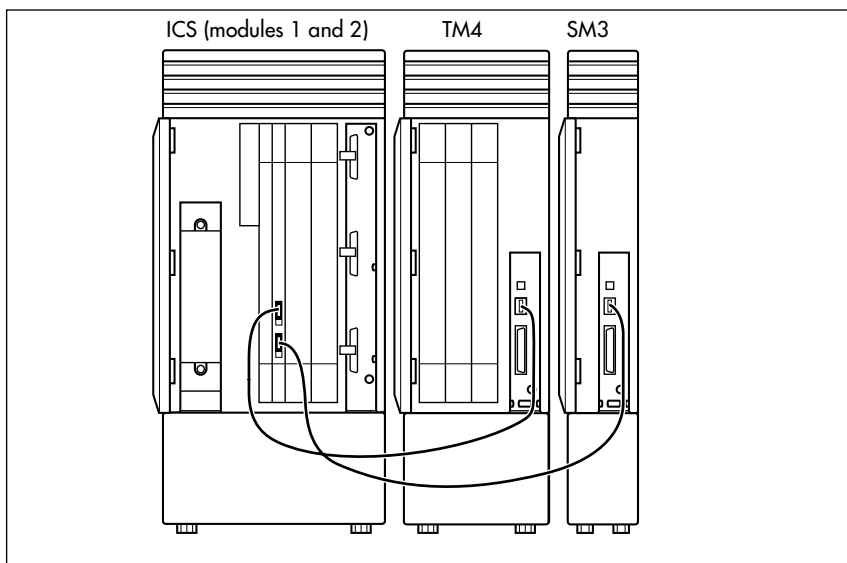

Six-port Expansion Cartridge

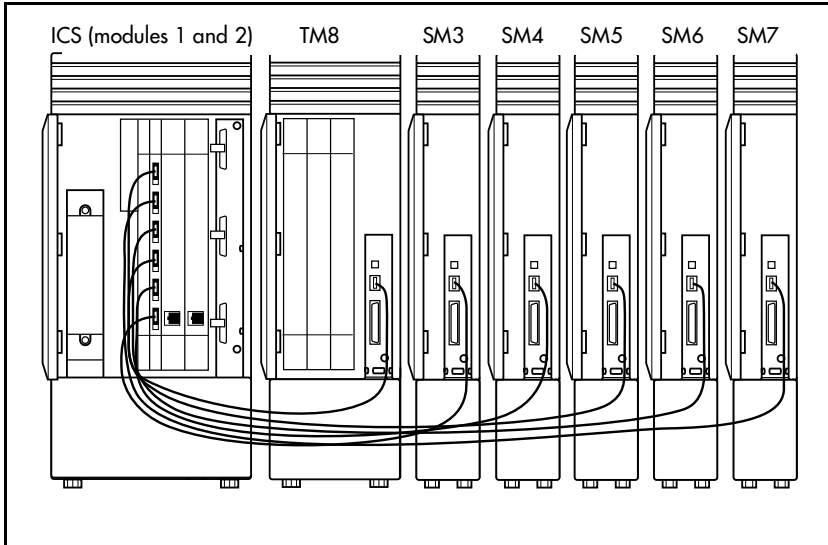

Twelve-port Expansion Cartridge

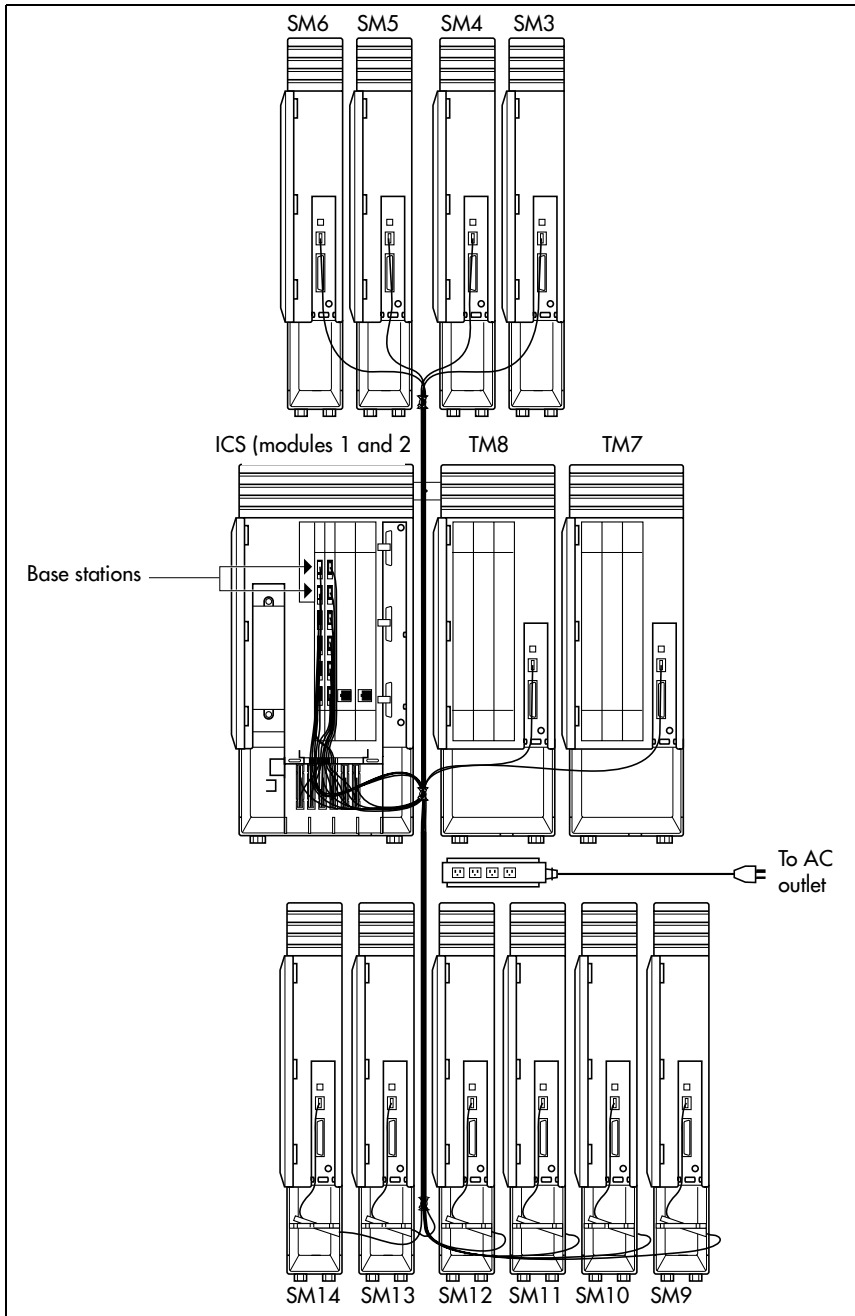

Installing fiber cables



Installing fiber cables.

Fiber cables are durable, but can be damaged. Damaged cables can affect the transmitted signals.

To avoid damaging the cables, observe the following:

- Coil excess fiber cable on the spool provided for the installation.
- Secure the fiber cable spool in the ICS cable trough.
- Ensure that bends in the cable are no tighter than 100 mm. (4 in.) in diameter.
- When using cable ties, bundle fiber cables loosely.
- Avoid excessive pulling, compression or impact.
- Do not grasp the fiber cable, or the clasp where the cable joins the plug, when connecting or disconnecting a fiber cable plug into a port.
- Do not leave fiber cables in an environment with excessively high temperatures (for example, on top of radiators).

Fiber cable management system

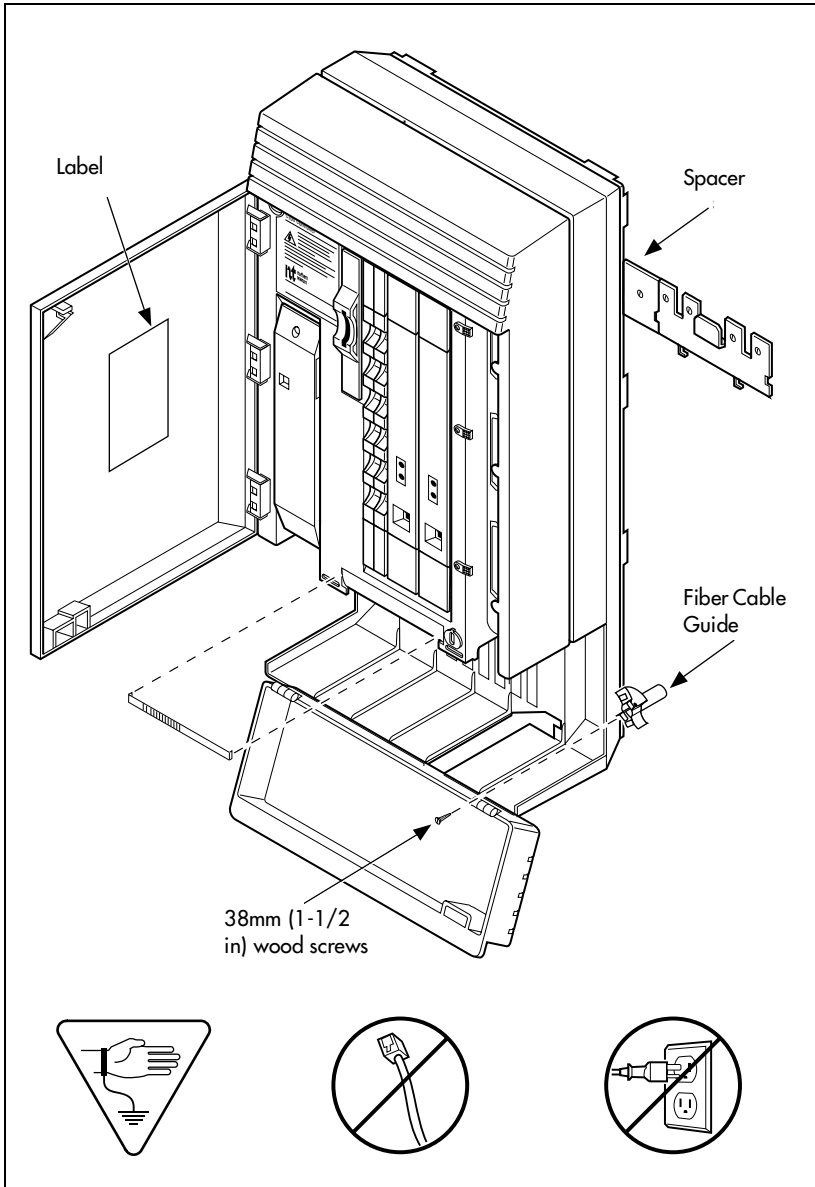

Using the fiber cable management system

To facilitate the installation of an MICS 6.0 or MICS-XC 6.0 configuration, the Fiber Cable Management System ensures that power cords are located outside of the cable tray. It also ensures that a 2.6 cm (1 in.) space exists between the ICS module and other modules.

The following hardware components are used in the Fiber Cable Management System:

- **Fiber Comb (one per system):** The Fiber Comb, is installed, using an adhesive back, on the ICS, below the fiber expansion cartridges. The Fiber Comb keeps the fiber cable in place and prevents the cables from being pinched between doors. Use the comb to keep fiber cables organized as they are routed to each Station Module, as shown in the 12-port example below.

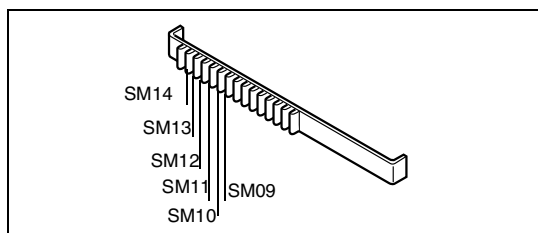

- **Fiber Cable Guide (three per system):** install in the entrance and exit of the cable trough. The Fiber Cable Guide allows fibers to be correctly routed to maintain a minimum bend radius when going through the cable trough.

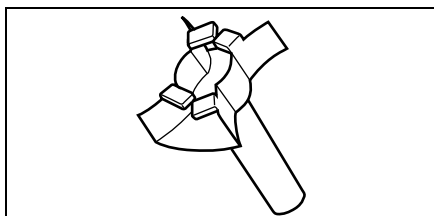

- **Spacer (three per system):** install between the mounting brackets of the ICS and an adjacent module. The Spacer provides a 2.6 cm (1 in.) space between modules and the ICS.

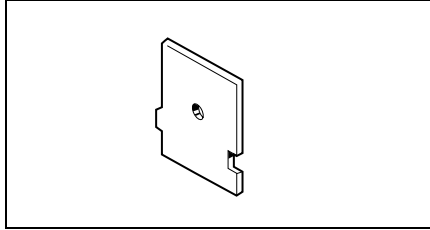

- **Fiber Spool Holder (six per system):** Replaces the trough shelf in modules requiring additional fiber spools. Install the spool holder in the right side of a Trunk Module.

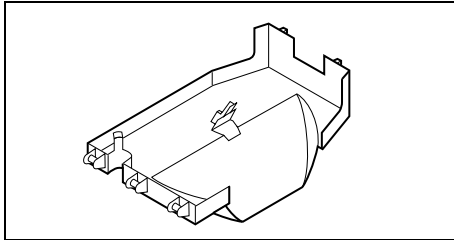

- **ICS Door Label:** Located on the inside of the ICS door, it provides space to identify fiber port allocation on the ICS.

Using the fiber spool

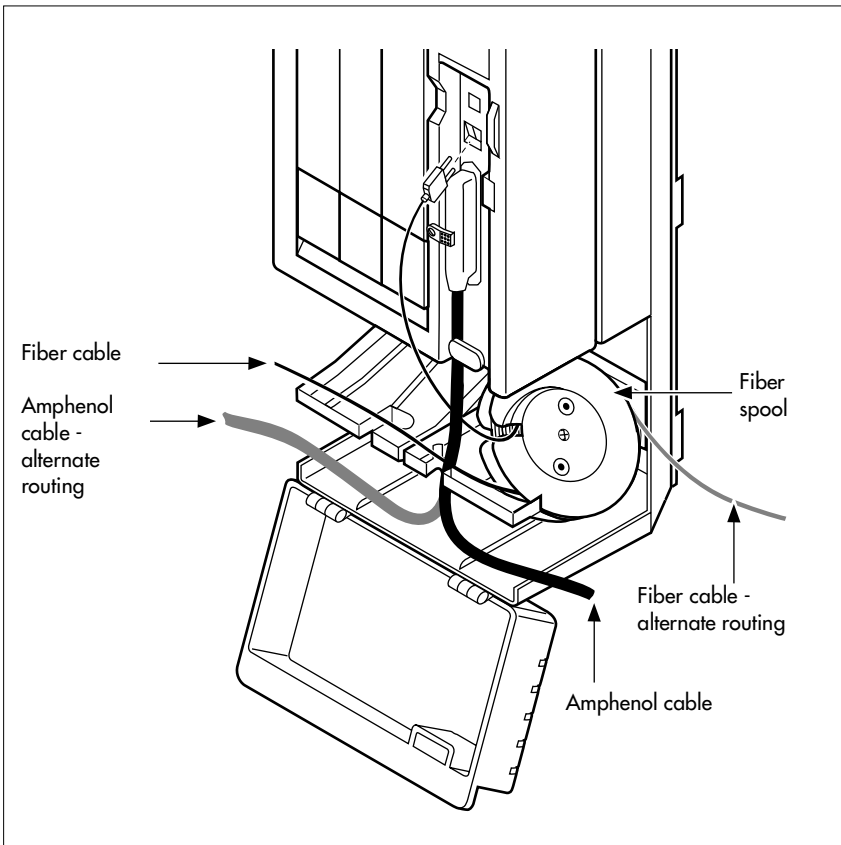

Making fiber connections

MICS-XC 6.0 system

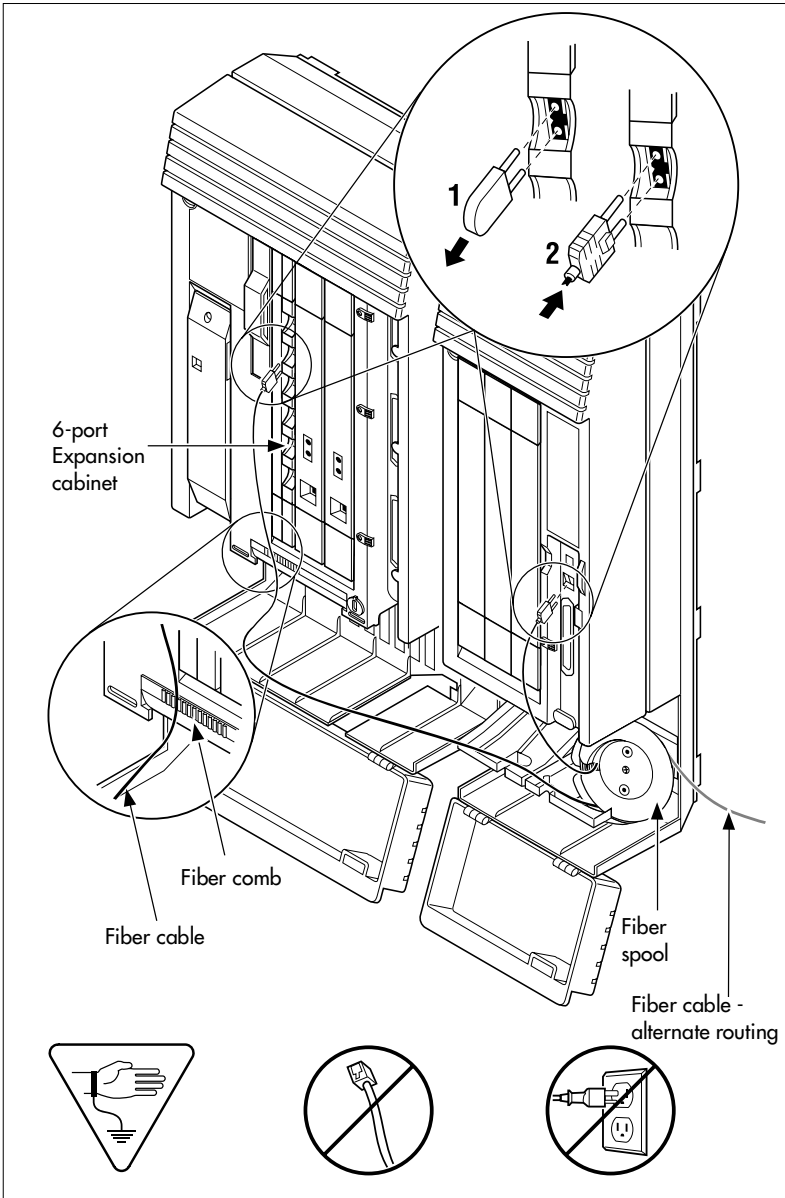

Routing fiber cables

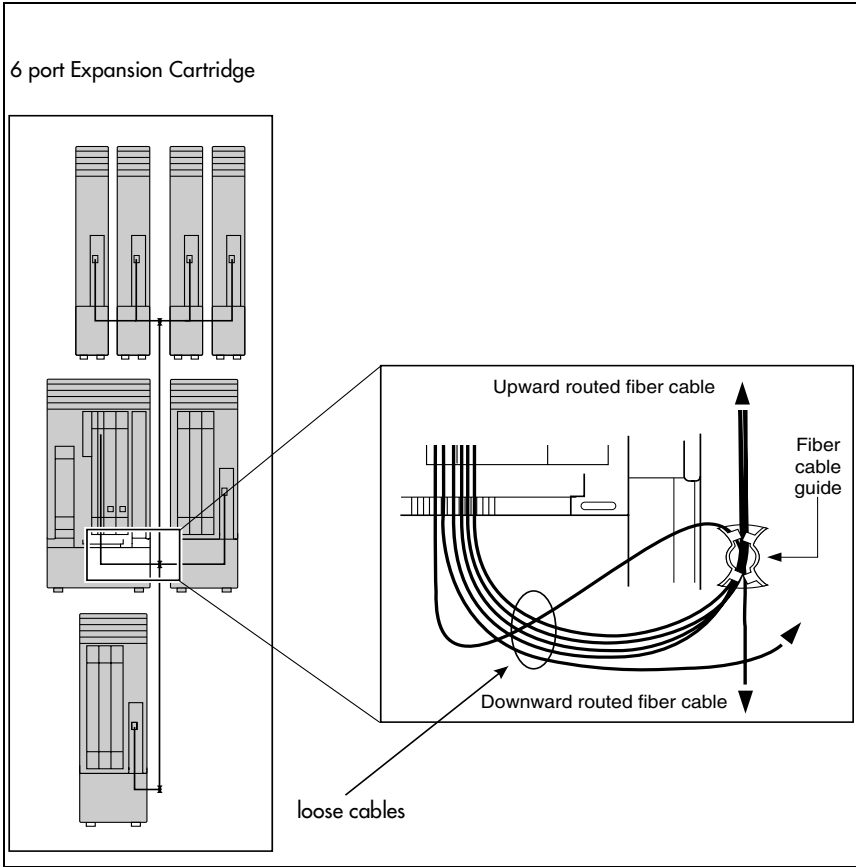

Connecting the wiring

This section describes the wire connections for your MICS system.

Connecting the wiring to the distribution panel

1. Route the cables through the hole in the ICS cable through to the distribution panel.
2. Bundle the cables with cable ties and secure them to the wall to support their weight.
3. Connect the telephone and auxiliary equipment wires to the appropriate pins on the distribution block (refer to the wiring charts).
4. Cross-connect the ICS telephone and auxiliary equipment wiring.
5. Connect the Station Module telephone wiring to the corresponding station pins.
6. Using a single pair of wires for each telephone, connect each of the telephones according to the wiring charts.
7. Cross-connect the external lines to the distribution block — loop start, E&M, DID, BRI. Refer to the wiring charts.
8. The DTI is equipped with an internal channel service unit (CSU). You can connect the DTI directly to the termination point provided by your T1 or PRI service provider. If you disable the internal CSU, you can connect the DTI to an external CSU or multiplexer.

The DTI does not provide the DC connection required for through-fed repeaters. If through-fed repeaters are used on the T1 or PRI span, disable the internal CSU and connect the DTI to an external CSU.

Connecting an ICS with loop start lines

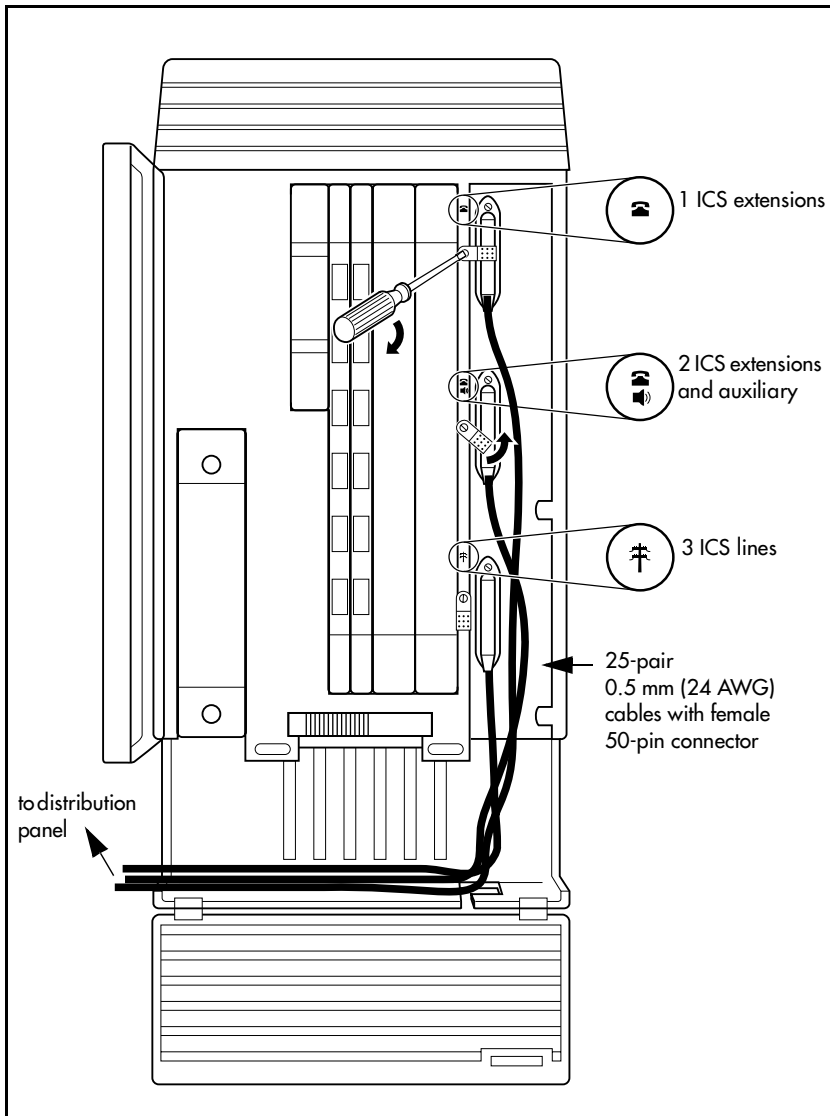

Do not attach central office connections to the ICS or Modules until power is connected to the units.

Connecting the wiring for an ICS with T1 or PRI lines MICS-XC 6.0 system

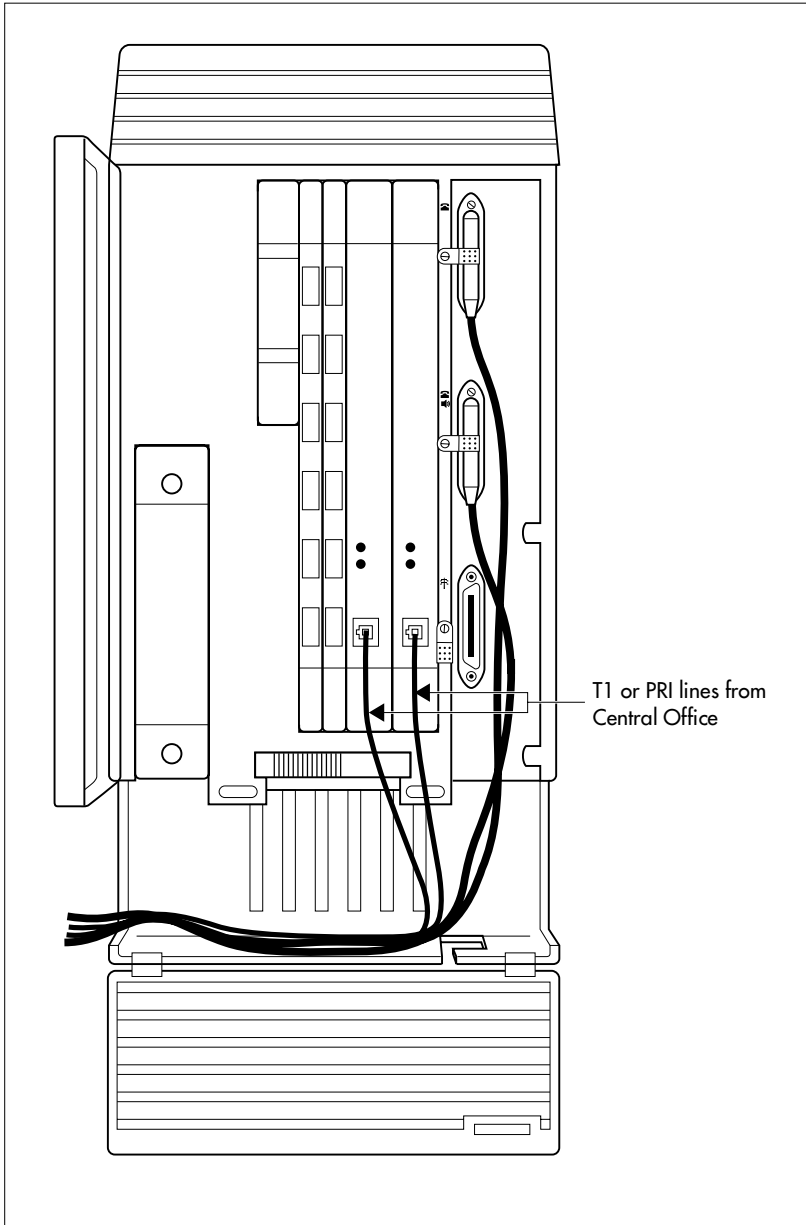

Connecting a module

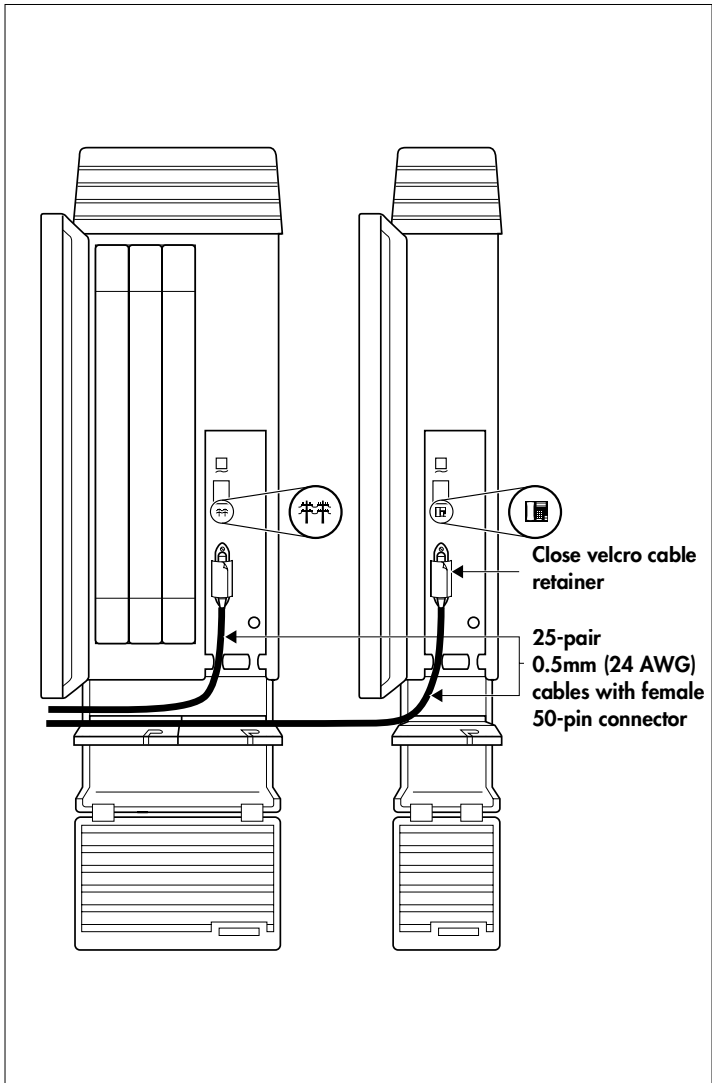

Wiring charts

Port numbering on the wiring charts

The port number listed on the wiring charts is useful in tracking down faults during a maintenance session where error codes appear on the alarm telephone display. Refer to *Alarm codes* on page 506.

The port numbers (for example: XX12) on the Trunk Cartridge and Station Module wiring charts have two components:

- XX corresponds to the number that appears on the face of the Expansion Cartridge port that the Trunk Module or Station Module is connected to.
- digits (for example, 01 or 12) identify an individual port number associated with that module.

For example:

The code 812 appearing as part of an error message for a Trunk Module indicates that the problem is with Expansion Cartridge port #8 and internal port 12. The corresponding Trunk Module pins on the distribution block are pin 47 (violet-orange) and pin 22 (orange-violet).

Integrated Communications System (ICS)

In the charts on the following pages, notice that the ICS has two internal modules, ICS #1 and ICS #2. ICS #1 handles telephones and auxiliary equipment. ICS #2 handles lines.

B1 and B2 directory numbers

The terms B1 and B2 correspond to channels on Norstar for transmitting voice and data. Each DN port number has a B1 DN and a B2 DN. Devices such as the Norstar and Business

Series telephones use only the B1 DN. Other devices may need both B1 and B2 channels, therefore requiring B1 and B2 DNs.

Non-expanded system (ICS alone) numbering

Module	Lines	Line ports	B1 DN	B2 DN	DN ports
ICS (#2)	001-060	201-260	---	---	---
ICS (#1)	---	---	21-52	53-84	101-132

Two-port Expansion Cartridge and ICS numbering

Module	Lines	Line ports	B1 DN	B2 DN	DN ports
Mod 04	133-144	401-412	269-284	333-348	401-416
Mod 03	145-156	301-312	253-268	317-332	301-316
ICS (#2)	001-060	201-260	---	---	---
ICS (#1)	---	---	221-252	285-316	101-132

Six-port Expansion Cartridge and ICS numbering

Module	Lines	Line ports	B1 DN	B2 DN	DN ports
Mod 08	061-084	801-812	333-348	461-476	801-816
Mod 07	085-108	701-712	317-332	445-460	701-716
Mod 06	109-120	601-612	301-316	429-444	601-616
Mod 05	121-132	501-512	285-300	413-428	501-516
Mod 04	133-144	401-412	269-284	397-412	401-416
Mod 03	145-156	301-312	253-268	381-396	301-316
ICS (#2)	001-060	201-260	---	---	---
ICS (#1)	---	---	221-252	349-380	101-132

Twelve-port expanded system and ICS numbering

Module	Lines	Line ports	B1 DN	B2 DN	DN ports
Mod 14	---	---	---	---	---
Mod 13	---	---	---	---	---
Mod 12	---	---	397-412	589-604	1201-1216
Mod 11	---	---	381-396	573-588	1101-1116
Mod 10	---	---	365-380	557-572	1001-1016
Mod 09	---	---	349-364	541-556	901-916
Mod 08	061-084	801-812	333-348	525-540	801-816
Mod 07	085-108	701-712	317-332	509-524	701-716
Mod 06	109-120	601-612	301-316	493-508	601-616
Mod 05	121-132	501-512	285-300	477-492	501-516
Mod 04	133-144	401-412	269-284	461-476	401-416
Mod 03	145-156	301-312	253-268	445-460	301-316
ICS (#2)	001-060	201-260	---	---	---
ICS (#1)	---	---	221-252	413-444	101-132



Tips - A 12-port expanded system is available on a MICS-XC 6.0 system.

Depending on your system configuration, BRI-ST, BRI-U2, and BRI-U4 cards can only reside in certain trunk modules. On a Midi system, the cards must be in trunk modules 03 or 04. On a Maxi or Mega system, the cards must be in trunk modules 07 or 08. The cards can reside in the ICS regardless of system size.

Expansion module #13 and #14 are reserved for Companion Wireless capability. Refer to your Modular ICS Companion Installer Guide for information about using expansion module #13 and #14.

Port 3 is the bottom fiber cable port on both the two-port and the six-port Expansion Cartridge in slot 2. Port 9 is the bottom fiber cable port located on the left most expansion card in slot 1.

B1 and B2 directory numbers reflect the default numbering scheme.

*If you expand your system after initial installation and programming, there may appear to be gaps in your B1 DN numbering. This is because the system has already assigned DN numbers to B2 channels. You can correct these gaps by performing Startup programming and resetting the system memory, or by changing the individual DNs. See **Change DNs** under **System Programming**.*



Startup programming erases the system memory.

ICS telephone wiring chart

Pin	Wire color	Port	Service	Devices (ICS)	Default DN
26	White-Blue	101	T	1	
1	Blue-White	101	R	1	21/221/2221
27	White-Orange	102	T	2	
2	Orange-White	102	R	2	22/222/2222
28	White-Green	103	T	3	
3	Green-White	103	R	3	23/223/2223
29	White-Brown	104	T	4	
4	Brown-White	104	R	4	24/224/2224
30	White-Slate	105	T	5	
5	Slate-White	105	R	5	25/225/2225
31	Red-Blue	106	T	6	
6	Blue-Red	106	R	6	26/226/2226
32	Red-Orange	107	T	7	
7	Orange-Red	107	R	7	27/227/2227
33	Red-Green	108	T	8	
8	Green-Red	108	R	8	28/228/2228
34	Red-Brown	109	T	9	
9	Brown-Red	109	R	9	29/229/2229

Pin	Wire color	Port	Service	Devices (ICS)	Default DN
35	Red-Slate	110	T	10	
10	Slate-Red	110	R	10	30/230/2230
36	Black-Blue	111	T	11	
11	Blue-Black	111	R	11	31/231/2231
37	Black-Orange	112	T	12	
12	Orange-Black	112	R	12	32/232/2232
38	Black-Green	113	T	13	
13	Green-Black	113	R	13	33/233/2233
39	Black-Brown	114	T	14	
14	Brown-Black	114	R	14	34/234/2234
40	Black-Slate	115	T	15	
15	Slate-Black	115	R	15	35/235/2235
41	Yellow-Blue	116	T	16	
16	Blue-Yellow	116	R	16	36/236/2236
42	Yellow-Orange	117	T	17	
17	Orange-Yellow	117	R	17	37/237/2237
43	Yellow-Green	118	T	18	
18	Green-Yellow	118	R	18	38/238/2238
44	Yellow-Brown	119	T	19	
19	Brown-Yellow	119	R	19	39/239/2239
45	Yellow-Slate	120	T	20	
20	Slate-Yellow	120	R	20	40/240/2240
46	Violet-Blue	121	T	21	
21	Blue-Violet	121	R	21	41/241/2241
47	Violet-Orange	122	T	22	
22	Orange-Violet	122	R	22	42/242/2242
48	Violet-Green	123	T	23	
23	Green-Violet	123	R	23	43/243/2243
49	Violet-Brown	124	T	24	
24	Brown-Violet	124	R	24	44/244/2244
50	Violet-Slate	----	----	no connection	----
25	Slate-Violet	----	----	no connection	----

T and R represent station connections and should not be confused with Tip and Ring on external lines. Station connections are non-polarized.

ICS telephone and auxiliary equipment wiring chart

Pin	Wire color	Port	Service	Telephones (ICS)	Default DN
26	White-Blue	125	T	25	
1	Blue-White	125	R	25	45/245/2245
27	White-Orange	126	T	26	
2	Orange-White	126	R	26	46/246/2246
28	White-Green	127	T	27	

Pin	Wire color	Port	Service	Telephones (ICS)	Default DN
3	Green-White	127	R	27	47/247/2247
29	White-Brown	128	T	28	
4	Brown-White	128	R	28	48/248/2248
30	White-Slate	129	T	29	
5	Slate-White	129	R	29	49/249/2249
31	Red-Blue	130	T	30	
6	Blue-Red	130	R	30	50/250/2250
32	Red-Orange	131	T	31	
7	Orange-Red	131	R	31	51/251/2251
33	Red-Green	132	T	32	
8	Green-Red	132	R	32	52/252/2252
34	Red-Brown	----	----	no connection	
9	Brown-Red	----	----	no connection	
35	Red-Slate	----	----	no connection	
10	Slate-Red	----	----	no connection	
36	Black-Blue	----	----	no connection	
11	Blue-Black	----	----	no connection	
37	Black-Orange	----	----	no connection	
12	Orange-Black	----	----	no connection	
38	Black-Green	----	----	no connection	
13	Green-Black	----	----	no connection	
39	Black-Brown	----	----	no connection	
14	Brown-Black	----	----	no connection	
40	Black-Slate	----	T	Page	
15	Slate-Black	----	R	Page	
41	Yellow-Blue	----	Make	External page	
16	Blue-Yellow	----	Common	External page	
42	Yellow-Orange	----	T	Music	
17	Orange-Yellow	----	R	Music	
43	Yellow-Green	----	----	reserved	
18	Green-Yellow	----	----	reserved	
44	Yellow-Brown	----	Make	Auxiliary ringer - 1	
19	Brown-Yellow	----	Common	Auxiliary ringer - 1	
45	Yellow-Slate	----	----	reserved	
20	Slate-Yellow	----	----	reserved	
46	Violet-Blue	----	----	no connection	
21	Blue-Violet	----	----	no connection	
47	Violet-Orange	----	----	reserved	
22	Orange-Violet	----	----	reserved	
48	Violet-Green	----	----	reserved	
23	Green-Violet	----	----	reserved	
49	Violet-Brown	----	----	reserved	

Pin	Wire color	Port	Service	Telephones (ICS)	Default DN
24	Brown-Violet	----	----	reserved	
50	Violet-Slate	----	----	reserved	
25	Slate-Violet	----	----	reserved	

T and R represent station connections and should not be confused with Tip and Ring on external lines. Station connections are non-polarized.

ICS external loop start lines wiring

Pin	Wire color	Port	Service	Line
26	White-Blue	201	T	1
1	Blue-White	201	R	1
27	White-Orange	202	T	2
2	Orange-White	202	R	2
28	White-Green	----	----	----
3	Green-White	----	----	----
29	White-Brown	----	----	----
4	Brown-White	----	----	----
30	White-Slate	203	T	3
5	Slate-White	203	R	3
31	Red-Blue	204	T	4
6	Blue-Red	204	R	4
32	Red-Orange	----	----	----
7	Orange-Red	----	----	----
33	Red-Green	----	----	----
8	Green-Red	----	----	----
34	Red-Brown	225	T	25
9	Brown-Red	225	R	25
35	Red-Slate	226	T	26
10	Slate-Red	226	R	26
36	Black-Blue	----	----	----
11	Blue-Black	----	----	----
37	Black-Orange	----	----	----
12	Orange-Black	----	----	----
38	Black-Green	227	T	27
13	Green-Black	227	R	27
39	Black-Brown	228	T	28
14	Brown-Black	228	R	28
40	Black-Slate	----	----	----
15	Slate-Black	----	----	----
41	Yellow-Blue	----	----	----
16	Blue-Yellow	----	----	----
42	Yellow-Orange	----	----	----
17	Orange-Yellow	----	----	----

Pin	Wire color	Port	Service	Line
43	Yellow-Green	----	T	ET1
18	Green-Yellow	----	R	ET1
44	Yellow-Brown	----	T	ET2
19	Brown-Yellow	----	R	ET2
45	Yellow-Slate	----	----	----
20	Slate-Yellow	----	----	----
46	Violet-Blue	----	----	----
21	Blue-Violet	----	----	----
47	Violet-Orange	----	----	----
22	Orange-Violet	----	----	----
48	Violet-Green	----	----	----
23	Green-Violet	----	----	----
49	Violet-Brown	----	----	----
24	Brown-Violet	----	----	----
50	Violet-Slate	----	----	----
25	Slate-Violet	----	----	----

For an explanation of port numbering, see *Port numbering on the wiring charts* on page 241.

BRI Wiring charts

A BRI Card in Slot 4 uses loops 201 through 204. A BRI card in Slot 3 uses loops 225 through 228. Because a BRI-U2 Card has only two loops, it only uses the first two loop numbers (201-202 and 225-226) when it occupies an ICS slot.

The loops appearing on a BRI card may be automatically assigned lines, or assigned one or more ISDN DNs in **Hardware**. If the loop is configured as T or NT, lines are automatically assigned. If the loop is configured as S or LT, you can assign one or more ISDN DNs to the loop.

The emergency telephone connections (ET2 and ET1) cannot be used if a BRI card is installed in Slot 3 or Slot 4, respectively.

For more information about configuring BRI cards refer to *BRI Card* on page 48 in *Welcome to ISDN* and *BRI card* on page 471 in *Hardware*.

ICS ST Interface Cards wiring

Pin	Wire color	Port (loop)	Service	Lines (T-loop)	Terminal equipment (S loop)
26	White-Blue	201	+Tx	001-002	Assigned DN
1	Blue-White	201	-Tx	001-002	Assigned DN
27	White-Orange	201	+Rx	001-002	Assigned DN
2	Orange-White	201	-Rx	001-002	Assigned DN
28	White-Green	202	+Tx	003-004	Assigned DN
3	Green-White	202	-Tx	003-004	Assigned DN
29	White-Brown	202	+Rx	003-004	Assigned DN
4	Brown-White	202	-Rx	003-004	Assigned DN
30	White-Slate	203	+Tx	005-006	Assigned DN
5	Slate-White	203	-Tx	005-006	Assigned DN
31	Red-Blue	203	+Rx	005-006	Assigned DN
6	Blue-Red	203	-Rx	005-006	Assigned DN
32	Red-Orange	204	+Tx	007-008	Assigned DN
7	Orange-Red	204	-Tx	007-008	Assigned DN
33	Red-Green	204	+Rx	007-008	Assigned DN
8	Green-Red	204	-Rx	007-008	Assigned DN
34	Red-Brown	225	+Tx	025-026	Assigned DN
9	Brown-Red	225	-Tx	025-026	Assigned DN
35	Red-Slate	225	+Rx	025-026	Assigned DN
10	Slate-Red	225	-Rx	025-026	Assigned DN
36	Black-Blue	226	+Tx	027-028	Assigned DN
11	Blue-Black	226	-Tx	027-028	Assigned DN
37	Black-Orange	226	+Rx	027-028	Assigned DN
12	Orange-Black	226	-Rx	027-028	Assigned DN
38	Black-Green	227	+Tx	029-030	Assigned DN
13	Green-Black	227	-Tx	029-030	Assigned DN
39	Black-Brown	227	+Rx	029-030	Assigned DN
14	Brown-Black	227	-Rx	029-030	Assigned DN
40	Black-Slate	228	+Tx	031-032	Assigned DN
15	Slate-Black	228	-Tx	031-032	Assigned DN
41	Yellow-Blue	228	+Rx	031-032	Assigned DN
16	Blue-Yellow	228	-Rx	031-032	Assigned DN
42	Yellow-Orange	----	----	----	---

ICS ST Interface Cards wiring (Continued)

Pin	Wire color	Port (loop)	Service	Lines (T-loop)	Terminal equipment (S loop)
17	Orange-Yellow	----	----	----	---
43	Yellow-Green	----	T	ET1	---
18	Green-Yellow	----	R	ET1	---
44	Yellow-Brown	----	T	ET2	---
19	Brown-Yellow	----	R	ET2	---
45	Yellow-Slate	----	----	----	---
20	Slate-Yellow	----	----	----	---
46	Violet-Blue	----	----	----	---
21	Blue-Violet	----	----	----	---
47	Violet-Orange	----	----	----	---
22	Orange-Violet	----	----	----	---
48	Violet-Green	----	----	----	---
23	Green-Violet	----	----	----	---
49	Violet-Brown	----	----	----	---
24	Brown-Violet	----	----	----	---
50	Violet-Slate	----	----	----	---
25	Slate-Violet	----	----	----	---

BRI S or T wiring is polarity sensitive.
Tx and Rx are Transmit and Receive for Norstar.

ICS U Interface Cards wiring

Pin	Wire color	Port (loop)	Service	Lines (U-NT)	Terminal equipment (U-LT)
26	White-Blue	201	T	001-002	Assigned DN
1	Blue-White	201	R	001-002	Assigned DN
27	White-Orange	202	T	003-004	Assigned DN
2	Orange-White	202	R	003-004	Assigned DN
28	White-Green	----	----	----	----
3	Green-White	----	----	----	----
29	White-Brown	----	----	----	----
4	Brown-White	----	----	----	----
30	White-Slate	203	T	005-006	Assigned DN
5	Slate-White	203	R	005-006	Assigned DN
31	Red-Blue	204	T	007-008	Assigned DN
6	Blue-Red	204	R	007-008	Assigned DN
32	Red-Orange	----	----	----	----
7	Orange-Red	----	----	----	----

ICS U Interface Cards wiring (Continued)

Pin	Wire color	Port (loop)	Service	Lines (U-NT)	Terminal equipment (U-LT)
33	Red-Green	----	----	----	----
8	Green-Red	----	----	----	----
34	Red-Brown	225	T	025-026	Assigned DN
9	Brown-Red	225	R	025-026	Assigned DN
35	Red-Slate	226	T	027-028	Assigned DN
10	Slate-Red	226	R	027-028	Assigned DN
36	Black-Blue	----	----	----	----
11	Blue-Black	----	----	----	----
37	Black-Orange	----	----	----	----
12	Orange-Black	----	----	----	----
38	Black-Green	227	T	029-030	Assigned DN
13	Green-Black	227	R	029-030	Assigned DN
39	Black-Brown	228	T	031-032	Assigned DN
14	Brown-Black	228	R	031-032	Assigned DN
40	Black-Slate	----	----	----	----
15	Slate-Black	----	----	----	----
41	Yellow-Blue	----	----	----	----
16	Blue-Yellow	----	----	----	----
42	Yellow-Orange	----	----	----	----
17	Orange-Yellow	----	----	----	----
43	Yellow-Green	----	----	----	----
18	Green-Yellow	----	----	----	----
44	Yellow-Brown	----	----	----	----
19	Brown-Yellow	----	----	----	----
45	Yellow-Slate	----	----	----	----
20	Slate-Yellow	----	----	----	----
46	Violet-Blue	----	----	----	----
21	Blue-Violet	----	----	----	----
47	Violet-Orange	----	----	----	----
22	Orange-Violet	----	----	----	----
48	Violet-Green	----	----	----	----
23	Green-Violet	----	----	----	----
49	Violet-Brown	----	----	----	----
24	Brown-Violet	----	----	----	----
50	Violet-Slate	----	----	----	----
25	Slate-Violet	----	----	----	----

BRI U wiring is not polarity sensitive.

Wiring the BRI network interface

A network interface provides the connection between the ISDN network and the Modular ICS.

If the card in the ICS is configured as a T-loop, the ICS is wired to the network connection using an NT1.

See *T reference points* on page 51 for more information about the NT1.

Wiring for T network connection

Pin (jack or plug)	NT1 connection (for jack)	ICS and optional TE connection (plug)
1	not used	optional power source 3 (+)
2	not used	optional power source 3 (-)
3	+Rx	+Tx
4	+Tx	+Rx
5	-Tx	-Rx
6	-Rx	-Tx
7	not used	optional power sink 2 (-)
8	not used	optional power sink 2 (+)

The Modular ICS supplies the NT1 functionality to a U-NT loop, allowing a direct connection to the network. The connection may use a plug and jack, or may be directly wired.

Wiring for U-NT network interface

Pin (jack or plug)	Norstar connection (for plug to network interface jack)	Network interface connection (jack)
1	not used	optional battery status indicator (+)
2	not used	optional battery status indicator (-)
3	not used	no connection
4	R	R
5	T	T

6	not used	no connection
7	not used	optional power supply (-)
8	not used	optional power supply (+)

The BRI-U Card does not use or provide optional power.

Some installations may not use a plug and jack for connections between the ICS (NT) and the network.

The following illustration shows the pin arrangement for a Bellcore standard ISDN plug and jack. Other pin arrangements are possible.

Jack and plug pin numbering

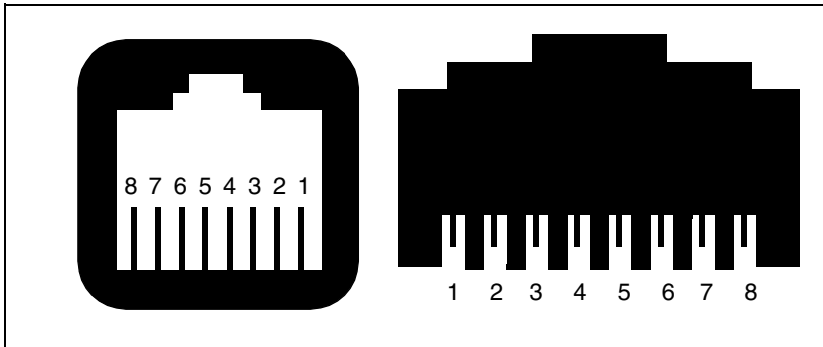

DTI wiring

Connecting the DTI to the T1 or PRI service provider

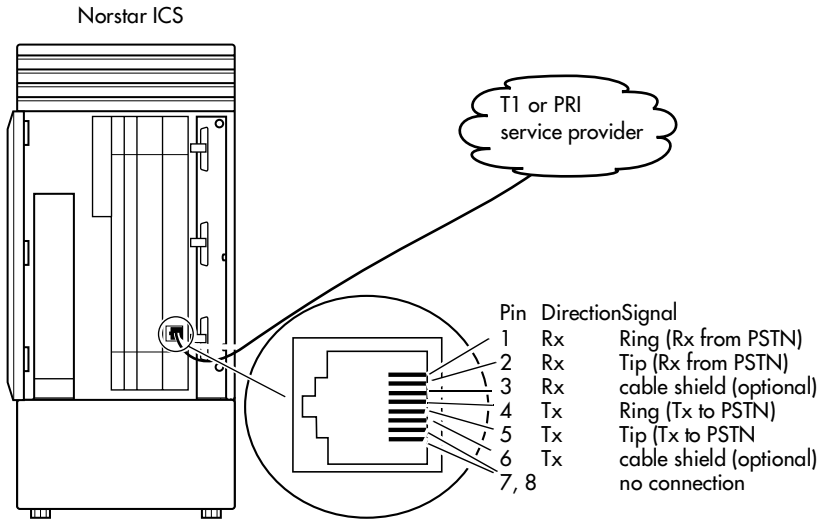

Connecting the DTI to an external CSU

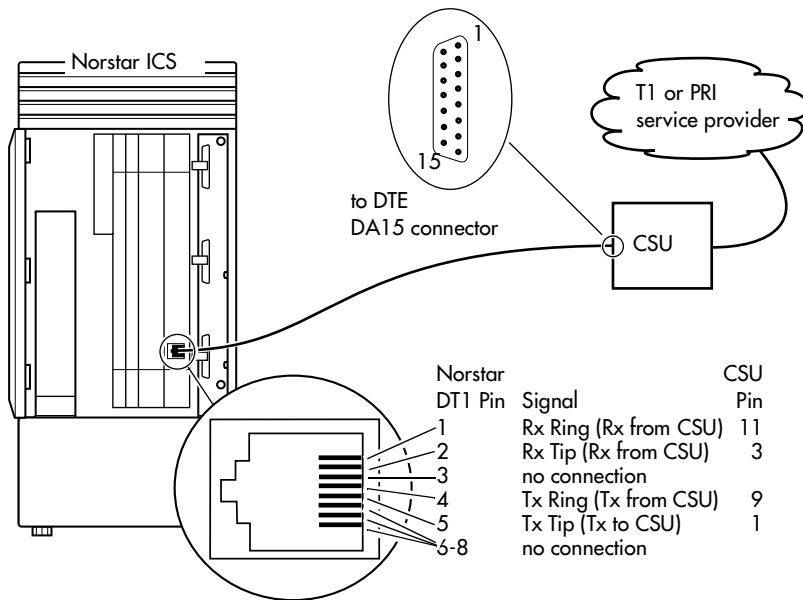

Station Module wiring chart

Pin	Wire color	Port	Service	Telephones SM
26	White-Blue	X01	T	1
1	Blue-White	X01	R	1
27	White-Orange	X02	T	2
2	Orange-White	X02	R	2
28	White-Green	X03	T	3
3	Green-White	X03	R	3
29	White-Brown	X04	T	4
4	Brown-White	X04	R	4
30	White-Slate	X05	T	5
5	Slate-White	X05	R	5
31	Red-Blue	X06	T	6
6	Blue-Red	X06	R	6
32	Red-Orange	X07	T	7
7	Orange-Red	X07	R	7
33	Red-Green	X08	T	8
8	Green-Red	X08	R	8
34	Red-Brown	X09	T	9
9	Brown-Red	X09	R	9
35	Red-Slate	X10	T	10
10	Slate-Red	X10	R	10
36	Black-Blue	X11	T	11
11	Blue-Black	X11	R	11
37	Black-Orange	X12	T	12
12	Orange-Black	X12	R	12
38	Black-Green	X13	T	13
13	Green-Black	X13	R	13
39	Black-Brown	X14	T	14
14	Brown-Black	X14	R	14
40	Black-Slate	X15	T	15
15	Slate-Black	X15	R	15
41	Yellow-Blue	X16	T	16
16	Blue-Yellow	X16	R	16
42	Yellow-Orange	----	----	no connection
17	Orange-Yellow	----	----	no connection
43	Yellow-Green	----	----	no connection
18	Green-Yellow	----	----	no connection
44	Yellow-Brown	----	----	no connection
19	Brown-Yellow	----	----	no connection
45	Yellow-Slate	----	----	no connection
20	Slate-Yellow	----	----	no connection
46	Violet-Blue	----	----	no connection

Station Module wiring chart (Continued)

Pin	Wire color	Port	Service	Telephones SM
21	Blue-Violet	----	----	no connection
47	Violet-Orange	----	----	no connection
22	Orange-Violet	----	----	no connection
48	Violet-Green	----	----	no connection
23	Green-Violet	----	----	no connection
49	Violet-Brown	----	----	no connection
24	Brown-Violet	----	----	no connection
50	Violet-Slate	----	----	no connection
25	Slate-Violet	----	----	no connection

T and R represent station connections and should not be confused with Tip and Ring on external lines. Station connections are non-polarized.

For an explanation of port numbering, see *Port numbering on the wiring charts* on page 241.

Loop Start or CI Trunk Cartridge wiring chart

TC Slot	Pin	Wire color	Port	Service	Line
Slot 1	26	White-Blue	X01	T	1
	1	Blue-White	X01	R	1
	27	White-Orange	X02	T	2
	2	Orange-White	X02	R	2
	28	White-Green	----	No connection	----
	3	Green-White	----	No connection	----
	29	White-Brown	----	No connection	----
	4	Brown-White	----	No connection	----
	30	White-Slate	X03	T	3
	5	Slate-White	X03	R	3
	31	Red-Blue	X04	T	4
	6	Blue-Red	X04	R	4
	32	Red-Orange	----	No connection	----
7	Orange-Red	----	No connection	----	
33	Red-Green	----	No connection	----	
8	Green-Red	----	No connection	----	
Slot 2	34	Red-Brown	X05	T	5
	9	Brown-Red	X05	R	5
	35	Red-Slate	X06	T	6
	10	Slate-Red	X06	R	6
	36	Black-Blue	----	No connection	----
	11	Blue-Black	----	No connection	----
	37	Black-Orange	----	No connection	----
	12	Orange-Black	----	No connection	----
	38	Black-Green	X07	T	7
	13	Green-Black	X07	R	7

Loop Start or CI Trunk Cartridge wiring chart (Continued)

TC Slot	Pin	Wire color	Port	Service	Line
	39	Black-Brown	X08	T	8
	14	Brown-Black	X08	R	8
	40	Black-Slate	----	No connection	----
	15	Slate-Black	----	No connection	----
	41	Yellow-Blue	----	No connection	----
Slot 3	42	Yellow-Orange	X09	T	9
	17	Orange-Yellow	X09	R	9
	43	Yellow-Green	X10	T	10
	18	Green-Yellow	X10	R	10
	44	Yellow-Brown	----	No connection	----
	19	Brown-Yellow	----	No connection	----
	45	Yellow-Slate	----	No connection	----
	20	Slate-Yellow	----	No connection	----
	46	Violet-Blue	X11	T	11
	21	Blue-Violet	X11	R	11
	47	Violet-Orange	X12	T	12
	22	Orange-Violet	X12	R	12
	48	Violet-Green	----	No connection	----
	23	Green-Violet	----	No connection	----
	49	Violet-Brown	----	No connection	----
24	Brown-Violet	----	No connection	----	
	50	Violet-Slate	----	ET	----
	25	Slate-Violet	----	ET	----

For an explanation of port numbering, see *Port numbering on the wiring charts* on page 241.

E&M/DISA Trunk Cartridge wiring chart

Use the table, *Trunk Module with E&M/DISA Trunk Cartridges*, on page 258 when a Trunk Module has only E&M/DISA Trunk Cartridges.

If the Norstar system is being connected to another Norstar system or private branch exchange by connecting two RJ2HX/CA2HA distribution blocks together, use the following table to determine the required cross-connections.

Back-to-back cross-connections

1st distribution block	T	R	T1	R1	E	SG	M	SB
Next distribution block	T1	R1	T	R	SB	M	SG	E



Tips - *When installing a mixture of E&M/DISA, DID, BRI, or Loop Start Trunk Cartridges, it is important to cross-connect the wiring for each type of TC to a separate distribution block.*

To verify the operation of the Norstar E&M cards and the target lines, wire the two E&M lines on the Norstar E&M back to back.

The cross-connections to each distribution block must always begin at pins 26 and 1. To retain emergency telephone function, install a Loop Start Trunk Cartridge in the left-most slot (slot 1) of the TM.

Trunk Module with E&M/DISA Trunk Cartridges

TC Slot	Pin	Wire color	Port	Service	Line
Slot 1	26	White-Blue	X01	T	1
	1	Blue-White	X01	R	1
	27	White-Orange	X01	T1	1
	2	Orange-White	X01	R1	1
	28	White-Green	X01	E	1
	3	Green-White	X01	SG	1
	29	White-Brown	X01	M	1
	4	Brown-White	X01	SB	1
	30	White-Slate	X02	T	2
	5	Slate-White	X02	R	2
	31	Red-Blue	X02	T1	2
	6	Blue-Red	X02	R1	2
	32	Red-Orange	X02	E	2
	7	Orange-Red	X02	SG	2
	33	Red-Green	X02	M	2
	8	Green-Red	X02	SB	2
Slot 2	34	Red-Brown	X05	T	5
	9	Brown-Red	X05	R	5
	35	Red-Slate	X05	T1	5
	10	Slate-Red	X05	R1	5
	36	Black-Blue	X05	E	5
	11	Blue-Black	X05	SG	5
	37	Black-Orange	X05	M	5
	12	Orange-Black	X05	SB	5
	38	Black-Green	X06	T	6

Trunk Module with E&M/DISA Trunk Cartridges (Continued)

TC Slot	Pin	Wire color	Port	Service	Line
	13	Green-Black	X06	R	6
	39	Black-Brown	X06	T1	6
	14	Brown-Black	X06	R1	6
	40	Black-Slate	X06	E	6
	15	Slate-Black	X06	SG	6
	41	Yellow-Blue	X06	M	6
	16	Blue-Yellow	X06	SB	6
Slot 3	42	Yellow-Orange	X09	T	9
	17	Orange-Yellow	X09	R	9
	43	Yellow-Green	X09	T1	9
	18	Green-Yellow	X09	R1	9
	44	Yellow-Brown	X09	E	9
	19	Brown-Yellow	X09	SG	9
	45	Yellow-Slate	X09	M	9
	20	Slate-Yellow	X09	SB	9
	46	Violet-Blue	X10	T	10
	21	Blue-Violet	X10	R	10
	47	Violet-Orange	X10	T1	10
	22	Orange-Violet	X10	R1	10
	48	Violet-Green	X10	E	10
	23	Green-Violet	X10	SG	10
	49	Violet-Brown	X10	M	10
	24	Brown-Violet	X10	SB	10
	50	Violet-Slate	----	reserved	----
	25	Slate-Violet	----	reserved	----

For an explanation of port numbering, see *Port numbering on the wiring charts* on page 241.

Trunk Module with DID Trunk Cartridges

TC Slot	Pin	Wire color	Port	Service	Line
Slot 1	26	White-Blue	X01	T	1
	1	Blue-White	X01	R	1
	27	White-Orange	X02	T	2
	2	Orange-White	X02	R	2
	28	White-Green	----	No connection	----
	3	Green-White	----	No connection	----
	29	White-Brown	----	CCI NC1	----
	4	Brown-White	----	CCI Com1	----
	30	White-Slate	X03	T	3
	5	Slate-White	X03	R	3
	31	Red-Blue	X04	T	4

Trunk Module with DID Trunk Cartridges (Continued)

TC Slot	Pin	Wire color	Port	Service	Line
	6	Blue-Red	X04	R	4
	32	Red-Orange	----	No connection	----
	7	Orange-Red	----	No connection	----
	33	Red-Green	----	No connection	----
	8	Green-Red	----	No connection	----
Slot 2	34	Red-Brown	X05	T	5
	9	Brown-Red	X05	R	5
	35	Red-Slate	X06	T	6
	10	Slate-Red	X06	R	6
	36	Black-Blue	----	No connection	----
	11	Blue-Black	----	No connection	----
	37	Black-Orange	----	CCI NC1	----
	12	Orange-Black	----	CCI Com1	----
	38	Black-Green	X07	T	7
	13	Green-Black	X07	R	7
	39	Black-Brown	X08	T	8
	14	Brown-Black	X08	R	8
	40	Black-Slate	----	No connection	----
	15	Slate-Black	----	No connection	----
	41	Yellow-Blue	----	No connection	----
	16	Blue-Yellow	----	No connection	----
Slot 3	42	Yellow-Orange	X09	T	9
	17	Orange-Yellow	X09	R	9
	43	Yellow-Green	X10	T	10
	18	Green-Yellow	X10	R	10
	44	Yellow-Brown	----	No connection	----
	19	Brown-Yellow	----	No connection	----
	45	Yellow-Slate	----	CCI NC1	----
	20	Slate-Yellow	----	CCI Com1	----
	46	Violet-Blue	X11	T	11
	21	Blue-Violet	X11	R	11
	47	Violet-Orange	X12	T	12
	22	Orange-Violet	X12	R	12
	48	Violet-Green	----	No connection	----
	23	Green-Violet	----	No connection	----
	49	Violet-Brown	----	No connection	----
	24	Brown-Violet	----	No connection	----
	50	Violet-Slate	----	ET	----
	25	Slate-Violet	----	ET	----

For an explanation of port numbering, see *Port numbering on the wiring charts* on page 241.

For CCI connections in Service column: NC1 stands for the normally closed relay and Com1 the common relay.

CCI signaling is not supported by all carriers. For carriers or installations that do not use CCI signaling, the CCI and ET connections should be treated as "no connection". CCI wiring is a non-standard wiring arrangement which has been submitted to the DOC.

DID supervisory signaling

This equipment returns supervisory signals to the public switched telephone network (PSTN) when the DID calls are:

- answered by the called telephone
- answered by the attendant
- routed to a customer controlled recorded announcement
- routed to a dial prompt

This equipment is designed to return supervisory signals on all DID calls forwarded through the system back to the PSTN within 20 seconds of call forwarding being initiated.

Emergency transfer conditions

Every DID Trunk Cartridge has a Control Circuit Interface (CCI) which should be connected directly to the central office for monitoring purposes.

If the Norstar system loses power or the microcontroller on the DID Trunk Cartridge malfunctions, the CCI signals the central office that it can no longer handle DID calls. The central office, by prearrangement, then forwards the DID lines to other numbers.

Connect the CCI com1 connection to a ground connection. Connect the CCI NC1 connection to the central office demarcation.



Tips - *CCI signaling to report power loss or malfunction of the DID Trunk Cartridge is not supported by all carriers. For carriers or installations which do not use CCI signaling, the CCI and ET connections are treated as not connected.*

Wire each CCI independently to the central office. If the connections are wired in parallel, any CCI trouble disables all DID Trunk Cartridges. If the connections are wired in series, all DID Trunk Cartridges must fail before the central office recognizes the trouble condition.

Trunk Module with BRI-ST cartridge

TC slot	Pin	Wire color	Port (loop)	Service	Lines (T or S loop)	Terminal equipment S loop)
Slot 1	26	White-Blue	X01	+Tx	001-002	Assigned DN
	1	Blue-White	X01	-Tx	001-002	Assigned DN
	27	White-Orange	X01	+Rx	001-002	Assigned DN
	2	Orange-White	X01	-Rx	001-002	Assigned DN
	28	White-Green	X02	+Tx	003-004	Assigned DN
	3	Green-White	X02	-Tx	003-004	Assigned DN
	29	White-Brown	X02	+Rx	003-004	Assigned DN
	4	Brown-White	X02	-Rx	003-004	Assigned DN
	30	White-Slate	X03	+Tx	005-006	Assigned DN
	5	Slate-White	X03	-Tx	005-006	Assigned DN
	31	Red-Blue	X03	+Rx	005-006	Assigned DN
	6	Blue-Red	X03	-Rx	005-006	Assigned DN
	32	Red-Orange	X04	+Tx	007-008	Assigned DN
	7	Orange-Red	X04	-Tx	007-008	Assigned DN
	33	Red-Green	X04	+Rx	007-008	Assigned DN
	8	Green-Red	X04	-Rx	007-008	Assigned DN
Slot 2	34	Red-Brown	X05	+Tx	009-010	Assigned DN
	9	Brown-Red	X05	-Tx	009-010	Assigned DN
	35	Red-Slate	X05	+Rx	009-010	Assigned DN
	10	Slate-Red	X05	-Rx	009-010	Assigned DN
	36	Black-Blue	X06	+Tx	011-012	Assigned DN
	11	Blue-Black	X06	-Tx	011-012	Assigned DN
	37	Black-Orange	X06	+Rx	011-012	Assigned DN
	12	Orange-Black	X06	-Rx	011-012	Assigned DN
	38	Black-Green	X07	+Tx	013-014	Assigned DN
	13	Green-Black	X07	-Tx	013-014	Assigned DN
	39	Black-Brown	X07	+Rx	013-014	Assigned DN
	14	Brown-Black	X07	-Rx	013-014	Assigned DN
	40	Black-Slate	X08	+Tx	015-016	Assigned DN
	15	Slate-Black	X08	-Tx	015-016	Assigned DN
	41	Yellow-Blue	X08	+Rx	015-016	Assigned DN
	16	Blue-Yellow	X08	-Rx	015-016	Assigned DN

Trunk Module with BRI-ST cartridge (Continued)

TC slot	Pin	Wire color	Port (loop)	Service	Lines (T or S loop)	Terminal equipment (S loop)	
Slot 3	42	Yellow-Orange	X09	+Tx	017-018	Assigned DN	
	17	Orange-Yellow	X09	-Tx	017-018	Assigned DN	
	43	Yellow-Green	X09	+Rx	017-018	Assigned DN	
	18	Green-Yellow	X09	-Rx	017-018	Assigned DN	
	44	Yellow-Brown	X10	+Tx	019-020	Assigned DN	
	19	Brown-Yellow	X10	-Tx	019-020	Assigned DN	
	45	Yellow-Slate	X10	+Rx	019-020	Assigned DN	
	20	Slate-Yellow	X10	-Rx	019-020	Assigned DN	
	46	Violet-Blue	X11	+Tx	021-022	Assigned DN	
	21	Blue-Violet	X11	-Tx	021-022	Assigned DN	
	47	Violet-Orange	X11	+Rx	021-022	Assigned DN	
	22	Orange-Violet	X11	-Rx	021-022	Assigned DN	
	48	Violet-Green	X12	+Tx	023-024	Assigned DN	
	23	Green-Violet	X12	-Tx	023-024	Assigned DN	
	49	Violet-Brown	X12	+Rx	023-024	Assigned DN	
	24	Brown-Violet	X12	-Rx	023-024	Assigned DN	
	50	Violet-Slate	----		reserved	----	----
	25	Slate-Violet	----		reserved	----	----

To determine the assigned lines for a BRI card, refer to BRI and T1 lines on page 522.
For an explanation of port numbering, see Port numbering on the wiring charts on page 241.

Trunk Module with BRI-U cartridge

TC slot	Pin	Wire color	Port (loop)	Service	Lines (U-NT)	Terminal equipment (U-LT)
Slot 1	26	White-Blue	X01	T	001-002	Assigned DN
	1	Blue-White	X01	R	001-002	Assigned DN
	27	White-Orange	X02	T	003-004	Assigned DN
	2	Orange-White	X02	R	003-004	Assigned DN
	28	White-Green	----	----	----	----
	3	Green-White	----	----	----	----
	29	White-Brown	----	----	----	----
	4	Brown-White	----	----	----	----
	30	White-Slate	X03	T	005-006	Assigned DN
	5	Slate-White	X03	R	005-006	Assigned DN
	31	Red-Blue	X04	T	007-008	Assigned DN
	6	Blue-Red	X04	R	007-008	Assigned DN
	32	Red-Orange	----	----	----	----

TC slot	Pin	Wire color	Port (loop)	Service	Lines (U-NT)	Terminal equipment (U-LT)
	7	Orange-Red	----	----	----	----
	33	Red-Green	----	----	----	----
	8	Green-Red	----	----	----	----
Slot 2	34	Red-Brown	X05	T	009-010	Assigned DN
	9	Brown-Red	X05	R	009-010	Assigned DN
	35	Red-Slate	X06	T	011-012	Assigned DN
	10	Slate-Red	X06	R	011-012	Assigned DN
	36	Black-Blue	----	----	----	----
	11	Blue-Black	----	----	----	----
	37	Black-Orange	----	----	----	----
	12	Orange-Black	----	----	----	----
	38	Black-Green	X07	T	013-014	Assigned DN
	13	Green-Black	X07	R	013-014	Assigned DN
	39	Black-Brown	X08	T	015-016	Assigned DN
	14	Brown-Black	X08	R	015-016	Assigned DN
	40	Black-Slate	----	----	----	----
	15	Slate-Black	----	----	----	----
	41	Yellow-Blue	----	----	----	----
	16	Blue-Yellow	----	----	----	----
Slot 3	42	Yellow-Orange	X09	T	017-018	Assigned DN
	17	Orange-Yellow	X09	R	017-018	Assigned DN
	43	Yellow-Green	X10	T	019-020	Assigned DN
	18	Green-Yellow	X10	R	019-020	Assigned DN
	44	Yellow-Brown	----	----	----	----
	19	Brown-Yellow	----	----	----	----
Slot 3	45	Yellow-Slate	----	----	----	----
	20	Slate-Yellow	----	----	----	----
	46	Violet-Blue	X11	T	021-022	Assigned DN
	21	Blue-Violet	X11	R	021-022	Assigned DN
	47	Violet-Orange	X12	T	023-024	Assigned DN
	22	Orange-Violet	X12	R	023-024	Assigned DN
	48	Violet-Green	----	----	----	---
	23	Green-Violet	----	----	----	---
	49	Violet-Brown	----	----	----	---
	24	Brown-Violet	----	----	----	---
	50	Violet-Slate	----	reserved	----	---
	25	Slate-Violet	----	reserved	----	---

BRI U wiring is not polarity sensitive.

A BRI-U2 Card only uses the first two loop numbers (X01-X02, X05-X06, or X09-X10) when it occupies a trunk module slot.

Emergency telephone

You can connect an emergency telephone to an ICS or Trunk Module (TM) with a Loop Start Trunk Cartridge to provide emergency service when there is no power to the ICS. The ICS has emergency telephone connections for lines 002 and 026. Each Trunk Module has one emergency telephone connection.

1. Wire a modular jack or equivalent to each set of emergency telephone pins on the 50-pin distribution block for the ICS or Trunk Module external lines. Refer to *Wiring charts* on page 241 for the pin numbers.
2. Connect a single-line telephone (500/2500) to the modular jack.
3. Prepare to test the emergency telephone by removing the Trunk Cartridge from the slot (slot 3 or 4 on the ICS, and slot 1 on the TM).
4. Connect the power, then connect the central office lines to the ICS.
5. Pick up the emergency telephone receiver and listen for dial tone.
6. Disconnect the central office lines, then remove power from the system.
7. Replace the Trunk Cartridge in the left slot.
8. Continue with procedures for powering up the system.



Tips - *The emergency telephone connections on the Trunk Module will not work if there is an E&M/DISA, a BRI-ST or BRI-U card or a DID Trunk Cartridge in the first slot of the Trunk Module. The emergency telephone connections on the ICS will not work if DTIs or PRIs are used.*



Tips - *Norstar telephones and Business Series Terminals cannot be used as off-premise telephones (OPX). For OPX applications, use the Norstar Analog Terminal Adapter (ATA2) and a single-line telephone. Refer to the ATA Installation Card for details.*

Moving telephones

You can move a system telephone to a new location within the Norstar system without losing the programmed settings.

When `Set relocation` is enabled in system programming, the internal numbers, autodial settings, and personal speed dial codes remain with the telephone when it is unplugged.

To move a telephone, simply unplug it and plug it in again at another location. It may take up to 45 seconds for the ICS to recognize the telephone. Automatic telephone relocation is disabled by default.



Tips - *Relocate the disconnected system telephone before connecting a new telephone into the jack. This allows the moved telephone to retain the programmed settings.*

If a new telephone is plugged into the jack before the old telephone is reconnected at a new location, Norstar will give the current telephone information to the new telephone. The old telephone will no longer be recognized by the system.

When reprogramming the internal number of a telephone, wait one minute after Automatic Telephone Relocation.

When you relocate a telephone, the telephone must remain installed and connected in the new location for at least three minutes for the programming relocation to be complete. Moving the telephone again before the three-minute period may result in losing the programming on the telephone.

Installing ISDN BRI terminal equipment

For each S or T or U-LT reference point, an eight-position miniature unkeyed plug from the terminal equipment (TE) is plugged into a jack connected to Norstar wiring. The pin connections for the jack and plug are shown in the following charts.

S or T wiring for terminal equipment

Pin (jack or plug)	Norstar connection (for jack)	Equipment connection (plug)
1	not used	optional power source 3 (+)
2	not used	optional power source 3 (-)
3	+Rx	+Rx
4	+Tx	+Tx
5	-Tx	-Tx
6	-Rx	-Rx
7	not used	optional power sink 2 (-)
8	not used	optional power sink 2 (+)

S or T extension wiring configurations

The last connection on any ISDN S or T extension wiring must have terminating resistors to ensure correct timing of the signaling circuits. Failure to install terminating resistors will degrade performance. Terminating resistors should not be connected on a TE which is not the last connection on the loop.

Terminating resistors are provided on terminal equipment. See the instructions that come with your TE for information on how to enable or disable the termination, as required.

The maximum length of spur and ISDN connection cord (the extension from the main line or bus) is 10 m (30 ft).

Refer to *S reference point* on page 51 and *T reference points* on page 51 in the *Welcome to ISDN* chapter for information about wiring arrangements for ISDN terminal equipment (TE) on an S or T loop.

Additional power

A Norstar S or T-loop does not provide power on Power Source 1 (PS1), Power Source (PS2), or Power Source or Sink 3 (PS3). If you are installing ISDN terminal equipment at the S-reference point, and the equipment requires additional power on PS1, PS2, or PS3, then you can install a suitably approved power supply unit. See ANSI T1.605 or the documentation that comes with your TE for details.

The Modular ICS does not require power on PS3.

Wiring arrangements using side circuits, also called phantom circuits, may affect loop performance when they are used to provide power to the TE (PS1). You must account for any effects. For example, you may need to reduce the number of TEs on a passive bus.

U-LT wiring for terminal equipment

Pin (jack or plug)	Norstar connection (for jack)	Equipment connection (plug)
1	not used	optional battery status indication (+)
2	not used	optional battery status indication (-)
3	not used	no connection
4	R	R
5	T	T
6	not used	no connection
7	not used	optional power (-)
8	not used	optional power (+)

No power supply is provided for the U-LT wiring. If equipment attached to the U-LT loop requires optional power, install an approved power supply unit. See ANSI T1.601-1992 Annex H or the documentation that comes with your TE for more information.

Jack and plug pin numbering

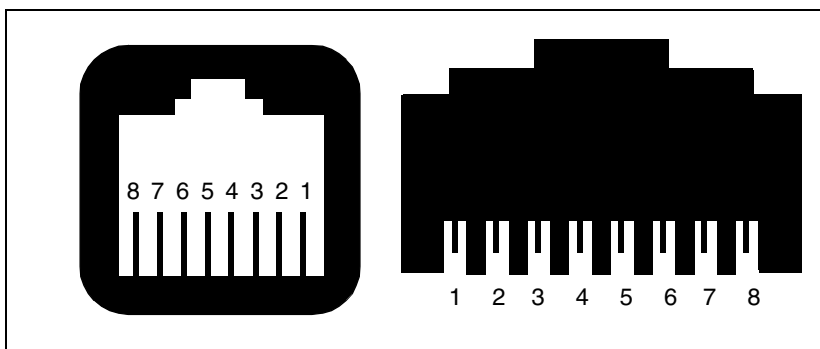

Installing optional equipment

This section describes the installation procedures for optional, customer-supplied equipment.

Auxiliary ringer (customer supplied)

The Norstar ICS provides a control contact to operate an auxiliary ringer.

1. Follow the installation instructions provided by the manufacturer.
2. Connect the auxiliary ring generator to the 50-pin distribution block as shown in the wiring charts.

The pins in this chart provide a control contact. They do not provide ring current or DC voltage. The ringer must not draw more than 50 mA from a 40 V DC source.



Auxiliary ringer programming

The auxiliary ringer can be activated by setting auxiliary ring for specific external lines, and auxiliary ring for specific telephones. Refer to the *Modular ICS 6.0 System Coordinator Guide* for programming details.

Heading
Trk/Line Data
Capabilities
Services

External music source (customer supplied)

The music source can be any approved low-power device such as a radio with a high-impedance earphone jack. The recommended ICS input level is 0.25 V rms across an input impedance of 3300 Ω .

1. Connect the music source output to the 50-pin distribution block, as shown in the wiring charts.
2. Adjust the volume of the music source to a comfortable level by activating Background Music (  ) and adjusting the volume at the music source.



Tips - *Background Music volume can also be adjusted at each telephone.*

External music source programming

Music for callers on Hold and for Background Music must be enabled through programming. Refer to *Backgrnd music* on page 397 for more details.

Confirm that the following settings are implemented:

Heading	Setting
Featr settings	On hold: Music
Featr settings	Backgrnd music: Y

External paging system (customer supplied)

You can connect an external paging system to provide paging over external loudspeakers. The paging output from the Norstar ICS is 100 mV rms across an input impedance of 600 Ω .

1. Follow the installation instructions provided by the manufacturer.
2. Connect the paging system audio input to the 50-pin distribution block as shown in the wiring charts.
3. Connect the paging system relay to the 50-pin distribution block as shown in the wiring charts.

External paging contacts

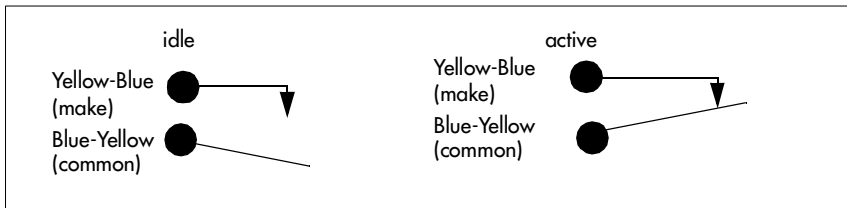

Tips - *Norstar external paging does not support talk-back paging equipment unless an external line port is used.*

The Norstar system provides paging over the Norstar telephone speakers, even when no external paging equipment is connected.

Powering up the system

1. Double-check all wiring before turning the system power on. Ensure all outlets where you will plug in the modules are non-switchable, third-wire ground AC outlets.



Do not connect central office line cables to the modules until after the system power is on.

2. Route the module power cords through the lower shelf of the cable trough and out through the bottom of the ICS cable trough.
3. Route the ICS power cord through the bottom of the ICS cable trough.



Companion: Install Base Stations before powering up the MICS-XC 6.0 system.

4. Connect each power cord to an electrical outlet.

If you are using a power bar, plug the power cords into the power bar, and then connect the power bar to the AC outlet.



Do not fasten power supply cords.

Do not fasten the ICS power supply cord or module power supply cords to any building surface, including the backboard.



Close and lock the ICS door.

Close and lock the ICS door after installation is complete to avoid accidental shock and to provide containment in the event of fire.

Check the power

After the power is supplied, the ICS power supply LEDs will light up green. If a BRI cartridge is installed, the LEDs on the faceplate of the cartridge will flash for up to five minutes. Telephones and lines also may take up to five minutes to initialize.

1. Check that the power LEDs of the power supply, the TMs, and the SMs are on.
2. If none of the LEDs are on, verify that power is present at the outlet. If there is power at the outlet, see *Problems for network or remote users* on page 576.



Tips - *During system initialization, the system performs a self-diagnostic test on the hardware configuration size and expansion cartridge installation.*

Once the system is initialized and the telephone displays read **Jan 1 1:00 am**, you have 15 minutes in which to perform Profile, Dialpad, and Startup programming. After 15 minutes, access to Startup programming is denied.



Tips - *After system startup, you can turn the power off and on and retain any system data that has been entered. This is considered a warm start. A warm start takes approximately 5-10 minutes. However, if you run Startup again, the default programming will be reestablished.*



Call Log information may be lost.

If the Norstar system suffers a power failure or the system is manually restarted, Call Log information is not saved. Notify users if a system restart is planned so any log information can be written down first.

System power indicators

ICS LED (green)

TM LED (red)

SM LED (red)

IDM LED (green)

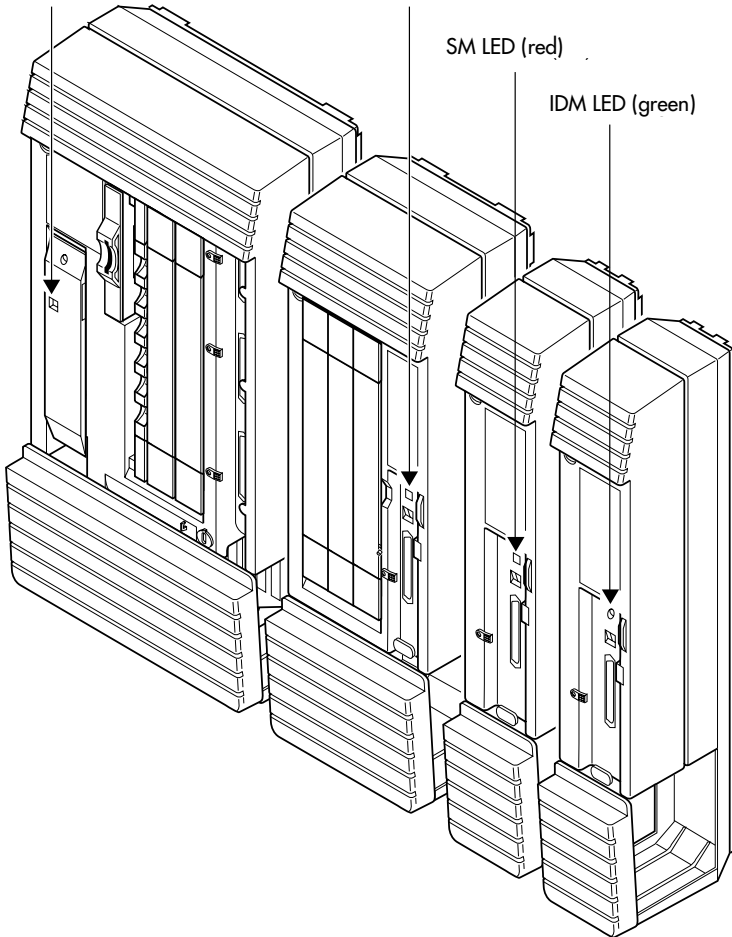

Programming

The installer or the customer service representative programs settings for the entire Norstar system, plus settings for individual telephones and external lines.

Most of the settings can also be programmed by a system coordinator who has a SysCoord+ password. The SysCoord+ password should only be used by individuals who are capable of programming the Norstar ICS. Further, this level of access should only be distributed to System Coordinators who are more experienced in programming the Norstar ICS.



Programming affects system operation.

Only a qualified installer or customer service representative should perform startup, installation and maintenance programming. Some of the settings affect the correct operation of the system.

Programming overview

Programming access is controlled by these passwords.

- Profile password — allows you to determine the system profile. The default profile is the profile used for North American applications.
- Dialpad password — allows you to determine the style of dialpad programming for your system. This setting determines which key you press to obtain the letters Q and Z. The default is non_CCITT (press 0 for both letters).
- Installer password — allows you to determine the defaults you will use as the basis for your system programming. It also allows you to view these settings and change them, as required for your system requirements.
- System Coordinator Plus password — provides knowledgeable users with access to all but a few sensitive areas of programming. You should only distribute this password to experienced System Coordinators.
- System Coordinator password — allows an administrator responsible for the day-to-day operation privileges to view and change the settings that affect on-going operations. This level of access is documented in the *Modular ICS 6.0 System Coordinator Guide*.
- Basic password – provides a limited number of feature codes to change programming and control system services.

For information about programming using the System Coordinator and Basic passwords, see the *Modular ICS 6.0 System Coordinator Guide*.

The tables in this section provide an overview of what programming is seen by each type of user. For information about changing the passwords, see *Passwords* on page 382.

If you are new to programming, you may want to practice using the step-by-step programming instructions in the *Getting Started* section of the *Modular ICS 6.0 System Coordinator Guide* before attempting other programming.

Profile, Dialpad and Startup programming

Profile: (**7763453)

Dialpad: (**3425723)

Startup: (**7827887)

Default password: (266344)

Profile	
Password: (CONFIG)	
Region: PROF1	CHANGE
OK	

Dialpad	
Password: (CONFIG)	
QZ:0	CHANGE

Startup	
Password: (CONFIG)	
Reset Memory?	YES
Template:	CHANGE
Start DN: 2221	CHANGE
Applying Template (Install is complete when Date and Time appears on the display)	

Installer or System Coordinator Plus programming

Entry code: (**266344)

Installer password: (266344)

System Coordinator Plus password: (727587)

Startup	Passwords	Telco features
Template	COS pswds	VMsg ctr tel#s
Start DN	Call log pswds	ONN blocking
Terminals&Sets	Progrming pswds	Software keys
Line access	Reg. pswd	SysID
Capabilities	Hospitality	Password keys
Name		Hardware
User preferences	Time&Date	Cards on KSU
Restrictions	System prgrming	Mod 03 - Mod 14 (depending on type of system)
Telco features	Hunt groups	Maintenance
Lines	Change DN's	System version
Trunk/Line data	Featr settings	Port/DN status
Name	Direct-dial	Module status
Restrictions	CAP assignment	Sys test log
Telco features	Dialing Plan	
Services	Access codes	Sys admin log
Ringing service	Remote access	Network evt log
Restrn service	Change DN type	Provisioning
Routing service	Companion	Tests
	Rec'd # length	CSU stats
Common settings	DN length	Diagnostic tools
Sys speed dial	BusName	Link status
	CbC limits	Usage metrics
	Release reasons	Hunt groups
	Hospitality	Call-by-Call
	Network Services	

Shaded items are seen only if you are using the Installer password. Note: As well, some headings will not appear unless the appropriate software code has been entered, for instance Network Services requires the PRI and MCDN software codes. Other settings will not appear unless the appropriate cards or trunks are assigned. CbC headings, for instance, do

not appear unless the NI-2 protocol is used on the DTI trunk card.

Yellow areas are only available with MICS-XC software. These headings provide programming access for the Companion wireless setup.

System Coordinator programming

User code: (**8737)

Default System Coordinator password: (23646)

Terminals&Sets	Services	Reg. pswd
Capabilities	Ringin service	Hospitality
Name	Restrn service	Time&Date
User preferences	Routing service	System prgrming
Restrictions	Sys speed dial	Hunt Groups
Telco features	Passwords	Companion
Lines	Call log pswds	BusName
Name	Progrming pswds	Hospitality

Admin/Basic programming

User code: (**8737)

Default Basic password: (22742)











Set ####	
Model	Language
Button prgming	Display cntrst
User speed dial	Ring Type
Call log opt'ns	Voice path
Dialing opt'ns	

Programming tools

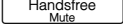
This section describes how to set up a telephone for system programming.

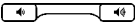
You will note that two different sheets of programming overlays came with your *Programming Record*. Use the one that was created for the telephone you plan to use to program your system.

You can use a T7316 Business Series Terminal or an M7310 or M7324 telephone for programming. These telephones have two-line displays. Use the appropriate template and refer to the table below for corresponding button faces:

Business Series Terminals T7100, T7208, T7316, T7406	Button description	Norstar sets M7100, M7208, M7310, M7324
	Feature	
T7208 and T7316: Handsfree:  Mute: 	Handsfree/Mute	
	Hold	
	Volume Control	
	Release	

The programming overlay

The programming overlay is a paper cutout that labels the four telephone buttons used during programming. You received two pages of overlays with your *Programming Record*. One page corresponds to the Business Series Terminals T7316 telephone. The second sheet corresponds to the Norstar M7310 and M7324 telephones.

Remove the appropriate overlay from the page and put it over the buttons indicated in the following diagrams.

Business Series Terminal T7316 with overlay

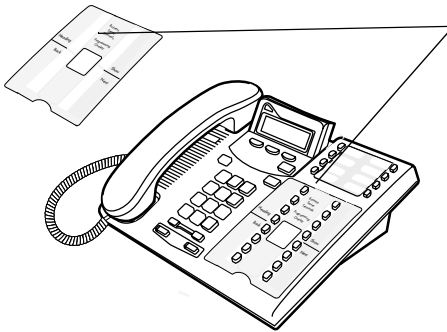

Place overlay
over bottom set of
memory buttons

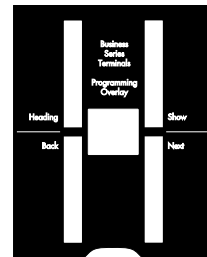

Norstar terminals M7310 and 7324 with overlays

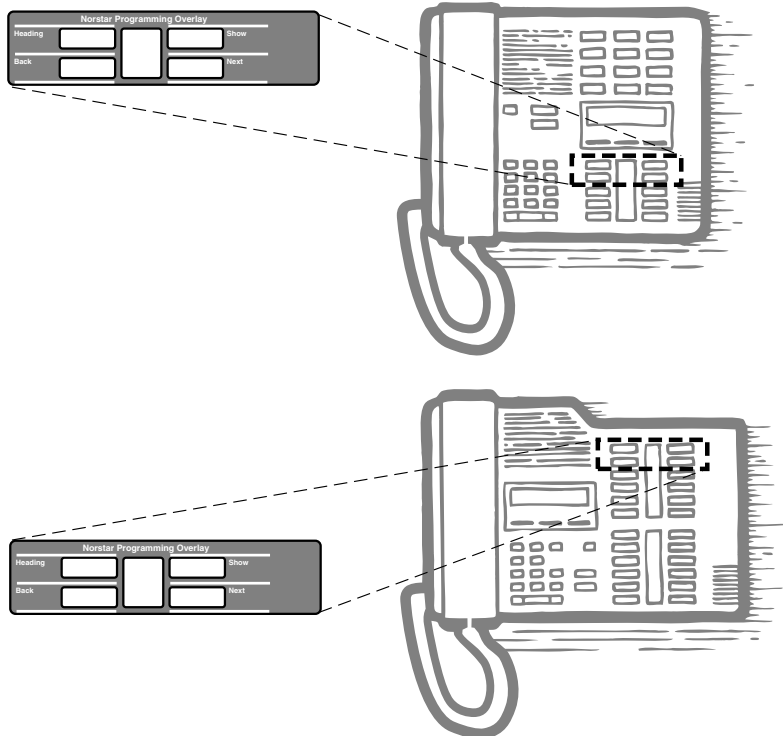

Using the telephone buttons for programming

On the overlay, each of the four programming buttons is assigned a action feature.

The indicators (▶) on the display beside the buttons show which buttons are active at each programming step. Press the appropriate button to move up or down through the Norstar programming menu.

The table below describes the action of each button.

Telephone overlay button definitions

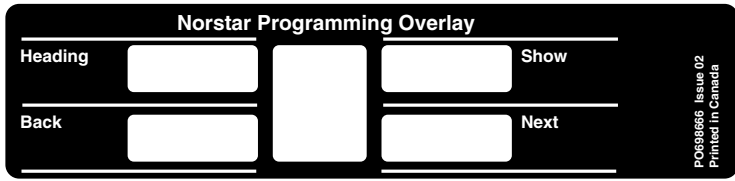

- moves to a higher level in the hierarchy of headings and subheadings.
- moves to a lower level in the hierarchy of headings and subheadings, or begins programming for a heading or subheading.
- moves backward at the same level in the hierarchy of headings and subheadings.
- moves forward at the same level in the hierarchy of headings and subheadings.

Special characters on the display

When a heading ends with a triangle (▸), you can press

to view the subheadings for that item.

When a heading ends with an ellipsis (...), you can press

to see further information about that heading.

The display buttons

Display buttons on the telephones perform a number of functions, depending on where you are in programming. Up to three display button messages may be available at any time.

Press the display button underneath the message for the function you want the system to perform.

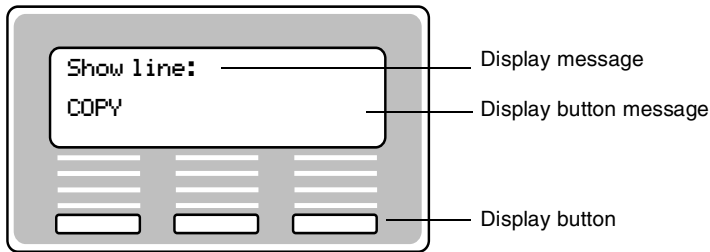

The most common display button labels are described in the following table:

Display button definitions

CHANGE	changes a programmable setting
BKSP	moves the cursor one space to the left (backspace) and deletes a character, allowing you to re-enter a number or letter
COPY	copies the settings of items like lines, telephones and filters to an item of the same type
LIST	displays the lowest value in a list of DNs, lines or other items
FIND	allows you to enter specific code to go directly to a record
VIEW➔	views the last part of a displayed message longer than 16 characters
←VIEW	views the first part of a displayed message longer than 16 characters
>	moves the cursor one position to the right when programming a name
<	moves the cursor one position to the left when programming a name
OK	confirms the change you made, or accepts the default, if you made no changes
ANY	Enters a wild card character that represents any digit between 1 and 9.

The Norstar Programming Record

The *Programming Record* can be used to help you plan your programming strategy. If you enter all your settings on the tables provided, you create a quick reference guide to your system.

Pages from the record may be photocopied, as necessary, for programming many telephones or lines. Additional Programming Records can also be ordered from your vendor.

Exiting

Norstar stores your changes automatically as soon as you alter any settings. If you changed something in error, you must re-enter the correct data.

In extreme situations, you may have to restart the system and reload with your backup material.

To exit the configuration interface, press . The display briefly reads **End of session**, then returns to the Date and Time display.

Viewing your programming updates

If any changes you made to programming have not taken effect yet, you will see an **UPDATE** display button when you leave programming. The display will show you how many telephones have not been updated yet because the system is busy with other programming or the telephone is in use.

Press **DN5** to see the specific telephones where programming changes have not been updated. Items will disappear from the list as they are updated, and **UPDATE** will disappear once all changes are complete.

Entering numbers

Numbers are entered from the Norstar telephone dialpad. The backspace display button may be used to edit the number.

A line number must always be entered as a three-digit number. Line numbers from 10 to 99 must be entered with a leading zero (line 020, for example). Similarly, line numbers less than 10 must be entered with two leading zeros (line 002, for example).

Internal telephone numbers, also referred to as directory numbers (DNs), can be from three to seven digits long. The default DN length is three. The DN length can be changed in programming.

Viewing long telephone numbers

External telephone numbers can be up to 24 digits, but the telephone display is only 16 character spaces long. To see a previously-programmed number that is longer than 16 digits, do the following:

Begin, for example, with **123456789012345....** The display shows only the first 15 digits. The three dots (...) at the end of the display indicate that more digits remain to the external number.

1. To see the remaining digits, press **VIEW+**.
2. To see the first 15 digits again, press **+VIEW**.

Setting up User Preferences

The User Preferences feature allows you to program memory buttons, speed dial codes, and other settings for any telephone on the system.

For example, an employee may want to have the Do Not Disturb feature programmed onto a memory button or create a speed dial code. Instead of programming from the target telephone, you can program these features from another telephone.

To access User Preferences programming, see instructions in the *Modular ICS 6.0 System Coordinator Guide*.

The following table lists the settings you can adjust.

Subheadings under User Preferences

User preferences
Model
Button prgrming
User speed dial
Call log opt'ns
Dialing opt'ns
Language
Display cntrst
Ring type
Voice path

Copying telephone programming

Copying is done by using **COPY** under **Terminals&Sets**. You can copy programming from one telephone to another telephone, to a range of telephones, or to all telephones.

1. At **Terminals&Sets** ▶, press and enter the internal number (DN) of the telephone from which you wish to copy programming.
2. Press **COPY**.
3. Select what programming will be copied:
 - **SYSTEM** – the system administration programming (system data) of a telephone

OR

- **SYSTEM+USER** – the system administration programming PLUS the programming for a particular telephone (user data)

See the tables starting on page 292 to see which settings will and will not be copied with system and user data.

4. Press , then **CHANGE** to select the telephone or telephones which will be programmed with the copied data: **SINGLE, RANGE, ALL**.

You can copy programming to telephones which are not yet hooked up to the system (unequipped).

5. Press , then **CHANGE** to select which telephones will be programmed: **Only equipped DNs, All set DNs**. This is not necessary when copying to a single telephone.
6. Press and enter the internal number of the telephone that will be programmed or the internal numbers of the first and last telephone in a range.

7. Press **OK** to proceed with the copy. This step is not necessary when you are copying to a single telephone.

You can also use **COPY** to duplicate the settings found in the individual subheadings. The button is available in **Line access**, **Capabilities**, **User preferences**, **Restrictions** and **Telco features** and will copy only the settings included in the subheading.

If you press **COPY** in one of these subheadings, you will not be asked to decide if user data will be copied. Otherwise, the procedure is the same.



Tips - *To copy to a group of telephones which are not part of a range, follow the steps for making a single copy and keep entering new numbers at the **COPY to:** display.*

Depending on the activities going on in the system, a copy may not take effect for a while. The brief display you see once you have finished a copying session does not indicate the process is complete.

You can leave the programming session even if the copy has not been completed. If you exit programming, copying will continue uninterrupted until it is complete.



Tips - *Event messages capture both the start and completion of the copying process. For more information, see [Event messages on page 514](#).*

Some programming settings allow you to choose a delay according to the number of rings. The ring counts used are based on a North American standard of six seconds per ring cycle. The actual delay time may be different for a device other than a Norstar telephone.

System Data that gets copied	System data that is NOT copied
<p>Line access</p> <ul style="list-style-type: none"> • Line assignment • Line pool access • Prime line designation • Number of intercom keys • Answer DN's (unless Answer button DN is same as telephone being copied to) 	<p>Line access</p> <ul style="list-style-type: none"> • Private line appearances
<p>Capabilities</p> <ul style="list-style-type: none"> • Call Forward No Answer (DN + delay + setting) • Call Forward Busy (DN + setting) • DND on busy • Handsfree setting • Handsfree answerback • Pickup group • Paging zone • Paging • Direct-dial (which set is reached by the D-Dial digit) • Priority calling • Hotline • Auxiliary ringer • Allow redirect • Redirect ring • ATA settings (except Use ringback setting) 	<p>Capabilities</p> <ul style="list-style-type: none"> • Set name • Use ringback setting under ATA settings
<p>Telco Features</p> <ul style="list-style-type: none"> • Call Log set (<i>Logging set</i>) • 1stDisplay 	<p>Telco features</p> <ul style="list-style-type: none"> • Log password • Log space
<p>Restrictions</p> <ul style="list-style-type: none"> • Set restrictions • Set lock • Allow Last Number Redial • Allow Saved Number Redial • Allow Link • Line/set restrictions 	<p>Direct-dial set designation (which set is the D-Dial set)</p> <p>CAP assignment</p> <p>ExtraDial set designation</p> <p>Service mode ringing set designation</p> <p>Prime set designation for a line</p> <p>Hunt group appearance</p>

User data that gets copied	User data that is not copied if destination set type is the same as the source set type
Language choice Ring type Calls log options (<i>Auto logging</i>) Display contrast Dialing options (automatic, pre-dial, standard)	External autodial button assignments Internal autodial button assignments Programmable button assignments

Ring volume, User speed dial and CAP module memory button programming are not copied with user data.

System ID

The System ID (or System Security number) can be accessed on a programming terminal display by pressing

* * S Y S I D or * * 7 9 7 4 3 .

Reviewing programmed settings







The Set Profile and Line Profile features help you to check your programming by allowing you to review the settings.

Programming that can be reviewed

Set Profile	Line Profile
Terminals&Sets settings	Lines settings
Set name	Line name
Line Access	Trunk data
Capabilities	Line data
Restrictions	Restrictions
Telco features	Telco features







Viewing the programming for a telephone

To display the programming for a set, follow these steps:

1. Press       .
The display reads **Show set.:**
2. Enter the internal number of the telephone you wish to review.
3. Use **BACK**, **NEXT**, and **SHOW** to navigate through the settings.
4. Press  to exit.

Viewing the programming for a line

To view line programming for a telephone, follow these steps:

1. Press       .
The display reads **Show line.:**
2. Enter the number of the line you wish to review.
3. Use **BACK**, **NEXT**, and **SHOW** to navigate through the settings.
4. Press  to exit.

Programming sequence

The programming information in this guide is presented in the order that is useful for everyday changes and upkeep of the system.

The following order of process is recommended as more suitable for an installation. However, the order in which you program your system will depend on a variety of variables and may differ from this list.

- Profile and Dialpad, if required (page 296 and page 300)
- Startup (initializes system) (page 301)
- Software keys for PRI and MCDN, if required. (page 452)
- Hardware (starting on page 455)
- Lines (including any networks) (starting on page 333)
- Terminals&Sets (starting on page 308)
- System prgrming (starting on page 389)
- Services (starting on page 353)
- Telco features (starting on page 447)
- Other software keys (Companion) (Companion Installer and Coordinator Guides)
- Sys speed dial (starting on page 381)
- Passwords (starting on page 382)
- Time&Date (starting on page page 388)
- customized programming, such as Voice Mail (refer to the documents for the specific application)

Profiles and Dialpads

Use Profile programming to determine which types of trunks are supported, and which are supported on and off core.

Use Dialpad programming to define how your system will handle the letters Q and Z from the dialpad.



You must do this procedure **BEFORE** you run Startup, within the first 15 minutes after you plug in your KSU.

If you run this program after Startup, you will lose your settings.

Profile programming

If your system is outside of North America, you may require a slightly different operating profile for your system. You must choose these parameters before you perform your system startup programming.

If your system is in North America or you know that you want to run that profile, you do not need to run this program.

Profile parameters

Each market profile setting supports a different selection of trunk cards. In your situation you may require NI (primarily North America and some parts of South America) or ETSI (Europe, Asia, and some parts of South America) ISDN. Analog to digital expansion and compression rates can be either a-law or mu-law, as well. The tables in the following sections show which trunks are supported, and where.

Note: If you are unsure of the ISDN protocol or companding law active in your area, consult with your ISDN service provider for details.

Profile 1

This profile is the default profile. It supports cards and protocols for Canada and the United States. This profile has language support for English, Canadian French, and Spanish. The mu-law companding law is used in this profile. The off-core DTI module is supported on this profile.

Profile 2

This profile is for international systems that use ETSI ISDN lines with aLaw. The languages supported include: English, French, Spanish, and Turkish.

Cards supported on-core	Cards supported off-core
<ul style="list-style-type: none"> • Analog • DTI • 4-port BRI-ST • 2-port BRI-ST • PRI (E1) 	<ul style="list-style-type: none"> • Analog • E&M • 4-port BRI-ST • 2-port BRI-ST

Supported	Not supported
<ul style="list-style-type: none"> • ETSI MCDN (SL-1) and EURO protocols • aLaw companding law • Loops are provisioned • T7000 telephone 	<ul style="list-style-type: none"> • DID • UTAM

Profile 3

This profile provides language support in NA English, CDN French, US Spanish, and Turkey. This profile is for countries who use ETSI ISDN with mu-law (i.e. some Asian locations)

Cards supported on-core	Cards supported off-core
<ul style="list-style-type: none"> • Analog • T1 • 4-port BRI-ST • 2-port BRI-ST 	<ul style="list-style-type: none"> • Analog • E&M • DID • 4-port BRI-ST • 2-port BRI-ST
Supported	Not supported
<ul style="list-style-type: none"> • ETSI ISDN protocol • muLaw companding law • Loops are provisioned • T7000 telephone 	<ul style="list-style-type: none"> • PRI • UTAM

Profile 4

This profile provides language support in English, French, and Spanish. This profile is for countries who use NI ISDN protocol with mu-law (i.e. some areas in the Caribbean).

Cards supported on-core	Cards supported off-core
<ul style="list-style-type: none"> • Analog • T1 • PRI • 4-port BRI-ST • 2-port U • 4-port U 	<ul style="list-style-type: none"> • Analog • E&M • DID • 4-port BRI-ST • 2-port U • 4-port U

Supported	Not supported
<ul style="list-style-type: none"> • NI ISD protocol • muLaw companding law • PRI, including MCDN • T7000 telephone 	<ul style="list-style-type: none"> • UTAM • Loops are not provisioned

Changing the profile

If your system is in North America or you know that you want to run the North American profile, you do not need to run this program.



If you need to change the profile, follow these steps:

1. Enter the Profile access code from a programming set by pressing * * P R O F I L E (**7763453).
2. Enter the password, when prompted.
 (266344)
3. **Region:PROF1** displays. Press the key below **Change** to scroll to another profile number.
4. Click the display key for when you reach the profile you want to choose.
5. Press to exit.











Dialpad programming

Use this program to determine how the system will recognize the characters Q and Z from a set dialpad. The two types of configurations are called CCITT and non-CCITT.

The default is non-CCITT, where Q and Z are accessed through the  dialpad button.

CCITT systems access these characters through the  (Q) and  (Z) dialpad keys.

To change the setting, follow these steps:

1. Enter the Dialpad access code from a programming set by pressing           (**3425723).
2. Q,Z:0 displays. To change it, press the key below **Change**.
3. Press  to exit.

Startup programming

After the hardware has been installed and powered up, use Startup to initialize the system, and select the system template that best suits your system.



Startup erases programming.

Startup erases any existing programmed data, and resets the system to factory defaults.



Tip - *Ensure that you have current backups of your system programming and logs.*

All programming is retained for three days if the power fails or if the Norstar system is powered off. After three days, it may be necessary to perform Startup.

Performing Startup

1. Enter the Startup access code from a programming set, by pressing * * S T A R T U P which is the same as * * 7 8 2 7 8 8 7 .

To be accepted, the Startup code must be entered no later than 15 minutes after the Norstar system has been powered up.

If 15 minutes have elapsed since you powered up the system, turn system power off and on and wait for the system to power up again.

2. Enter the Installer password.
The default is which is the same as .



Tips - *The Installer password shown is the default normally used for Startup. For a system which has already been programmed, the Installer password might have been changed in programming and recorded in the Programming Record.*

Changing the default template

After entering the Startup access code and Installer password the set displays **Reset memory?**.

1. Press **YES** to select a default template.
The display shows the current template.
2. Press **CHANGE** to choose the appropriate template.



Changing the template resets programming!

If you change your system template on an existing system, your programming will be reset to the defaults.

If this happens, perform an immediate restore from your backups.

Changing the starting DN

You can change the starting number for your telephone directory numbers (DNs). This is helpful when your system is part of a network and you want to use a uniform series of directory numbers for all telephones in your network.

With the display showing the current template.

1. Press .

The display shows the current start DN.

2. Press **CHANGE**.

3. Enter the new directory number you want as the starting DN, and press **OK**.

The display shows the new range of DN numbers.

4. Press to store the programming.

The display shows **APPLYING template**.

This process takes a few minutes. When it is complete, the indicators begin to flash. When the set displays **Jan 1 1:00 am**, the initialization is complete.



The length of the directory number that you enter sets the length for all directory numbers. Target line received numbers are set to the same length when using the DID template. DNs can be from three to seven digits. If your system is part of a network, the DN length must be the same as all other systems.

A DN length change, if required, should be the first programming change on a newly-installed Norstar system.



Changing the DN length

*If you reduce the length of the directory numbers in **DN length** in **System Programming**, the starting DN number is reset to the default value (221).*

*If you increase the length of directory numbers in **DN length** in **System Programming**, each increase in length places the digit 2 in front of any existing DN. For example, if DN 3444 was increased to a length of 6, the new DN would be 223444.*

If the new DNs clash with the direct-dial digit, park prefix, or line pool codes or destination codes, those numbers are overridden and set to None.

Do not disable or enable ports in Maintenance programming during the first two minutes after Startup programming.

Programming

When Startup is complete, use programming to change default settings, as required. Use the programming record to orient yourself within the programming menus.

Programming for both MICS 6.0 and MICS-XC 6.0 has the following main headings:

Terminals&Sets	Allows you to assign settings to each telephone.
Lines	Allows you to assign settings to each trunk, external and target line.
Services	Allows you to create services such as night ringing, routing and restrictions for making external calls.
Sys speed dial	Allows you to create speed dial codes that can be used by any telephone in the system.
Passwords	Allows you to view and change passwords for programming and features.
Time&Date	Allows you to set the time and date on the system clock.
System prgrming	Allows you to change system-wide settings.
Telco features	Allows you to assign settings for external voice message services.
Software keys*	Allows you to access system identification and password keys. Allows you to enter the software keys to activate PRI, Companion (MICS-XC, only), or the Private Networking (MCDN)

Hardware	Allows you to configure the Trunk Cartridges and BRI cards used by the system.
Maintenance	Allows you to view diagnostic information about the system and provision BRI cartridges.
Usage metrics	Provides statistical information on Hunt groups.

*For information about programming for Companion, see the *Modular ICS Companion Installer Guide*.

Entering programming for installers

1. Enter the installer codes on a programming set by pressing

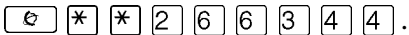
,
which is the same as .

The display shows **Password:**.

2. Enter the Installer password.

The default password is **CONFIG** (266344).

The display shows **Terminals&Sets**. Three triangular indicators ► appear on the vertical display between the rows of buttons.

3. Place the programming overlay over the buttons pointed to by the indicators ►.

Entering programming for system coordinators

The person on staff who is in charge of making changes on the Norstar system is called the system coordinator. The everyday programming done by system coordinators is described in the *Modular ICS 6.0 System Coordinator Guide*.

Some system coordinators need to be able to program more advanced settings and functions in order to carry out the day-to-day requests and upkeep of the Norstar. These coordinators are usually dedicated communications specialists who work with large Norstar systems or other telephone systems like PBX or Centrex.

By using a special password, a system coordinator can see and change many, but not all, of the programming settings used by an installer. In this guide, programming that can only be changed by an installer is marked in the heading. If you are programming using the System Coordinator + password, you will not see these items when you move through the menus. This level of access is documented in the *Modular ICS 6.0 System Coordinator Guide*.

1. Enter the System Coordinator plus codes on a programming set by pressing

, which is the same as
 .

The display shows **Password:**.

2. Enter the System Coordinator + password.

The default password is **SCPLUS (727587)**.

The display shows **Terminals&Sets ▶**. Three triangular indicators ▶ appear on the vertical display between the rows of buttons.

3. Place the programming overlay over the buttons pointed to by the indicators ▶.

Entering programming using other passwords

A set of the most often-used headings and subheadings is available by using a System Coordinator password. Refer to page 281. This level of access is designed for the average user who takes care of the day-to-day changes to the Norstar system, but who is not interested in more advanced programming. The default password is **ADMIN** (23646).

There is also a Basic password that can be used to perform a few programming tasks. The default password is **BASIC** (22742). By using this password, a system coordinator can delegate some responsibilities while keeping secure more sensitive programming features. For more information, refer to *Modular ICS 6.0 System Coordinator Guide*.

Terminals&Sets

Terminals&Sets allows you to assign settings to each telephone.

This is the first heading that appears after you enter your password.

1. Press .

The prompt displays: **Show set:**

2. Enter the set number of the telephone you would like to program.
3. Press **COPY** to duplicate the programming for the telephone and apply it to another telephone, a range of telephones or all the telephones on the system.

For more information about copying set programming, refer to *Copying telephone programming* on page 290.

Line access

Line access allows you to assign lines to individual telephones. When you are finished programming Line access settings for one telephone, you can copy those settings to other telephones.

In some cases, Line access programming for Norstar Companion portables works differently than it does for desk sets. See the *Modular ICS Companion Installer Guide* for information.

PRI lines can only be configured as direct inward dialing (DID) lines. Therefore, PRI lines are always Auto Answer and cannot be Manual Answer.



Tip - When you assign line access for BRI loops which have only one SPID, make sure that the programming for the two lines on a BRI loop is identical. For example, if line 001 on BRI loop 201 appears at a DN, line 002 on the same loop should appear at the DN as well. See the ISDN chapter for more information about programming BRI lines.

In general, auto-answer loop start trunks and auto-answer BRI trunks are not assigned to telephones. If assigned, they are used for monitoring incoming call usage, or for making outgoing calls.

Line assignment

This setting allows you to assign physical trunks and target lines to each telephone. Target lines are assigned and removed in the same manner as other lines.

1. After you have chosen a set number, press and enter the line number.
2. Press **CHANGE** to change the setting for each line to one of the following: **Unassigned**, Ring only, Appr&Ring, and Appr only.

Sets that are grouped together, and that are assigned multiple target lines, can be set to allow ringing at all sets simultaneously (Broadcast ring).

Appearances

This setting only applies for direct inward dial (DID) digits mapped onto target lines.”

The Norstar system can handle simultaneous calls to a set with multiple target line appearances (157 to 284 for MICS, 157 to 348 for XC). The number of target line appearances depends on the line assignment setting, which include: Appr&Ring, Ring only, and Appr only.

If Appr&Ring or Appr only is chosen, you can have as many simultaneous DID calls as there are target line key appearances. If Ring only is chosen, you can have as many simultaneous DID calls as you have intercom keys.



Users cannot access PRI lines directly through line appearances or line pools. All outgoing PRI calls are dialed via intercom using routing codes.

When a trunk card is changed to PRI, all existing line appearances for that card are automatically removed.

The Basic Set, ATA2, portable and BRI ISDN S-terminals cannot process more than two simultaneous calls.

There is a suggested limit of four keys per set. You can program more than four keys on an set by programming less than four on other sets. For instance, you might program 20 keys on a receptionist set equipped with a CAP and only three keys on the 20 sets connected to the CAP.

1. Enter the line number. The display shows the line number and its assignment.
2. Press until the display shows Appearances:1.

3. Press **CHANGE** and enter the number of target line appearances.
4. Press  to exit or to continue programming.



Tips - Press **SCAN** to view the lines assigned to this telephone.

In general, auto-answer loop start trunks, auto-answer E&M trunks and DID trunks are not assigned to telephones. If assigned, they are used for monitoring incoming call usage, or for making outgoing calls (auto-answer loop start and E&M trunks).

In general, fixed data channel trunks are not assigned to telephones. If assigned, they are used for monitoring call usage.

You cannot assign a line that is private to another telephone.

Each line assigned to appear at a telephone must appear at a button with an indicator on that telephone. The maximum number of line buttons are eight for the M7208 telephone and T7208 Business Series Terminal, 10 for the M7310 telephone and T7316 Business Series Terminal, and 24 for the M7324 telephone.

If you set a line to Ring only, incoming calls appear on an intercom button.

A central answering position (CAP), with one or two CAP modules, can provide extra line buttons if more than 24 lines are assigned to the CAP. The remaining lines appear at buttons on the CAP module. This option is only available on the M7324 telephone



Tips - *The M7100 and T700 sets have no line buttons and can be assigned any number of lines. Ensure that the lines assigned to these sets are assigned to ring; otherwise, you cannot detect incoming calls on the lines.*

Line pool access

This setting allows a telephone to access one or more of the 15 line pools available (A to O). When you assign a given line pool, the telephone being programmed can access any lines in that line pool.

Press , then press to scroll through the settings and display the line pool you want to program access to. Press **CHANGE** to select the setting: **N** (No) and **Y** (Yes).

Four exclusive line pools are available for PRI lines for profiles 1 and 4, which support two on-core DTI cards and one off-core DTI card (*Off-core DTI card* on page 201). There can be a maximum of two on-core DTI cards (PRI) on a Norstar system, regardless of profile. The four possible line pools are PRI-A, PRI-B, PRI-C, or PRI-D.

Profiles 2 and 3 only support PRI line pool A and B.

- Only PRI lines can belong to a PRI pool. PRI lines cannot belong to Line Pools A through O.
- All lines on a single DTI card (PRI) belong to the same pool.
- Lines from multiple DTI cards (PRI) can belong to the same pool if they are configured with the same protocol.
- PRI lines are assigned to pools with the **Line type** setting.

Prime line

This setting assigns a prime line to the telephone. A prime line is the first line that is automatically selected when the handset is lifted.

Press **CHANGE** to select one of these settings: None, Pool (A to O), or **I/C** (intercom). Only assigned lines and line pools appear.

PRI pools are not valid selections for a Prime line.



Tips - *An assigned prime line is not associated with the assignment of a prime telephone.*

- *An external line must be assigned to the telephone in Line assignment before it can be assigned as the prime line to the telephone.*
- *A line pool must be assigned to the telephone in line pool access before a line pool can be assigned as the prime line to the telephone.*
- *A target line cannot be a prime line for a telephone because it is incoming-only.*
- *A DID line should not be assigned as the prime line for a telephone. If assigned, it is treated as if no prime line has been assigned. The message **Select a line** appears when the receiver is lifted.*

Remember that if you set prime line to I/C (intercom), you may wish to assign loop start lines to the first line pools. When the system searches for an outgoing line, it begins at line pool A and chooses the first available line.

*By assigning a line pool as a prime line, a telephone can be made to search automatically for an idle line in a pool. This is described in the section on programming Line type (**Trk** Line Data).*

Intercom keys

This setting assigns the number of intercom buttons to a telephone. Intercom buttons provide a telephone with access to internal lines and line pools.

Press **CHANGE** to select the setting: 0, 1, **2**, 3, 4, 5, 6, 7, or 8.



Tips - *Each intercom button assigned during programming automatically appears on the telephone. The buttons start with the lower right-hand button, or one button above if the Handsfree/Mute feature is assigned to the telephone.*

A telephone needs two intercom buttons to be able to establish a conference call with two other Norstar telephones.

Only one intercom button may be required if the button will only be used to make and receive internal calls, and to access line pools.

Two intercom buttons are required if a telephone has several lines assigned to ring only.

The M7100 and T7100 sets default assignment of two Intercom buttons be changed to up to eight buttons. These buttons do not appear on the telephone.

Answer DN's

Calls for other Norstar telephones or Business Series Terminals can appear and be answered at the telephone being programmed. The DN's of the other telephones are referred to as Answer DN's.

This is commonly used when twinning Companion cordless handsets to allow mobile users to have one phone number that reaches them either at their desk or elsewhere within radio range.

1. Press and enter the Answer DN.
2. Press **CHANGE** to change the setting for the Answer DN: **Unassigned**, Appr&Ring or Appr only.
3. To assign additional Answer DNs, press , then enter the next Answer DN.



Tips - Press **SCAN** to view the Answer DNs assigned to this telephone.

Every Answer DN assigned to the telephone automatically assigns an Answer button with an indicator to the telephone. These buttons should be labeled accordingly, identifying the telephone with its name or DN.

The maximum number of Answer DNs that can be assigned to a particular set is eight.

More than one telephone can have an Answer button for the same DN. In this way, more than one telephone can provide call alerting and call answering for any calls directed to that DN.

When a call to a Norstar set is received via Call Forwarding, the Answer DN for that set will not alert.

OLI

Some ISDN devices may require the network Called Number digits, called the outgoing line identification (OLI), to be able to accept a call. The **OLI as called #** parameter permits the OLI digits to replace the internal DN digits of the ISDN device during call setup. To enable this capability, set the **OLI as called #** parameter to **Y** for all DNs used by the device.

1. At **Terminals&Sets**, press and enter the ISDN set number.

The set displays 221:221.

2. Press twice to reach Line Assignment.

3. Press until the display shows **OLI as called #N**.
4. Press **CHANGE** to select **Y** to allow for OLI substitution.
5. Press the  button to exit programming.

For PRI, the OLI# is based on the set number. However, when you make an outgoing call on a BRI line, the Call Display information which appears on the telephone you are calling is usually based on the first Network DN associated with the service profile identifier (SPID) and line.

If the SPID and line have more than one Network DN, you can program a DN to use a Network DN other than the first one for the outgoing Call Display information. When you program the alternate Network DN as the 10-digit OLI number, and you make a call using the line associated with the Network DN, the OLI number appears on the telephone you are calling.

If an outgoing call is made using a SPID and line that are not associated with the Network DN number used as the OLI number, the network ignores the number and the default Call Display information is displayed. This is the first or only Network DN associated with the SPID and line.

1. Press **CHANGE** and enter the 10 digits used for the OLI.
2. Press **CLR** to choose **None**.

Note: If your system is equipped with a mixture of digital line cards, program the sets to use line pools when making calls. If line pools are not properly configured, a set may use a line with a network range that does not include the set CLI, causing the network to present an incorrect CLID to the called party.

Capabilities

Settings that control how the system interacts with individual telephones and the calls they receive are found under **Capabilities**. The following table lists these headings. The default settings are shown in bold.

Setting	Description	Options
Fwd no answer		
Fwd to	Redirect all incoming calls when this telephone does not answer.	Enter DN None
Forward delay	Select the number of rings before an unanswered call is forwarded.	2, 3, 4 , 6, 10
Fwd on busy	Redirect all incoming calls when this telephone is busy with another call.	Enter DN None
DND on Busy	Select whether an incoming call rings if the user is already on another call.	Y, N
Handsfree	Select whether Handsfree will be available to a telephone.	Auto, Std (Standard), None
HF answerback	Select whether a user can automatically answer a voice call without lifting the receiver or pressing the Handsfree/Mute button.	Y, N
Pickup grp	Assign this telephone to a pickup group.	None , 1 to 9
Page zone	Assign this telephone to page zone.	None, 1 to 6
Paging	Select whether paging announcements can be made from this telephone.	Y, N
D-Dial	Select whether you can call the Direct-dial telephone from this telephone using the Direct-dial digit.	Set1 to Set5, None
Priority call	Select whether to allow this telephone to interrupt calls or to override Do Not Disturb at another telephone.	Y, N

Setting	Description	Options
Hotline	Select whether a telephone number will be dialed automatically when a user lifts the receiver or presses the button labeled Handsfree/Mute.	Intrnl, Extrnl, None
Intrnl #	Appears if Hotline is Intrnl	Enter DN, None
Extrnl #	Appears if Extrnl	None , <up to 24 digits>
<Extrnl> facility choice	Appears if Hotline is Extrnl and number is specified. Use routing tabl option routes numbers through the Routing Table. Target lines cannot be used as the facility.	Use Prime line Use line: Pool code: Use Routing tabl
Aux. ringer	Select whether an auxiliary ringer (if installed) will ring for incoming calls at this telephone.	Y, N
Allow redirect	Select whether to allow this telephone to redirect its lines.	Y, N
Redirect ring	Select whether a telephone rings briefly when a call on one of its lines is redirected by the Line Redirection feature (☐ 8 ☐ 4).	Y, N
ATA settings		
ATA ans timer	Select the length of delay between the last digit you dial and when the ATA device is ready to receive DTMF tone.	3, 5, 7, 10
ATA use	Select where the ATA can be used.	On site, Off site
ATA dvc	Select the a device code for the telephone or terminal attached to your ATA. This feature enhances ATA telephone connects from an ATA over PRI/BRI lines.	Telephon Modem
MsgIndicate	Select the type of message indicator. When a message is received, Tone sends a Message Tone through the handset and Lamp turns on the Message Lamp.	None , Tone, Lamp

Setting	Description	Options
Intrusion Protect lvl	Determine the level of access this telephone will have to allow the user to break into calls on other telephones in the system (MCDN Break-in feature). To be able to use Break-in, the Protect lvl must be the same or higher than that of the target telephone.	None , Low, Medium, High

For more information, refer to the *Modular ICS 6.0 System Coordinator Guide*.

ATA settings

Analog terminal adapters (ATA or ATA2) are used to connect analog equipment to a digital trunk line. This section describes the settings that are required for setting up the connection.

ATA ans timer

A timer can be used to administer a delay between the last digit you dial on a device connected to an ATA and when the system begins to send out DTMF or modem tones on the outgoing line without capturing and interpreting them.

To change the delay time, press **CHANGE** to select the setting (in seconds): ATA ans timer: 3, 5, 7, or 10.



Tip - To accommodate the device attached to the ATA, you may need to change the delay. If a modem or fax machine is attached to the ATA, you will want to keep the delay short. If a call to a fax machine or modem cannot be connected, try shortening the delay. If an individual is dialing the number for a fax machine or modem, you may want to make the delay a little longer.

ATA use

An ATA can connect to devices that are on your premises or at some other location.

Press CHANGE to select On site or **Off site**.

Note: This setting is only programmable for ATA2. You can change this setting for others, but it has no effect on the programming. Global ATAs are off site and Analog Station Modules are on site.

ATA dvc

Devices connected to the system through an ATA can have connectivity issues over BRI/PRI lines. To alleviate this, you can specify the type of device.

Press CHANGE to select On **telephon** or modem.

MsgIndicate

Select the type of message indicator to be activated when a set on an ASM has a message.

Press CHANGE to select **None**, Tone, or Lamp.

Name

The default name for a telephone is its DN, but it can be changed to any combination of letters and numbers to a maximum length of seven characters.

For more information, refer to the *Modular ICS 6.0 System Coordinator Guide*.

User preferences

Any programming a user can do at a set can also be done through **User Preferences**. In the following table, the default settings are given in bold.

Setting	Description
Model	Allows you to pre-program the model of Norstar set which will use this DN (M7208). Note: M7100 is used for T7100; M7208 is used for T7208, M7310 is used for T7316.
Button prgrming	Allows you to program the buttons with internal and external autodialers and/or programmed feature keys.
User speed dial	Allows you to program user speed dialers (No defaults). (speed dial codes 256 to 279)
Call log opt'ns	Allows you to select how the set will log calls: Log all calls, No autologging, No one answered , or Unanswered by me.
Dialing opt'ns	Allows you to select how the system will dial for this set: Standard dial , Pre-dial or Automatic dial.
Language	Allows you to choose the language that will display on the set. The choices are based on the Profile chosen when the system was set up. Profile 1, 3 and 4: English , French or Spanish. Profile 2: English , French, Spanish and Turkish
Display cntrst	Allows you to adjust the contrast of the display 1, 2, 3, 4 , 5.....9
Ring type	Allows you to select a ring type 1 , 2, 3, 4
Voice path	Allows you to select Handsfree or Headset.

For more information, refer to the *Modular ICS 6.0 System Coordinator Guide*.

Restrictions

Restrictions prevent a user from making certain kinds of calls from a telephone or from lines that are available at the telephone. It also restricts some features.

When you are finished programming restriction settings for one telephone, you can copy those settings to other telephones by using **COPY** at the **Restrictions** ► display.

For ISDN PRI, all line restriction changes are applicable to all lines.

For more information about copying set programming, see *Copying telephone programming* on page 290.

Filters

Restriction filters group call restrictions and overrides in packages that allow you to make restriction assignments to lines and sets with just one package indicator.

In addition to restricting telephone numbers, you can prevent people from entering dialing sequences used by the public network to deliver special services and features. Some public network features provide the caller with dial tone after they have entered the special code, usually **#** or *****, so users may have an opportunity to bypass restrictions. To prevent this from happening, you should create filters that block these special codes.

You create a filter by defining the dialing sequences that are denied.

There will also be variations of each sequence that you will want users to be able to dial. Sequences that can be dialed are called overrides.

Once you create the filters, you can assign the restrictions to a telephone (**Terminals&Sets**), to a line (**Lines**), to a particular line on a telephone (**Terminals&Sets**), and to remote callers (**Remote access**).

1. Press and enter the number of the restriction filter you want to program, or press to move through all the available filters.
2. Press to see the first restriction in the filter. The first four digits of the number that will be denied are included in the display. The full number can be seen by pressing again.
3. Use **ADD**, the dialpad, and **OK** to program a restriction for each filter.
4. Press when the full restricted number is on the display (it shows **Deny:** and the number) to see any overrides to the restriction.
5. Use **ADD**, the dialpad, and **OK** to program overrides for each restriction filter.
6. Press **ANY** to enter a wild card character that represents any digit in a sequence of numbers when denying numbers or creating overrides.
7. You can press **REMOVE** to delete a restriction. The overrides will be deleted as well and the restrictions will renumber to fill the gap.

Default filters

Filter 00 permits unrestricted dialing and cannot be changed.

Filter 01 is pre-programmed with five restrictions and some associated overrides.

In Filter 01, restriction 02 and override 005 allow long distance directory assistance calls. Filter 01 reflects the fact that area codes can now have any digit as a second digit. This is designed to be used with the North American dialing plan.

The dialing string 911, the number for emergency assistance in North America, is included as both a restriction and an override in filter 01. This arrangement prevents anyone from blocking calls for emergency assistance on lines or sets using the default filter.

The following table lists the initial defaults for restriction filters.

Restriction filter defaults

Filter	Restrictions (denied)	Overrides
00	Unrestricted dialing	
01	01: 0	
	02: 1	001: 1800 002: 1877 003: 1888
	03: 911	001: 911
	04: 411	
	05: 976	
	06: 1976	
	07: 1•••976	

Filter	Restrictions (denied)	Overrides
	08: 1900	
	09: 1***900	
	10: 5551212	
02 - 99	No restrictions or exceptions programmed	

Note: Default filters are only loaded at a cold start.

Filters 02, 03, and 04, although not preset with restrictions and overrides, are used as default filters in these programming headings:

Filter	Heading	Sub-heading
02	Terminals&Sets	Set restrns:
03	Lines	Line restrn:
04	Lines	Remote restrn:



Tips - *Filter 00 cannot be changed.*

Norstar can have up to 100 restriction filters (00 to 99).

Each programmable filter can have up to 48 restrictions. There is no limit on the number of overrides that can be allocated to a restriction.

There is a maximum of 400 restrictions and overrides allocated to the 100 programmable filters.

The maximum length of a restriction is 15 digits. The maximum length of an override is 16 digits.

A single dot (•) in a dialing sequence is a wild card (stands for any digit). It is inserted by pressing ANY.



You can use * and # in a sequence of numbers in either a restriction or an override. These characters are often used as part of feature codes for other systems or for features provided by the central office (the public network).

When restricting the dialing of a central office feature code, remember to create separate restrictions for the codes used for DTMF and pulse lines. Examples of dialing strings that may be restricted for this reason are *67 and 1167. Do not string together a central office feature code and a dialing sequence that you want to restrict. Create a separate restriction for each.

You can use COPY and the dialpad to copy restrictions and overrides from one filter to another.

Any restriction or override can be used in any number of filters. Each time it is used, it counts as one entry. For example, if restriction 411 exists in filters 01, 02 and 03, it uses up three entries of the 400 entries available.

Removing a restriction from a filter has no effect on the contents of other filters even if the restriction was copied to them.

You cannot delete a filter. Removing the restrictions programmed on a filter makes it an unrestricted filter but the filter itself is not removed.



Removing a restriction changes the identifying number of the restriction.

Removing a restriction also removes the overrides associated with it, and changes the identifying number of the restriction. For example, if you remove restriction 01, restrictions 01 to 08 are renumbered as 01 to 07.

Set restrns

Set restrictions allows you to assign a restriction filter to a telephone to prevent certain numbers from being dialed from that telephone. You can also use set restrictions to prevent certain features from being used by a telephone.

Filters

You can assign a different restriction filter for normal service and for each of the six schedules. Refer to *Services* on page 353 for more information about the schedules.

Use , **CHANGE** and the dialpad to enter the number of the restriction filter to be assigned to the set for each schedule.

The following table displays the default set filters.

Default filters for sets

Schedule	Restriction filter
Normal	02
Sched 1 (Night)	11
Sched 2 (Evening)	12
Sched 3 (Lunch)	13
Sched 4	00
Sched 5	00
Sched 6	00

Based on the defaults, if you enter a set of restrictions for filter 11, they will be automatically applied when the Night schedule is in use.

Set lock

You can adjust the amount of personal programming and customizing that can be performed at a telephone.

Press CHANGE to select a set lock level: **None**, Partial, or Full.

Allow last no

A telephone can be prevented from using Last Number Redial (5).

Press CHANGE to select the setting: **Y** (Yes) or **N** (No).

Allow saved no

A telephone can be prevented from using Saved Number Redial (6 7).

Press CHANGE to select the setting: **Y** (Yes) or **N** (No).

Allow link

A telephone can be prevented from using Link (7 1), an option that allows a caller to connect to an outside PBX.

Press CHANGE to select the setting: **Y** (Yes) or **N** (No).

For more information about host system signaling, refer to the Modular ICS 6.0 System Coordinator Guide.

Line/set restrns

Line/set restrns allows you to assign a restriction filter to a specific line that can be used for outgoing calls at a specific telephone. This type of filter replaces any line or set restriction filters which might otherwise apply. It restricts the numbers you can dial on a line, but only from that telephone. The same line on another telephone can have different restrictions.

As with set restrictions, you can apply a different line/set restriction for normal service and for each of six schedules.

Use , **CHANGE** and the dialpad to enter the number of the filter to be assigned as the line/set restriction for each schedule. There are no default line/set restrictions.



Tips - *A maximum of 255 line/set restrictions may be applied to lines at telephones.*

If a line/set restriction is assigned to a line at a particular telephone, it overrides any line restrictions or set restrictions which might otherwise apply.

If no line/set restrictions have been defined, the numbers are checked against the set restrictions and the line restrictions, if either of these have been defined. The numbers may be rejected by either restriction.

Telco features

Telco features can program the way the Norstar works with features and services that are based in the public network or other outside source. Norstar is designed to work with two of these kinds of services: Call Display and an external voice message service.

When you are finished programming Telco features settings for one telephone, you can copy those settings to other telephones by using **COPY** at the **Telco features...** display. For more information about copying set programming, see *Copying telephone programming* on page 290.

Feature assignment (CLID alignment)

If you subscribe to Call Display (Caller ID) services, external calls are identified on the display of telephones which have been programmed to display CLID. You may also have a message indicator from an external voice mail service show on the display. **CLASS** assignment programming allows you to customize how this information is used.

Press and enter the number of the line you want to program with **CLASS** settings for the telephone.

Caller ID set

Caller ID set allows you to specify if a telephone displays the Call Display information when a call is ringing on an external line. After the call is answered, Call Display information is always shown at the telephone that answered the call.

The Caller ID set for target lines is the same set that has appearance on that target line. Press **CHANGE** to select the setting: **N** (No) or **Y** (Yes).



Tip - In order for a telephone to display the Call Display information for calls on an external line, it must also be programmed to appear and ring or ring for that line.

For systems that subscribe to Call Display services, Caller ID can be viewed on any telephone by entering the Call Information feature code . See the Telephone Feature Card or Modular ICS 6.0 System Coordinator Guide for more information.

Call information does not automatically appear when the telephone has an Answer DN, or belongs to a Ring group activated by Ringing Service. Call information is still available for these calls by pressing .

Extl VMsg set

If you subscribe to a voice message service, you can access that service through your Norstar system. The external voice message setting controls where the indicator shows up when there is a voice message waiting on a particular line. The line must be assigned to appear on that telephone.

Press **CHANGE** to select the setting: **N** (No) or **Y** (Yes).

To find out if your voice message service will work with Norstar, or if you have any problems with your service, contact your voice message service provider.

1stDisplay

Depending on the services you subscribe to, Call Display information may contain the number of the caller, the name of the line in your Norstar system that the call is on, or both. For each telephone, you can determine which information is displayed first.

Press **CHANGE** to select the setting: **Name**, **Numbr** or **Line**.



Tips - *The Call Information feature is used to display and toggle between the name and line number used for Call Display information. Refer to Modular ICS 6.0 System Coordinator Guide for more information.*

*You may see **Unknown number** on the display if the information is not available from your telephone company. You may see **Private number** on the display if the caller blocks that information.*

Called ID

Called ID allows you to see the extension number and name of the set being called on the display. The Called ID set for target lines is the same set that has appearance on that target line.

Press **CHANGE** to select the setting: **N** (No) or **Y** (Yes).

Log space

Log space determines the number of items that can be stored in the Call log for each telephone.

Use , **ADD** and **REMOVE** to redistribute the log space. There is no log space assigned by default.



Tips - *There must be space available in the log pool in order for you to add space to a Call log. The maximum number of spaces available is 600.*

*System-wide log space allocation is performed in Call log space under **System Framing**. If you want to allocate the same log space to all telephones, use the Call log space setting instead.*

Lines

This chapter describes the settings that allow you to determine how the lines coming in and going out of the system will be assigned.

Lines, whether physical or virtual, are the connecting threads that allow users access into and out of the Norstar system to the public network or to other private networks.

Lines can be pooled so a number of sets of have access to more available lines, or they can be assigned specifically to one set. There are also a number of ways that a set can be configured to access line pools and special lines like tie lines and private network lines.

Trunk/Line data

Trunk data allows you to program settings for lines that affect how Norstar communicates with other switches. These settings also allow you to determine how lines, including target lines, will be used in the Norstar system.

Some Trunk data settings may not appear on the display during programming, depending on the type of trunk. Those that appear for a given Trunk type are indicated in the following table.

Trunk/Line data settings that appear for a given trunk type

Setting	Loop start Analog	Loop start Digital	E&M Analog	DID Analog	DID Digital	Target lines	PRI lines	BRI -ST BRI-U2 BRI-U4	Groundstart (T1)	E&M Digital	Fixed
Trunk type	✓	✓	✓	✓	✓	✓	✓	✓	✓	✓	✓
Line type	✓	✓	✓	✓	✓	✓	✓	✓	✓	✓	-
Dial mode	✓	✓	✓	✓	✓	-	-	-	✓	✓	-
Rec'd #	-	-	-	-	-	✓	-	-	-	-	-
If busy	-	-	-	-	-	✓	-	-	-	-	-
PrimeSet	✓	✓	✓	✓	✓	✓	✓	✓	✓	✓	-
Auto privacy	✓	✓	✓	✓	✓	-	-	✓	✓	✓	-
Trunk mode	✓	✓	-	-	-	-	-	-	-	-	-
Ans mode	✓	✓	✓	✓	-	-	-	✓	✓	✓	-
Ans with DISA	✓	✓	✓	-	-	-	-	✓	✓	✓	-
Link at CO	✓	-	-	✓	-	-	-	-	-	-	-
Aux. ringer	✓	✓	✓	✓	✓	✓	-	✓	✓	✓	-
Full AutoHold	✓	✓	-	-	-	-	-	✓	-	-	-
LossPkg	✓	-	-	-	-	-	-	-	-	-	-
Signal	-	-	✓	✓	✓	-	-	-	-	✓	-
ANI Number	-	-	✓	✓	✓	-	-	-	-	✓	-
DNIS Number	-	-	✓	✓	✓	-	-	-	-	✓	-
Gain	-	-	✓	✓	-	-	-	-	-	-	-

Copying Trunk and Line data

At the **Trk/Line data** display **COPY** appears. This allows you to copy programming from one line to other lines.



Tips - *In copying data from a physical trunk to a target line, or the other way around, only the data in common is copied. For example, copying a target line to an E&M trunk copies only the Line data settings because there are no Trunk data settings for a target line.*

*If you try to copy line programming between lines on different types of Trunk Cartridges, the display shows **Incompatible Cd**, then returns to **Show line: _**. You cannot copy programming between lines on different types of Trunk Cartridges.*

The Received number of a target line is a unique number and cannot be copied.

Trunk type

Installer password required

The Line setting shows **Loop**, DID, PRI, BRI-ST, BRI-U4, BRI-U2, E&M, Ground or Fixed.



Tips - *Changing the settings for a trunk type on a system that is in use, may cause calls to be dropped.*



Tips - *You can only change this setting for lines connected to a DTI. For all other lines, such as analog lines and BRI lines, the trunk type is determined by the Trunk Cartridge type. The system simply displays the trunk type; you cannot change it. To change the Trunk Cartridge or BRI Card, see Hardware on page 455.*



Enable Trunk Cartridges

If you disable any Trunk Cartridges to perform programming, enable them now using **Module status** in Maintenance or your system will not function properly. See *Module status on page 495* for information on enabling Trunk Cartridges in Module status.

Line type

Installer password required

This setting specifies how the line is to be used in relation to other lines in the system.

Press **CHANGE** to select the setting: **Public**, Private to:, or Pool (A to O, representing 15 line pools) or PRI-A or PRI-B.

- A **Public** line can be accessed by more than one telephone.
- A **Private** line can be assigned only to one telephone and the prime telephone for that line. Use **CHANGE** and the dialpad to enter the internal number of the telephone.
- **Pool** assigns the line to one of the 15 line pools. If a line is assigned to a line pool, but is not assigned to any telephone, that line is available only for outgoing calls.



Tips - *Line pools must never contain a mixture of loop start lines and E&M lines. All E&M lines in a given line pool should go to the same location.*

Try to avoid putting unsupervised loopstart lines in a line pool. These lines can become hung, especially when a remote user uses the line pool to make an external call.

There are two more programming settings that must be assigned before a line pool can be used:

- You must assign line pool access to telephones in **Line access programming**.
- You must assign system-wide line pool access codes in **System Programming**.



Tips - A telephone can be administered to search automatically for an idle line from several lines appearing on the telephone. Assign a line pool as the prime line (in **Line access**) and all the lines in the line pool must appear on that telephone. When the user lifts the receiver or presses the button marked Handsfree/Mute, any one of the lines, if idle, can be selected by Automatic Outgoing Line selection.

Line connected to a DTI

Installer password required

The Line setting shows the trunk type for a line.

For lines connected to a DTI, press **CHANGE** to select one of these settings: **Loop**, E&M, DID, Ground, Fixed, PRI.

- Loop is used for loop start trunks
- E&M is used for the first two line numbers on E&M trunks



Tips - E&M Trunk Cartridges have two E&M lines and two DTMF receivers (instead of four lines as in a Loop Start Trunk Cartridge). For example, if an E&M Trunk Cartridge has the range of line numbers 049 to 052, numbers 049 and 050 are E&M lines, and numbers 051 and 052 are the DTMF receivers. The display for line 050 appears as **Line050:E&M** and for line 051 appears as **Line051:DTMF**.

- DID is used for direct inward dialing trunks
- ground is used for groundstart (T1) trunks

- PRI is used for ISDN-PRI, which includes the SL-1 MCDN protocol for networking.



Tips - *Changing the settings for a trunk type on a system that is in use, may cause calls to be dropped.*

When assigning lines to line pools, consider your network configuration. You may be able to create a unified dialing plan by assigning lines to the same location to the same line pool on each of your systems. For example, if system A and system B each have tie lines to system C, assign the tie lines to pool D on each of the systems.

If you plan to program the prime line as I/C (intercom) for some telephones, you may wish to assign loop start lines to the first line pool. Remember that when the system searches for an outgoing line, it begins at line pool A and chooses the first available line.

Assigning a single E&M trunk to a line pool allows features like Ring Again to help manage access to a shared resource.

You cannot assign target lines (157-284/348) to a line pool.

Dial mode

Installer password required

Dial mode allows you to specify whether dual tone multifrequency (DTMF) or pulse signalling is used on the trunk.

Press CHANGE to select the setting: Pulse or **Tone**.



Tips - *For DID and E&M lines connected to a DTI, the Tone setting does not appear if Signal is Immediate.*

Rec'd #

Installer password required

The Received number setting applies only to target lines. Target lines are: 157 to 284 for MICS 6.0, and 157 to 348 for MICS-XC 6.0. It allows you to specify the digits which make a specific target line ring. The default value is **None**.

Use **CHANGE**, and the dialpad to program the digit string for each target line.



Tips - *A Received number can be three to seven digits long. It is programmed in **System Programming**. The default length is three for all systems.*

A received number cannot be the same as, or be the start digits of a line pool access code, a destination code, the DISA DN or the Auto DN.

If you are configuring auto-answer BRI trunks to map to target lines, the received number should be the same as the Network DN supplied by your service provider. The call will be directed to the prime telephone for the incoming line if the Network DN is not used.

If busy

When a call is received on a target line that is already busy, you can choose if the caller gets a busy tone or if the call is forwarded to the prime set.

Busy tone only works for PRI and BRI trunks on target lines.

Programming is done in Line Data under Lines. Press **CHANGE** to select one of these settings: **To prime** or **BusyTone**.

Prime set

Installer password required

This feature allows you to assign a telephone to provide backup answering for calls on the line. Unanswered calls are redirected to the prime telephone.

Use **CHANGE** and the dialpad to enter the internal number of the prime telephone.

The default prime set for each line on a system with three-digit DNIs is 221.



Tips - *For auto-answer trunks, calls ring only at the prime telephone for a trunk, and only when overflow call routing is active.*

Each line can be assigned only one prime telephone.

Auto privacy

Installer password required

This feature controls whether one Norstar user can select a line in use at another telephone to join an existing call. The default setting is **Privacy** on, so that nobody with a Norstar telephone can press a line appearance on their telephone to join a call in progress at another telephone.

Press **CHANGE** to select either: **Y** (on) or **N** (off).



Tips - *Users can change a line privacy setting for an individual call using the Privacy feature ().*

Note: This feature does not work on target lines or PRI lines.

Trunk mode

Installer password required

Trunk mode allows you to specify either disconnect supervision or unsupervised. Disconnect supervision, also referred to as loop supervision, releases an external line when an open switch interval (OSI) is detected during a call on that line. This prevents the line from remaining unavailable for other Norstar users.

Press **CHANGE** to select the setting: **Unspr** or **Super**.

- **Unspr** (the default) turns disconnect supervision off for the line.
- **Super** assigns supervised mode, if supported by the line. otherwise, the line functions as unsupervised.



Tips - *The duration of an open switch interval (OSI) before Norstar disconnects a call is programmed by the Discon timer setting under **Hardware**.*



Tips - *Disconnect supervision is required for loop start trunks to operate in auto-answer mode or with DISA. It is also required to conference with two external callers. The line must be equipped with disconnect supervision from the central office for the Super option to work.*

Ans mode

Installer password required

The Answer mode setting appears on the display during programming for loop start and BRI lines with a Trunk mode setting of Super, for groundstart (T1) lines, and for E&M lines. Press **CHANGE** to select the setting: **Manual** or Auto.



Tips - *If loop start lines are set to Auto, you will require an E&M card for the DTMF receivers to function properly.*

Remember that disconnect supervision is required if loop start trunks need to operate in auto-answer mode.

You should change the Answer with DISA setting to N for E&M trunks in a private network operating in auto-answer mode. The default, Y (Yes), causes the system to expect a Class of Service password after it automatically answers a trunk.

Ans with DISA

Installer password required

When activated, the Answer with DISA setting specifies that a trunk is answered with stutter dial tone. This feature is only active if Ans Mode is set to **Auto**.

Press **CHANGE** to select the setting: **Y** (Yes) or **N** (No).



Tips - *For loop start and E&M lines this setting only appears if Answer mode is Auto.*

Set Ans with DISA to No for E&M lines on an enhanced switched network (ESN) to operate properly in auto-answer mode.



Tips - *When an incoming call comes in on an auto-answer loop guarded or Earth calling line that is not configured to answer with DISA, the caller hears system dial tone. They can then enter a DIA line public received number to dial direct to an extension, a line pool access code to break out, or a remote feature code from a DTMF telephone if a suitable remote access package has been assigned.*

To program DISA on PRI trunk, see *Programming Direct Inward System Access (DISA) on PRI trunks* on page 64.

Link at CO (loop trunks only)

Installer password required

Some exchanges respond to a Link signal (7 1) by providing an alternative line for making outgoing calls.

- When **Link at CO** is set to **Y** (Yes), the system applies the restrictions on outgoing calls to the digits dialed after the Link signal, and the call on the alternative line will be subject to all restrictions.
- Setting **Link at CO** to **N** (No) prevents a Link signal from resetting the Norstar restrictions in cases where the host exchange does not provide an alternative line.

Press **CHANGE** to select the setting: **Y** (Yes) or **N** (No).

For more information about host signalling options, refer to *Modular ICS 6.0 System Coordinator Guide*.

Aux. ringer

Installer password required

This setting allows you to turn the auxiliary ringer on or off. An auxiliary ringer can be programmed on a line or a set. When programmed on a set, the auxiliary ringer will ring every time a call is received. When programmed on a line, the auxiliary ringer will not ring when a transferred call is received.

Press **CHANGE** to select the setting: **Y** (Yes) or **N** (No).



Tips - *The auxiliary ringer is an optional device that should be connected by the installer.*

If you have an auxiliary ringer programmed to ring for calls on an external line, and you transfer a call on that line without announcing the transfer, the auxiliary ringer will ring for the call transfer.



Tips - *An auxiliary ringer can also be programmed in Services to ring for a line placed into a scheduled Ringing service. See the Modular ICS 6.0 System Coordinator Guide for more information.*

Full AutoHold

Installer password required

Full AutoHold on idle line is a variation of the Automatic Hold feature. If you select an idle line, but do not dial any digits, that line is automatically placed on hold if you select another line.

Press **CHANGE** to select the setting: **N** (No) or **Y** (Yes).

The line you first selected is held until you press the line button. The line is not available for use by anyone else .



Tips - *The Full AutoHold setting appears only during loop start trunk programming. Full AutoHold is always in place for E&M trunks; it has no meaning for incoming-only DID trunks.*

Only change the default setting if Full AutoHold is required for a specific application.

LossPkg

Installer password required

Loss Package allows you to select the appropriate loss/gain and impedance settings for each line. The setting is based on the distance between the ICS and the terminating switch, and the terminating switch type. When measuring the distance from ICS to CO and from ICS to PBX, use 600 ohms as the termination resistance setting.

A loss of 4 dB corresponds to a cable length of approximately 2700 m (9000 ft.).

Press **CHANGE** to select one of the following settings.

The following table describes the five types of loss packages.

Loss Pkg	Receive Loss	Transmit Loss	Impedance	Distance to switch/ cable loss/terminating switch
ShortCO	0 dB	3 dB	Short	Short/<2 dB/ICS to CO
MediumCO	0 dB	0 dB	TIA/EIA 464	Medium/>2 dB and <6 dB/ ICS to CO
LongCO	-3 dB	0 dB	TIA/EIA 464	Long/>6 dB/ICS to CO
ShortPBX	0 dB	0 dB	Short	Short/<2 dB/ICS to PBX
LongPBX	-3 dB	0 dB	TIA/EIA 464	Long/>2 dB/ICS to PBX



Tips - *This setting applies only to lines connected to an NT7B75GA-93 Loop Start Trunk Cartridge.*

When measuring the distance from ICS to CO and ICS to PBX, use 600 ohms as the termination resistance setting.

Signal

Installer password required

Select the signal type for the line.

Press **CHANGE** to select one of these settings: **WinkStart**, Immediate, DelayDial.



Tips - *The Signal setting appears on the display only for E&M or DID lines.*

Make sure that this matches the signal type programmed for the trunk at the other switch.

For E&M and DID lines connected to a DTI, the Immediate setting does not appear if dial mode for the line is tone.

ANI Number

Installer password required

Select whether the telephone number of the caller will be collected for this line. The digits can then be displayed on Norstar telephones as part of Call Display services.

Press **CHANGE** to select either: **N** (No) or **Y** (Yes).



Tips - *The central office must deliver ANI/DNIS in DTMF mode. The delivery of ANI/DNIS depends on the network provider and the services they offer. This setting applies only to E&M and DID lines.*



For E&M or DID lines connected to a DTI, the setting only appears if Signal is WinkStart. For lines connected to an E&M or DID Trunk Cartridge, the setting only appears if Signal is WinkStart or Immediate.

If the conditions for signalling mode and start arrangement are not met, prompts are not presented to the user. No additional equipment is required.

DNIS Number

Installer password required

Select whether the digits dialed by an external caller on this line will be collected.

Press **CHANGE** to select either: **N** (No) or **Y** (Yes).



Tips - *This setting applies to E&M lines only.*

For E&M lines connected to a DTI, this setting only appears if Signal is WinkStart and Ans mode is Manual. For E&M lines connected to an E&M Trunk Cartridge, this setting only appears if Signal is WinkStart or Immediate and Ans mode is Manual.

These digits are required for some third-party software applications.

Gain

Installer password required

Select the appropriate gain level for the line.

Press **CHANGE** to select either: **Normal** or High.

The default value **Normal** induces zero loss. Use it when the E&M trunks are connected to facilities that present 0 dBm at the interface, for both the transmit and receive paths.

Normal gain level (0dBm)

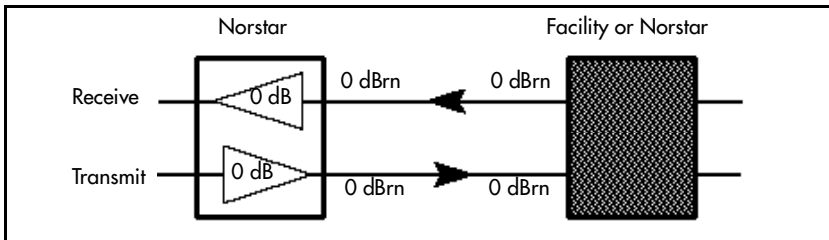

The value **High** induces 7 dB of loss in the receive path and 16 dB of loss in the transmit path. Use it when the E&M trunks are connected to facilities that present +7 dBm in the receive path, and -16 dBm in the transmit path, at the interface.

High gain levels

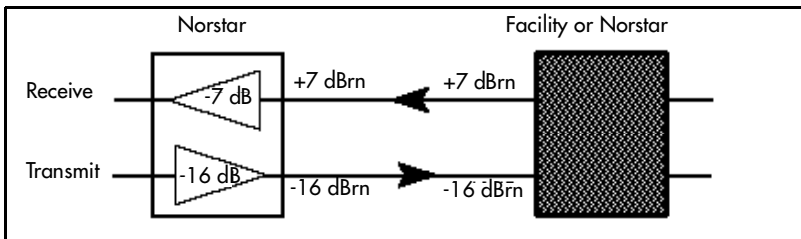

Tip - Control over the gain on transmission levels can only be set for lines on E&M Trunk Cartridges.

Programming distinctive ring patterns Installer password required

When lines are configured on your system, they can be assigned one of four distinctive ring patterns (DRP). The default for all telephones is 1; the default for lines is None, which is the lowest priority.

Call ringing: When multiple calls are presented to the telephone, the call with the highest priority DRP setting will be the call that rings at the telephone.

Call answering: When multiple calls are presented to a telephone, and the user picks up the handset, the call with the highest priority DRP setting is the call that is presented.

Note: External calls always have a higher priority than internal calls.

Note: If the ring type is changed on a telephone after the DRPs are set on the line, the line DRPs are overwritten by the telephone settings. If the line DRPs are set after telephone programming, then the telephone ring programming is overridden by the DRP. Refer to the *Modular ICS System Administrator Guide* for details about setting ring types on a telephone.

If Hunt group DRP has a higher priority than the line DRP, the system will use the Hunt Group DRP within the Hunt Group. (Refer to *Assigning a distinctive ring pattern to a Hunt Group* on page 392.)

1. Place the programming overlay over the appropriate keys on your programming telephone.
2. Press (CONFIG). The display shows **Password:**.
3. Press (CONFIG). The display shows **Terminals&Extns.**

4. Press until the display shows **Lines**.
5. Press . The display shows **Linexxx:Line XXX**.
6. Press **FIND** and enter the line to which you want to define a ring pattern.
7. Press until the display shows **TrunkType:PRI**.
8. Press until the display shows **Dstnct ring: NONE**.
9. Press **CHANGE** to toggle to the ring pattern number you want to assign to the line (**None, 2, 3, 4**).
10. Press to exit or to continue programming.

Name

The default name for a line is Line XXX, XXX being the three-digit line identifier. For example, Line 001.

This can be changed to any combination of letters and numbers to a maximum length of seven characters.

For more information, refer to *Modular ICS 6.0 System Coordinator Guide*.

Restrictions

Use Restrictions to prevent a user from using a line for making certain kinds of calls. For example, users should not be able to make long-distance calls on lines used exclusively for local calling.

Restrntn filters

Restriction filters are groups of dialing restrictions and dialing overrides for external numbers or feature codes. By packing a set of restrictions and overrides in one group, you can assign them to a line in one step, as a single package.

You can make changes to restriction filters under both **Terminals&Sets**, and **Lines**. Any changes will take affect for any telephone, line, or line on a telephone, regardless of where the programming was changed.

See the description and procedures in *Restrictions* on page 349.

Line restrtns

Specify the filter to be applied to this line to restrict the numbers that can be dialed on it. You can assign a different restriction filter for normal service and for each of the six schedules. See the section on Services for more information about the schedules.

Use , **CHANGE** and the dialpad to enter the number of the restriction filter to be assigned as the line restriction for each schedule.

The default restrictions are shown in the table below:

Default filters for lines

Schedule	Restriction filter
Normal	03
Sched 1 (Night)	21
Sched 2 (Evening)	22
Sched 3 (Lunch)	23

Schedule	Restriction filter
Sched 4	00
Sched 5	00
Sched 6	00



Tips - *When a remote user places an external call on a line, any filters used with the line still apply.*

Remote restrns

Specify the restriction filter to be applied to remote callers calling in to the Norstar system on this line. A restriction filter is a set or group of restrictions and overrides.

As with line restrictions, you can apply a different remote restriction for normal service and for each of six schedules.

Use **CHANGE** and the dialpad to program the remote restrictions for each schedule.

The default restrictions are shown in the following table.

Default filters for remote access

Schedule	Restriction filter
Normal	04
Sched 1 (Night)	31
Sched 2 (Evening)	32
Sched 3 (Lunch)	33
Sched 4	00
Sched 5	00
Sched 6	00



Tip - *The remote restriction restricts the numbers that can be dialed on an incoming auto-answer line. If a remote user then selects a line to place an external call, any filter used with the line still applies.*

Telco features

This item allows you to assign features that occur from a telco level.

VMsg center 1

If you subscribe to a voice message service, you can specify which voice message center is used for each external line that can receive message waiting indication.

1. For each line, press CHANGE to select a message center:
1, 2, 3, 4, 5, or N.

Note: If your system is part of a network that provides a central voice mail system on another site, you must use this field to specify that service.

Services

Using Services, you can control three types of service using the time of day and the day of week:

- alternate call ringing, see page 357
- alternate dialing restrictions, see page 360
- alternate call routing, see page 361

You can customize services in general under Common Settings. Refer to *Common settings* on page 354.

Within each type of service, you can customize six schedules.

For example, you may want to combine alternate call ringing with alternate dialing restrictions for lunchtime, evenings, and weekends (Schedules 1, 2, and 3). Then you may want to run alternate call routing using three separate schedules.



Tips - *Once you have programmed the different services and schedules, you can turn each of the services on separately. For example, the Night schedule might control both Ringing service and Restriction service. But you can turn on just the Ringing service part of the Night schedule if you wish.*

You can activate the services from the designated control telephone for each Norstar telephone and line in your system. You can have one control telephone for the whole system, or different control telephones for different Norstar telephones and lines.

If you want to have several services active at the same time, simply program them on for the same schedule.

Common settings

Services share the settings for control telephones, schedule names, and schedule times.

Control sets

A control telephone turns Services on and off for the lines and/or telephones assigned to it. You can assign several control telephones for your system.

A control telephone for lines controls Ringing service, Restriction service and Routing service for its assigned lines.

A control telephone for telephones controls Restriction service and Routing service for its assigned telephones. Assign a control telephone for each external line and telephone.

Use , , **CHANGE** and the dialpad to program the internal number of the control telephone for each line and each telephone.

Control set configurations for both lines and telephones can be copied from one set/line to another set/line or to a range of sets/lines, or to all sets/lines, using the **COPY** softkey.



Tips - *External lines and telephones must be programmed with a control telephone to use the three kinds of Services. You can assign a control telephone to more than one external line or telephone, but a line or telephone cannot be assigned to more than one control telephone.*

One recommendation is to have one control telephone for all lines and a different control telephone for all telephones.



Tips - A service can be turned on manually or automatically for all external lines and telephones controlled by a given control telephone, but you cannot combine schedules. In other words, a service can only be active as normal service or one of the six schedules at any one time. You can have several schedules active, as long as they are using different services.

The default control telephone for all lines and telephones is 221 (for systems with three-digit DNs).

Schedule names

The schedule name is shown on the display of the control telephone when the schedule is turned on. It identifies the active schedule.

Use , , and **CHANGE** and the dialpad to program the name.



Tips - The default names of the six possible schedules are only suggestions and may be changed to any other name. A schedule name can be one to seven characters long. It is recommended that you reserve certain schedules (4, 5, and 6) exclusively for alternate call routing (Routing service).

Schedule times

Schedule start and stop times are set at times you are most likely to want each service to be active.

Use , , and **CHANGE** and the dialpad to program the start and stop times for each schedule, on each day.

Default schedule times

Schedule	Start time	Stop time
Schedule 1: Night	23:00	07:00
Schedule 2: Evening	17:00	23:00
Schedule 3: Lunch	12:00	13:00
Schedule 4: Sched 4	00:00	00:00
Schedule 5: Sched 5	00:00	00:00
Schedule 6: Sched 6	00:00	00:00



Tips - *It is only necessary to program start and stop times for schedules that are activated automatically. See the instructions with Ringing service for information on activating schedules.*

*The time may be entered in either 12 or 24-hour format. If the display is in English, and the hour entered is less than 13, the display prompts you to specify **AM** or **PM**.*

If you assign identical start and stop times for a schedule, for example, 04:00 start and 04:00 stop, the schedule is in effect all day. The only exception to this is a start and stop time of 00:00. In that case the schedule is off for the day.

You may assign overlapping times. For example, if schedule 1 is assigned from 9:00 am to 4:00 pm, and schedule 2 is assigned from 1:00 pm to 5:00 pm, then the start time of the second schedule is treated as a stop time for the first schedule.



Tips - *This is also true if two schedules have the same start time but different stop times. In that case, the stop time of the shorter schedule is treated as the start time of the longer schedule.*

If one schedule starts and stops within the times of another schedule, the first service temporarily ends when the second service starts. The first service then resumes when the second service has ended.

Some schedules start and stop at the same times each day. Use COPY to copy the start and stop times from one day to the next.



Start and stop times cannot span days.

When you program a schedule to start in the evening and stop in the morning, it does not carry over into the next day. For example, if you program Night service for Friday (22:00 to 06:00), the system turns on Night service from midnight to 6 am on Friday, and then again from 10 pm to midnight on Friday.

Ringling service

At certain times or in certain situations, you may want additional telephones to begin ringing for incoming lines. The most common use of this feature is when a security desk telephone begins to ring for incoming lines after 5:00 p.m., a practice often called *night service*.

These features are programmed under **Ringling service**.

Ringling groups

Ringling groups allows you to define groups of extended ringing sets. A group can be assigned to any line for any of the schedules. You can create up to 100 ringling groups composed of up to 30 sets for each ringling group.

To define a ringling group use and enter the number of the group you want to program (01-100).

Once you define a ringling group, the display will prompt you to enter the number of the set you want to assign to this ringling group. You can use **SCAN** to display the sets that are assigned to the ringling group.



Tips - *You can assign any set on the Norstar system to a ringing group. The assigned control set for each schedule is added to each ringing group.*

A set can belong to more than one ringing group.

Sched:Night

Indicate how Ringing service should be activated for each of the schedules.

Service

Use and **CHANGE** to change the setting for each schedule to : **Off**, **Auto**, or **Manual**.

Off — prevents the service from being activated.

Auto — allows you to program a stop and start time for a service. You will be prompted to enter start and stop times. You can still start and stop the service by entering the appropriate Services feature code at a control telephone.

Manual — allows you to turn the service on and off at any time from a control telephone using the Ringing service feature code.

Trunk answer

Trunk answer allows you to answer, from any telephone, an external call that is ringing at another telephone in your office. This is useful if the other telephones have not been assigned the same lines as the telephone you are using to answer the call.

Press **CHANGE** to select the setting: **Y** (Yes) or **N** (No).



Tip - You can change the Trunk Answer setting only if Ringing service is set to Manual or Automatic.

ExtraDial telephone

ExtraDial telephone allows you to assign an additional direct-dial telephone in the Norstar system for each schedule you use.

Use **CHANGE** and the dialpad to enter the internal number of the extra-dial telephone.



Tip - The extra-dial telephone is activated during a schedule by entering the Ringing service feature code from a direct-dial telephone. This does not activate the Ringing service unless the direct-dial telephone is also a control telephone.

Line settings

The ring groups and auxiliary ringer use for Ringing service is programmed for each line individually.

Ringling group

You can assign a predefined ringling group to a line for each schedule. See *Ringling groups* on page 357 to create groups of extra ringling telephones.

Use the dialpad to enter the line number to see which ringling group is assigned to the line.

To choose a different ringing group assignment, press **CHANGE** and enter the new ringing group number (01-100)



Tip - Only one ringing group can be assigned to a line for each schedule. To combine groups of ringing sets, you must create a new ringing group which contains all the sets you want to ring and assign it to the line.

Aux. ringer

Indicate whether the auxiliary ringer, if installed, also rings when Ringing service is on.

Press **CHANGE** to select either: **Y** (Yes) or **N** (No).



Tips - The default ringing telephone is 221 (for systems with a DN length of 3). This means that all lines ring at telephone 221 when Ringing service is on.

You can use **COPY** and the dialpad to copy Ringing set and Auxiliary ringer programming from one line to another.

If you have an auxiliary ringer programmed to ring for calls on an external line, and you transfer a call on that line without announcing the transfer, the auxiliary ringer will ring for the call transfer.

Restrn service

Indicate how the alternate dialing restrictions should be activated for each of the schedules.

Use and **CHANGE** to change the setting for each schedule: **Off**, Automatic, or Manual.

For information on using schedules, refer to the *Modular ICS 6.0 System Coordinator Guide*.



Tips - *A schedule must be active for overflow routing to be in effect. Overflow routing is not available in normal mode.*

You must create an overflow route to be used with each destination code. In this way, every route used with a scheduled mode that has overflow service must have an alternate route in normal service.

See *Ringin* service on page 357 for descriptions of the three activation settings.

See **Restrictions** under both **Terminals&Sets** and **Lines** to assign dialing restrictions for telephones, lines and remote users to the schedules.

Routing service

The programming for routing decides what path an outgoing call takes using the digits that are dialed. It is sometimes called Automatic Route Selection (ARS).

When you select an internal line and dial, the numbers you enter are checked against the routing tables. If the number you dialed starts with a destination code, the system uses the line pool and dials out digits specified by the route assigned to that destination code, and then dials the rest of the number that you dialed.



Plan your routing service before doing any programming.

Routing affects every call placed in the system and must be carefully planned to avoid conflicts and gaps in the programming. Use the tables in the *Programming Record* to design routes and destination codes, then check for potential problems before you start programming.

Routing service replaces a number of tasks that otherwise have to be done manually, including:

- entering a line pool code
- dialing an access code for a long distance carrier
- deciding which line pool to use according to the time and day

The installer can set up routing to take advantage of any leased or discounted routes using information supplied by the customer. The system itself cannot tell which lines are cheaper to use.

For Call by Call service selection (PRI only), the installer defines destination codes for various call types over PRI lines (e.g. Foreign Exchange, Tie Trunk, and OUTWATS). This information is then recorded in the routing and dialing plan section of the Programming Record for the PRI Pool-A (and PRI Pool-B if there are two PRI cards).

The user simply dials a number via the intercom button without having to enter any special information. For more information see, *Programming Call by Call service selection* on page 436.

How to use routing to create a uniform dialing plan (UDP) or coordinated dialing plan (CDP) is explained in *Dialing plans* on page 94.

Routes and destination codes

Installer password required

Programming for a route makes use of:

- destination codes (maximum of 500 available with a maximum of seven digits per code)
- a three-digit route number (000-999)
- a line pool
- DialOut digits (up to 24 digits)
- a schedule (programmed in Services)



Routing table modifications

Changes to the routing tables can only be made during low-activity periods or on an idle system. Plan to program the routing tables when user activity is at a minimum.

Alternatively, Norstar Remote Utilities (NRU) can be used to back up, modify and restore these tables.



Tips - *To dial a telephone number which does not match any of the programmed destination codes, the user chooses a line and dials the number. For long distance dialing, area codes in the North American numbering plan can be programmed as destination codes.*

Routes

Installer password required

Press and enter a three-digit route number (000-999).

DialOut

DialOut is the number you want the route to use.

Press and enter the DialOut digits (up to 24), or press **CLR** to choose **No number**.

You can press to insert a 1.5-second pause in the dialing string, if necessary.

Route 000 has no DialOut by default and cannot be changed.

Link – if your Norstar system is connected to a private branch exchange (PBX), you can use a Link signal to access special features.

Pause – Enters a 1.5 second delay in a dialing sequence on an external line.

Programmed Release – performs same function as in a programmed dialing sequence. When the system encounters Programmed Release in a dialing sequence, it stops dialing and hangs up the call.

Run/Stop – inserts a break point into a sequence of dialed numbers or characters used for automatic dialing.

Wait for Dial Tone – causes a sequence of numbers to pause until dial tone is present on the line before continuing to dial.

See the *Modular ICS 6.0 System Coordinator Guide* for more information.

Use Pool

Press and **CHANGE** to select a line pool to be used with the route: **Pool A**, Pool B...Pool O or PRI-A, PRI-B, PRI-C, or PRI-D.

Route 000 uses Pool A by default and cannot be changed.

Routing table

Call by Call Service information for outgoing calls is recorded in the Routing Service section of the Programing Record.

The following is an example of a Routing Table containing CbC programming.

Route # (000-999)	Dial Out (24 digits)	Use Pool	Service Type	Service Identifier
003		PRI-A	Public	
004		PRI-A	FX	xxxxx
005		PRI-A	Tie	xxxxx
006		PRI-B	OUTWATS	xxx
007		PRI-B	Private	
008		PRI-B	Switched Digital	

Note: The public DN lengths are used for all PRI calls except those whose routes use service type Private or service type Tie with DN Type specified as Private.

The service identifier (SID) depends on the selected service type. For example, with NI-2 protocol.

Service Type	Service Identifier description
Public	None
FX	Facility Number 1-5 digits
Tie	Facility Number 1-5 digits
OUTWATS *	Optional Band Number 1-3 digits
Private	None
Switched Digital	None

* For NI-2, do not program the Carrier Access Code for banded OUTWAT calls. This call may be rejected.

When a PRI protocol is selected or changed, the Service Type and Service ID fields are automatically cleared for each entry in the routing table for that PRI.

Programming the PRI routing table

The dialing plan must be thoroughly planned out in advance before programming the information into the Norstar system.

Programming the routing table takes place in **Services** under **Routing Service/Routes**

1. Press . The display shows **Rte000**.
2. Press . The display shows **Rte001**.
3. Press . The display shows **Dial-Out:No numbr**. Press **CHANGE** to enter a number (up to 24 digits).
4. Press . The display shows **Use: Pool A**.
The PRI pool(s) displayed depend on how the PRI lines are put into pools in the Trunk/Line data section of programming. It is possible to have only one PRI pool even if there are two or three PRI cards in the system.
5. Press . The display shows **SrvcType:Public**. Press **CHANGE** if you want to select a different Service Type.
Note: This parameter displays for specific protocols, such as N12, DMS100, DMS250.
6. Press . The display shows **Service ID:None**. Press **CHANGE** to enter the Service ID number. This is shown only if the service requires an ID.

Note: This parameter displays for specific protocols, such as N12, DMS100, DMS250.

7. Press . The display shows **DN type:Public**. Press **CHANGE** to enter Public or Private.

Note: This variable displays only for service type Tie.

Dest codes

Installer password required

The first digit of the destination code cannot be the same as:

- Call Park Prefix (*Park prefix* on page 418)
- External Access code (*External code* on page 419)
- Direct Dial numbers (*Direct-dial #* on page 419)
- Line Pool code (*Line pool codes* on page 417)

The entire destination code cannot conflict with:

- internal set numbers (*Terminals&Sets* on page 308)
- DISA DN's (*DISA DN* on page 421)
- Auto DN's (*Auto DN* on page 420)

For instance, if your park prefix is 1, and you want to start your destination codes with 1, you must change the park prefix.

If your line pool code for the local PBX is 9, and you want to start your destination codes with 9 to allow routing to the local PBX, you must create a destination code that includes the line pool for the PBX and delete the line pool code for 9.

The following are the *default* numbers automatically assigned in MICS-XC 6.0:

System type	Expansion used	Initial digits pre-assigned
mini	no expansion	0, 1, 2, 6 & 9
midi	one 2-port cartridge	0, 1, 2, 3, 6 & 9
maxi	one 6-port cartridge	0, 1, 2, 3, 4, 6 & 9

System type	Expansion used	Initial digits pre-assigned
mega	two 6-port cartridges or two combo cartridges	0, 1, 2, 3, 4, 5, 6 & 9

The following are the *default* numbers automatically assigned in a MICS 6.0 system:

System type	Expansion used	Initial digits pre-assigned
mini	no expansion	0, 1, 2, 3, 4, 5, 6, 7, 8 & 9
midi	one 2-port cartridge	0, 1, 2, 3 & 9
maxi	one 6-port cartridge	0, 1, 2, 3, 4 & 9

To make the digits available for use with destination codes, you must change the DN length of B1 and B2 DNs, depending on your system size. This can be done either at system startup or in **SYSTEM PROGRAMMING**. The examples shown above use a three-digit DN length, unless stated otherwise.

Wild card character

When programming destination codes, you can use wild cards as the last number in a destination code string. By using wild cards, you can reduce the number of destination codes programmed in the system, maximizing the distribution of destination codes in the system.

The wild card character is added to the destination code by pressing the **ANY** key as the last digit of the code. This character represents any digit from 0 to 9, except for digits already programmed or used by other numbering plans. Should there be a conflict with other digits already programmed or used with by numbering plans, the digit will not be displayed.

The wild card character can only be used to group destination codes that use the same Route and Absorb Length.

Given the routes shown in the table below, the next two tables show you how to set up destination codes with or without wild card characters.

Route	DialOut	Line Pool
555	0162 237 625	Line Pool C
565	0173 133 2211	Line Pool A

Destination codes without using a wild card character

Destination codes	Route	Absorb Length	DialOut
0621	555	3	0162 237 6251
0622	555	3	0162 237 6252
0623	555	3	0162 237 6253
0624	555	3	0162 237 6254
0625	555	3	0162 237 6255
0626	555	3	0162 237 6256
0627	565	All	0173 133 2211
0628	555	3	0162 237 6258
0629	555	3	0162 237 6259

Destination codes using a wild card character

Destination codes	Route	Absorb Length	DialOut
062 •	555	3	0162 237 625X where X is the final dialout digit, from 1 to 9, but not 7
0627	565	All	0173 133 2211

Normal rte

Select which route a call using the destination code takes during normal service and for each of the schedules. The automatic schedule times are programmed under **Services**. The default Normal route is **000**, which has no DialOut digits and uses Pool A.

Digit Absorption

Select the portion of the destination code that is always absorbed by the system and not used in the dialing sequence.

Press **CHANGE** to select the number of digits to be deleted: 0, 1, 2, 3, 4, 5, 6, or **All**.



Tips - *The digit absorption setting (**Digit absorb**) only applies to a maximum of two schedules.*

Setting digit absorption to 0 (zero) minimizes the effort involved in preparing destination codes. With a 0 setting, the actual digits dialed by a caller are preserved in the dialout sequence. Programming a DialOut sequence as part of the route may or may not be necessary depending on the required dialout.

Setting up a route for local calling

An office may have different suppliers for local and long distance telephone service. By programming a destination code, any call that begins with 9, the most common dialout digit, will automatically use lines dedicated to local service.

The first step is to build a route (under `Services/Routing Service/Routing`).

1. At `Show route:` enter 001 (or any other available route number)
2. Press `SCAN` to view defined routes and `CLEAR` to erase a defined route.
3. Choose the line pool that contains the lines for local calling.
4. Enter the DialOut digits (if any) which are needed to direct the call once it is connected to an external line.

Note: For local calls only, there are no DialOut numbers.

Compare this with *Setting up a route for long distance calling* on page 373.

5. Now you need to set up a destination code that will use this route during the various schedules. Since users will dial 9 to make an external call, 9 should be the destination code. (`Services/Routing Service/Dst Codes`)
6. At `Show DstCode:` press `ADD` and enter 9.



Tips - *If entering a code other than 9, a valid destination code must be used. See Dest codes on page 367.*

To view existing destination codes press before entering a new code.



Tip - The destination code can use a different route depending on which schedule is being used. Refer to *Services in the Modular ICS 6.0 System Coordinator Guide* for information about using schedules.

In the current example, Route 001 is used when someone dials 9 during normal mode. This is the mode used when the other Schedules are turned off.

7. Press .

The route for the first schedule appears after **Normal:**.

8. Press **CHANGE** and enter the defined route number 001.

The following illustrations show the tables used for planning and recording routing service found in the *Programming Record*. They are filled out to match the examples of routes for local and long distance calling.

Recording the routes

Page 24		
Routing Service (Services: Routing Service)		
Route # (000-999)	DialOut (if required) (max. 24 digits or characters)	Use Pool
001	none	A B C D E F G H I J K L M N O
002	none	A B C D E F G H I J K L M N O
		A B C D E F G H I J K L M N O
		A B C D E F G H I J K L M N O
		A B C D E F G H I J K L M N O

Recording how the routes will be used

Destination codes (Services; Routing service; Destination codes)								
Service Schedule name (max. 7 char)	Normal Rte		Night Rte		Evening Rte		Lunch Rte	
	Use route (000-999)	Absorb Length	Use route (000-999)	Absorb Length	Use route (000-999)	Absorb Length	Use route (000-999)	Absorb Length
9	000001	All		All		All		All
1	000002	All-0		All		All		All
	000	All		All		All		All
	000	All		All		All		All

Setting up a route for long distance calling

An office may have leased lines or E&M trunks which make it cheaper to call long distance.

The routing should take place automatically when the number of the outgoing call begins with 1.

The first step is to build a route (under **Services/Routing Service/Routing**).

1. At **Route#:**, enter 002 (or any other available route number)
2. Choose the line pool where the discounted lines for calling long distance have been placed. Example: Line pool B.
3. Then you need to assign the route to the destination code and to the destination code schedules. (under **Services/Routing Service/Dest Codes**)
4. At **DestCode#:** enter a valid destination code. Example: 1
Refer to *Dest codes* on page 367.



Tip - To view existing destination codes press before entering a new code.



Tip - The destination code can use a different route depending on which schedule is being used. Refer to *Services in the Modular ICS 6.0 System Coordinator Guide* for information about using schedules. In the above example, the system uses Route 002, which uses Line pool B, to take advantage of the lower cost when the system is in normal mode.

5. Press .

The route for the first schedule appears: **Normal:**

6. Press **CHANGE** and enter the defined route number 002.
7. Press .

The AbsorbLength prompt appears. The default is All.

8. Press **CHANGE** to choose the number of digits that need to be absorbed before dialout. In this case, it would be 0, as 1 needs to be dialed out before the rest of the digits.



Tips - The digit absorption setting (**AbsorbLength**) only applies to a maximum of two schedules.

Setting **AbsorbLength** to 0 (zero) minimizes the effort involved in preparing destination codes. With a 0 setting, the actual digits dialed by a caller are preserved in the dialout sequence. Programming a DialOut sequence as part of the route is not necessary.



Tips - *If rates change depending on the time of the day or week, a different route can be used for the same destination code 1 when a particular schedule is in use. See Programming for least cost routing on page 377.*

Adding a long distance carrier access code

In many cases, long distance service uses the same lines as local service but the call is switched to a specific carrier using an access number. This number is sometimes called an equal access code. Programming for routing can include this access number so users only need to dial the set number, as described below:

1. Create a route that uses a line pool containing local lines only.
2. Program the route to use a line pool containing the lines used to access the long distance carriers.
 - a. Enter the DialOut digits, which are the same as the carrier code digits. For example, if the access code was 10222, the DialOut digits would be 10222.
Carrier codes are defined in *Carrier Codes* on page 422.
 - b. Create a destination code 91.
9 (for outside access) and 1 (for long distance). Refer to *Dest codes* on page 367 to determine a valid code.
 - c. Set `AbsorbLength` to 1.
The 9 is only used internally and should be dropped.
The 1 is needed to direct the call to the public carrier network.



Tips - The destination codes 9 and 91 used in the examples cannot be used together. If the destination code 91 is needed to direct long distance calls, you must create a separate set of codes that use local calling routes. These codes would be, for example, 90, 92, 93, 94, 95, 96, 97, 98 and 99. See Wild card character on page 368 for information on programming destination codes.

Using destination codes to make a call

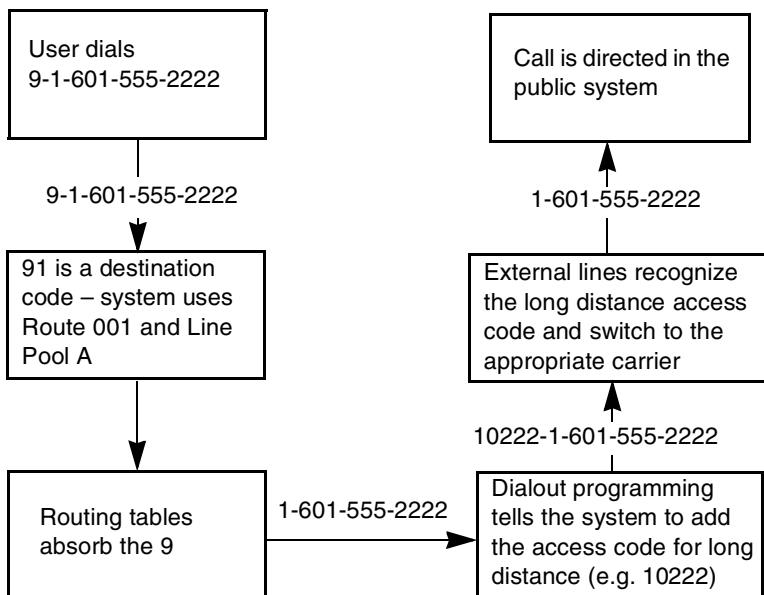

Programming for least cost routing

It may be cheaper to use another long distance carrier at another time of day.

Continuing with the example used in the previous flowchart, the lines that supply local service in normal mode will also be used for long distance service after 6 p.m. because that is when rates become competitive. For the system to do this automatically, another route has to be built.

1. At **Route:** choose Route 007 (or any available route).
2. Press .
3. At **DialOut**, press CLR to choose **No numbr.**
4. Press .
5. Choose Line pool A, or the pool with the local service carrier lines.

In this case, the change in route uses the start and stop times for Night Sched.

6. Return to the Routes heading and press to find the **Dest. Code** heading.
7. Press and then .
8. At **DestCode:**, press ADD, then enter 91.
9. Press and then .
10. Under **Night rte:** enter Route 007.
11. Press .
12. Set **AbsorbLength** to 1.

The 9 will be absorbed before the number is dialed out to the network. This means, that when the Night schedule is

chosen, either automatically, by time, or manually from a control telephone, the calls dialed with 91 will dial out to the long distance network without requiring a special access code.

Sched:Night

Indicate how the alternate routing should be activated for each of the schedules.

Service

Use , **CHANGE**, and to change the setting for each schedule to one of these settings: **Off**, Automatic, or Manual.

Off — prevents the routing service from being activated. In this case, the Normal schedule is used.

Auto — allows you to program a stop and start time for a service. You will be prompted to enter start and stop times. You can still start and stop the service by entering the appropriate Services feature code at a control telephone.

Manual — allows you to turn the service on and off at any time from a control telephone using the Ringing service feature code.

Refer to the Modular ICS 6.0 Coordinator Guide for a description of the feature codes used to work with Services.

Overflow routing

If all the lines used by a route are busy when a call is made, the mode may be programmed to overflow to the route used for normal mode. If this happens, the set will sound a warning tone and display the message **Expensive route**. The caller can then release the call to avoid using the normal route, or continue with the call.

Overflow routing is turned on or off for each schedule when you program the destination codes schedule.

Press CHANGE to select the setting: **Y** (Yes) or **N** (No).

Refer to the *Overflow call routing* section of the *Modular ICS 6.0 Coordinator Guide* for details about how to set up overflow routing.



Tips - *A schedule must be active for overflow routing to be in effect. Overflow routing is not available in normal mode.*

You must create an overflow route to be used with each destination code. In this way, every route used with a scheduled mode that has overflow service must have an alternate route in normal service.

Using dialing restrictions with routing

Routing service can be further customized by adding dialing filters to lines in line pools. Filters restrict the use of the line to specific area codes. See *Restriction filters* on page 86 and the *Programming* chapter of the *Modular ICS 6.0 System Coordinator Guide* for more information.



Tips - *Host system signaling codes can be part of the DialOut. See the Modular ICS 6.0 System Coordinator Guide for details on host system signaling codes.*



Tips - *You can also use routing as an alternate method for a direct-dial number. For example, create a destination code 0 and program the number of the internal or external destination as the DialOut. Digit absorption should be set to 1.*

Because overflow routing directs calls using alternate line pools, a call may be affected by different line filters when it is handled by overflow routing.

Sys speed dial

System speed dial allows you to configure speed dial codes (001 - 255) that can be used by any telephone on the system to dial pre-programmed numbers.

If you specify a name with the speed dial entry, an incoming call on a CLID line with a dialed number that matches the speed dial entry will display the name as part of the CLID display on the receiving telephone or when  8 1 1 is invoked to display call information. This method of using the system speed dial entries for CLID display is called Alpha tagging.

Note: Alpha tagging is only invoked when the CO line service does not supply a name for the incoming call. It will only occur on telephones that have Caller ID set turned on (*Telco features* on page 330).

The CLID Match setting (*Clid match* on page 409) determines how many digits of the received number need to match the system speed dial number to be accepted as a CLID match to allow the name display to occur.

For more information about using and programming System speed dial, refer to the *Modular ICS 6.0 System Coordinator Guide*.

For information about configuring the system so that the name displays first, refer to *1stDisplay* on page 331.

Passwords

COS pswds

Class of Service (COS) passwords permit controlled access to system resources by both internal and remote users.

When you enter a COS password at a telephone, the restriction filters associated with your password apply instead of the normal restriction filters. Similarly, when a remote user enters a COS password on an incoming auto-answer line, the restriction filters and remote package associated with their COS password apply instead of the normal restriction filters and remote package.

COS passwords allows you to define individual passwords and determine the restriction filters and remote package associated with each.



Tips - *The Class of Service passwords for a system should be determined randomly and should be changed on a regular basis.*

Users should memorize their COS passwords. COS passwords should be deleted when an employee leaves the company.



Tips - *Typically, each user has a separate password. Alternately, several users can share a password or one user can have several passwords.*

A system can have a maximum of 100 six-digit COS passwords (00 to 99).

*You can use **COPY** and the dialpad to copy the restriction filters and remote package from one COS password to another. COS passwords must be unique.*

Pswd

Pswd defines the six-digit Class of Service password.

There is no default password.

Use , CHANGE and the dialpad to program the six-digit password.

Use BACKSP to edit numbers you have entered.

User flt

User filter allows you to assign a restriction filter to a COS password. The user filter associated with the COS password replaces any normally applicable set restriction, line/set restriction, or remote restriction.

Use CHANGE and the dialpad to program the two-digit user filter.

The default setting (**None**), means that any normally-applicable filters still apply (set restriction, line/set restriction, or remote restriction).

Line flt

Line filter allows you to assign a specific line restriction to a COS password. The line filter associated with the COS password replaces any normally-applicable line restriction.

Use CHANGE and the dialpad to program the two-digit line filter.

The default setting (**None**), means that any normally-applicable line filter still applies.

Remote pkg

Remote pkg allows you to assign a specific remote access package to a COS password.

The remote access package associated with the COS password replaces any normally applicable remote access package.

Use **CHANGE** and the dialpad to program the two-digit remote package.

The default setting (**None**), means that any normally_applicable remote access package still applies.

Call log pswds

This setting allows you to override any Call log password programmed with the Call log feature, and resets it to **None**. This feature is used when someone forgets a password.

1. Press and enter the DN of the telephone.
2. Press and then **CLR** to clear the programmed password.



Tips - You program a Call log password using the Call log Password feature. Refer to the Telephone Feature Card or the Modular ICS 6.0 System Coordinator Guide for more information.

Progrming pswds

You can choose any combination of six digits for Passwords.



Tip - *It is easier to remember the password if the digits spell a word.*

Some passwords allow line assignments to be rearranged, which could disrupt your telephone service. Provide passwords only to selected personnel to prevent unauthorized access to programming.

Installer

The default Installer password is **266344 (CONFIG)**.

1. Use CHANGE, the dialpad, and OK to program the Installer password.
2. Record the password in the *Programming Record*.



Tips - *You can choose any combination of one to six digits. It is easier to remember the password if the digits spell a word. Provide this password only to selected personnel to prevent unauthorized access to programming. The implications of such access may include the rearrangement of line assignments, which could affect the operation of the Norstar system.*

SysCoord+

The default System Coordinator Plus password is **727587** (SCPLUS).

Use **CHANGE**, the dialpad, and **OK** to program the System Coordinator Plus password.



Tips - *You should only distribute this password to experienced System Coordinators. This level of access is documented in the Modular ICS 6.0 System Coordinator Guide.*

An overview of what programming is available by using the System Coordinator Plus password is on page 280

SysCoord

The default System Coordinator password is **23646** (ADMIN).

Basic

The default Basic password is **22742** (BASIC).



Tips - *For more information about the System Coordinator and Basic passwords, see the Modular ICS 6.0 System Coordinator Guide.*

Registration password (MICS-XC only)

For more information about the Registration password, refer to the *Modular ICS Companion Installer Guide*.

Hospitality password

There are two passwords within the Hospitality feature. One provides secure access to the administration set for programming the service, and one provides secure access to a room condition setting from each room set for housekeeping staff.

Desk pswd

Change this password frequently, to maintain security.

At Hospitality:

1. Press .
2. Desk Pswd:4677 displays.
3. Press CHANGE.
4. New Pswd: displays
5. Enter a new password, then press OK.

Cond pswd

Change this password frequently, to maintain security.

At Hospitality:

1. Press .
2. Press .
3. Cond Pswd:None displays.
4. Press CHANGE.
5. New Pswd: displays
6. Enter a new password, then press OK.

Time&Date

The time and date shown on the telephone display is used by the system for scheduled features. It can be changed in programming or by using a feature code

(* * T I M E) or (* * 8 4 6 3).

For more information refer to the *Modular ICS 6.0 System Coordinator Guide*.

System prgrming

System prgming allows you to set up features and settings which are not associated with any specific line or telephone.

Hunt groups

The Hunt groups feature allows a group of sets to be called by a single directory number, ensuring that calls are easily routed to the appropriate group.

The default setting for Hunt groups is Broadcast. Hunt group statistics are available with **Usage Metrics** on page 541.

Hunt groups can be used to route calls to a support service such as a Help Line for a software company. Specialists dealing with Product A can be in one group. Specialists dealing with Product B can be in another group. Incoming calls will hunt for the next available set in the group. If no set is available, the call can be placed in a queue or can be routed to an overflow set.

The Hunt groups subheading in system programming is the area that programming changes are made to the following:

- members of a group
- member position in a group
- what lines are assigned to a group
- how incoming calls are distributed
- how long the system looks for available agents
- where a call goes if all agents are busy

The hunt group setting impacts other features:

- Call forwards set on telephones that are members of a hunt group are overridden by the hunt group routing.
- Sets that are members of a hunt group can temporarily leave a group by activating the DND feature.
- Wireless twinning can be enabled if a hunt group appears on the portable as well as the set.
- Priority calls to a hunt group will be rejected
- Hunt group set numbers cannot be in a ringing group.
- Hunt group set numbers cannot be in a page zone.
- Hunt group member line keys take precedence over Hunt group key, therefore, it is recommended that you do not assign any lines to telephones which are part of the hunt group. If you do assign lines to a hunt group telephone, ensure they do not duplicate any of the lines assigned to the Hunt Group DN.

Note: Videophones should not be programmed as members of a hunt group. Hunt groups allow one B channel connection at a time and videophones use two B channels.

Adding or removing members from a group

Members of the group can be any Norstar telephone or Business Series Terminal, CTA 500dm, ISDN set, or portables. A set can be in more than one hunt group but is considered a member in each hunt group, increasing the total number of members in the system.

There can be only one appearance of the same hunt group on a set. The appearance can be: Appr&Ring, Appr only, or Ring only.

The set number range for hunt groups is 707 to 736.



Tip - You must program the DNs for telephones you want to use for hunt group members outside the hunt group DN range.

Hunt groups can be programmed under **System Programming**.

1. Press . The display shows **Hunt groups**.
2. Press . The display shows **Show group#:**.
3. Enter the hunt group number you want to program (1-30).
4. Press . The display shows **Member DNs:**.
5. Press . The display shows the members for that group.
6. Press **ADD** to add a member or press **REMOVE** to remove a member from the group.
7. Select **APPEAR&RING**, **APPEAR only**, or **RING only** for the hunt group member. See *Appearances* on page 310.

Note: Fixed external cadencing is provided for all external hunt group calls regardless of whether or not they have been answered and transferred.

Moving members of a group

Member order within a hunt group is important. The member order determines how a call is routed through a hunt group.

1. Press **MOVE** to move an existing member to another place within the hunt group. The display shows the member number followed by an arrow.
2. Enter the new position number for the set.

Assigning or unassigning lines to a group

To avoid delayed ring transfer of external hunt group calls to a prime set, ensure that the hunt group line prime is set to **None**.

A line can only be assigned to one hunt group.

1. When the display shows **Member DNs:**.
2. Press . The display shows **Line assignment**.
3. Press . The display shows **Show line:**.
4. Enter the line number you want to program, press **SCAN** to go the first line assigned to this group, or press **LIST** to go to the first line in the system.
5. Press **CHANGE** to program the line as **Unassigned** or **Assigned**.

HGrr means the line is assigned to another hunt group.

Assigning a distinctive ring pattern to a Hunt Group

You can assign distinctive ring patterns to your Hunt Group so that calls can be rated in priority for the group.

These distinctive ring patterns, have the same characteristics as for line and extension distinctive ring patterns. Refer to *Programming distinctive ring patterns* on page 348.

The Hunt Group distinctive ring pattern determines how a call will ring within the Hunt Group. If members of the group have ring patterns assigned to their telephones that are higher than the ring patterns of the incoming line or the Hunt Group, then the Hunt Group will use the ring of the corresponding member telephones.

If the incoming call (line) has a higher ring pattern assigned, than the Hunt Group, the Hunt Group will ring with the line ring pattern.

1. Find the heading **Hunt groups**.
2. Press until the display shows **Member extns:**.
3. Press until the display shows **Dstinct Ring: NONE**.
4. Press **CHANGE** to toggle to the ring pattern number you want to assign to the Hunt group line. (**None, 2, 3, 4**)
5. Press to exit or to continue programming.

Setting the distribution mode

There are three modes of call distribution:

- **Broadcast** — rings each set in the group simultaneously. Calls are handled one at a time, other calls are queued. As soon as a call is picked up, the call next in the queue is presented to the hunt group without waiting for queue timeout.
In Broadcast mode, a single incoming call will ring simultaneously at all the sets in a group. This way, all receptionists in the group can share the load of answering large volumes of calls. A familiar example is a fund-raising campaign where a group of operators would be waiting to take each call as it comes in.
- **Sequential** — starts the call at the first set in the hunt group. Distribution is complete when the first free set has been found. Simultaneous calls can be presented. Distribution is order based.
In Sequential mode, you can program your top salesperson to be the first member of the group to receive calls.

- **Rotary** — the call starts at the set after the one which was last presented. Distribution is complete when the next free set has been found. Simultaneous calls can be presented. Distribution is order based.
In Rotary mode, you can ensure that all your help-line people are receiving calls, rather than one person receiving the majority of calls.

If a hunt group has available agents but nobody answers the call, the call is routed through the hunt group list until either someone answers the call or the queue timeout occurs. In the latter case, the call is diverted to the overflow position.

When the display shows **Member DNs:**.

1. Press until the display shows **Mode:**.
2. Press **CHANGE** to set the mode: **Broadcast**, **Sequential**, **Rotary**.

Setting the hunt delay

This setting allows you to program the number of rings the system permits at a hunt group set before moving on to the next set in the hunt group. This display only shows if the distribution mode is sequential or rotary.

1. When the display shows **Member DNs:**.
2. Press until the display shows **Hunt delay:**.
3. Press **CHANGE** to select the setting: 1, 2, 3, **4**, 5, 6, 7, 8, 9, 10.

Programming busy line setting

There are three routing options if all agents are busy:

- **BusyTone**—the caller gets a busy tone for PRI or BRI, otherwise the telephone rings back.
- **Overflow**—the call is routed to an overflow position. You can not use overflow if the overflow DN is a hunt group DN.
- **Queue**—the call stays in the system for a period of time. Within this period of time, the call will be presented to an agent if one becomes available. When the time-out occurs, the call will be presented to an overflow position.

1. When the display shows **Member DNs:**.
2. Press until the display shows **If busy:**.
3. Press **CHANGE** to set the mode: **BusyTone**, **Overflow**, **Queue**.

Programming the queue timeout

This setting allows you to program the number of seconds a call will remain in the hunt group queue before it is also routed to the overflow position.

1. When the display shows **Member DNs:**.
2. Press until the display shows **Q Timeout:**.
3. Press **CHANGE** to set the queue timeout: 15, 30, 45, **60**, 120 or 180.

Programming the overflow set

This setting allows you to program the overflow set the hunt group calls will be routed to when the queue is full.

- If the overflow set is not a hunt group set, the call ceases to be a hunt group call.
- If the overflow set is a hunt group set, the call is treated as a new call and goes to the bottom of the queue.

The overflow set also can be a set number associated with a voice mailbox.

1. When the display shows **Member DN#:**.
2. Press until the display shows **Overflow#:**.
3. Press **CHANGE** to change the overflow position.
4. Enter the new overflow position.

Setting the function name

This setting allows you to program the hunt group function name, such as Service or Sales. The name can be up to seven characters in length.

1. When the display shows **Member DN#:**.
2. Press until the display shows **Name#:**.
3. Press **CHANGE**.
4. Use the dialpad to enter the name of the hunt group.
5. Press to store the name.

Change DNs

Installer password required

Change DNs allows you to change the directory number (DN) or internal number of a telephone.



Changing DN locks programming session.

Changing an individual DN locks the programming session into the Change DNs programming mode. After you finish and press , re-enter the programming access code and the Installer password to continue with other programming.

Do not perform Startup again or all previous programming will be erased.

1. Use and the dialpad to identify the DN you want to change.
2. Use the dialpad to enter the new DN.

Featr settings

The following section describes how to configure set features.

Backgrnd music

Background Music allows you to listen to music through your telephone speaker. A customer-supplied music source must be connected to the Integrated Communication System.

Press CHANGE to select the setting: N (No) or Y (Yes).

On hold

On hold allows you to choose what a caller hears on an external line when the line has been put on hold.

Press **CHANGE** to select the setting: **Tones**, **Music**, or **Silence**.

- Tones provides a periodic tone.
- Music provides any signal from a source such as a radio connected to the ICS.
- Silence provides no audio feedback.

Receiver volume

Receiver volume allows you to specify whether the volume level of a handset receiver or headset will return to the system default level when a call is ended or put on hold, or whether the volume will remain at the level set at the individual telephone.

Use and **CHANGE** to select either: **Use sys volume** or **Use set volume**.

This feature is not available on some older telephones.

Camp timeout

Camp timeout delay allows you to assign the number of seconds before an unanswered camped call is returned to the telephone which camped the call.

Press **CHANGE** to select the setting: 30, **45**, 60, 90, 120, 150, or 180 seconds.

Park timeout

Park timeout allows you to assign the number of seconds before a parked call on an external line returns to the originating telephone.

Press **CHANGE** to select the setting: 30, 45, **60**, 90, 120, 150, 180, 300, or 600 seconds.

Park mode

The Call Park feature allows you to suspend a call. The call can then be retrieved at any system set by entering the unique retrieval code. Park Mode is the setting which determines how a retrieval code is assigned to parked calls.

Press **CHANGE** to select the way that the system will choose a Call Park code: **Lowest** or **Cycle**.

- When set to **Lowest**, the system will choose the lowest code that is available when the call is parked.
- When set to **Cycle**, the system will choose the codes in sequence, from lowest to highest, until all the codes have been used.

Trnsfr callbk

Transfer callback delay allows you to specify the number of rings before a callback occurs on a transferred call.

Press **CHANGE** to select the setting: **3**, 4, 5, 6, or 12 rings.



Tips - *You can estimate the delay in seconds if you multiply the number of rings by six.*

DRT to prime

Delayed Ring Transfer automatically forwards unanswered external calls to a prime telephone, after a certain period of time. This helps ensure that no external call goes unanswered.

Press **CHANGE** to select the setting: Ψ (Yes) or H (No).



Tips - *An operational prime telephone must be assigned before this feature can operate. A prime telephone is assigned to one or more external lines in the **Line Data** of programming.*

DRT delay

Delayed Ring Transfer delay allows you to specify the number of rings before a call is transferred to a prime telephone. For this feature to work, DRT to prime must be set to yes.

Press **CHANGE** to select the setting: 1, 2, 3, **4**, 6, or 10 rings.



Tips - *The DRT delay can be programmed only if DRT is activated.*
You can estimate the delay in seconds if you multiply the number of rings by six.

Held reminder

When active, Held Line Reminder reminds you that a call at your telephone is still on hold. You periodically hear two tones from your telephone until you return to the call on hold.

Press **CHANGE** to select the setting: H (No) or Ψ (Yes).

Remind delay

Held Line Reminder delay allows you to choose the number of seconds before the Held Line Reminder feature begins at a telephone that has an external call on hold.

Press CHANGE to select the setting: 30, **60**, 90, 120, 150, or 180 seconds.



Tips - *The Held Line Reminder delay can be programmed only if Held Line Reminder is activated.*

Directd pickup

Directd pickup allows you to answer any calls by specifying the internal number of the ringing telephone.

Press CHANGE to select the setting: **Y** (Yes) or **N** (No).



Tips - *Directed pickup is not to be confused with the Call Pickup Group feature in programming, which allows you to answer a call at any telephone within a specific group without specifying the internal number of the ringing telephone.*

Like Call Pickup Group, Directed pickup is useful when not all the telephones have been assigned the same lines, but you still want to allow your co-workers to answer a call on any external line from their telephones.

Page tone

You can choose whether a tone sounds before a page begins.

Press CHANGE to select the setting: **Y** (Yes) or **N** (No).

Page Timeout

The paging feature is automatically disconnected after a set length of time.

Press CHANGE to select the maximum number of seconds needed for a page: 15, 30, 60, 120, 180, 300, 600, **2700**.

Daylight time

When this feature is turned on, your system will automatically switch between standard time and daylight savings time.

Press CHANGE, to select the setting: **Y** (Yes) or **N** (No).



Tips - *The hour falls back one hour on the last Sunday of October at 2:00 am. It advances one hour on the first Sunday of April at 2:00 am. This function should only be programmed by your installer.*

In regions where daylight savings time does not apply, make sure this setting is changed to N (No).

AutoTime&Date

You can program the Automatic Time&Date feature to enable the Norstar system to automatically update the time and date after a power failure.

Whenever the clock is out of sync by more than two minutes as a result of a power failure or a loss of power, the first incoming call updates the clock automatically after two rings.

Note: CLASS trunks are required for this feature to work. Consult your customer service representative to determine if you have CLASS trunks.

This feature also allows the automatic changing between North American daylight savings and standard time. The Automatic Time and Date feature automatically overrides any manually-programmed changes to the time and date.

Note: The year is not included with the time and date information and must be programmed manually if the current year differs from the network time.

Press **CHANGE** to choose **Y** or **N**.

Setting SWCA controls

You can assign up to 16 System Wide Call Appearance (SWCA) keys to each telephone in a group. This is performed using the Key progrming heading under Terminals&Sets/User Preferences headings. SWCA controls are controlled by feature codes to . The user can also program this feature using these feature codes. Refer to the *Modular Plus System Administration Guide* for a instructions about programming features onto memory keys.

On the system, under **Feature Settings, SWCA Cnt.1** you define how incoming calls get associated to SWCA keys and how Hold will handle the calls.

The **Auto Associate** setting determines if answered calls will automatically be assigned to SWCA keys (**Auto Associate = Y**).

If you want the user to press the Hold button or a free SWCA key before the call transfers to a SWCA key, set **Auto Associate** to **N**. Calls remain assigned to SWCA keys for the duration of the call.

The **Invoke by Hold** setting determines if a SWCA call put on Hold can be picked up from other extensions in the group.

- If you want the call to be available to be picked up by other members of the groups when you put a call on Hold, set **Invoke by Hold:** to **Y**. A flashing indicator appears beside the SWCA key when the call assigned to that key is put on Hold.
- If you want calls to remain on Hold only at the telephone where the call is received, set **Invoke by Hold:** to **N**. Even if you set this field to **N**, users can still put selected calls on SWCA hold, by pressing a free SWCA key to put the call on Hold.

Refer to the System Coordinator Guide sections for information about assigning key programming and for instructions about using the keys.

1. Under **Featr settings**, press . The display shows **Backgrnd music:**.
2. Press until the display shows **SWCA Cntrl:**.
3. Press . The display shows **Auto Associate:N**.
4. Press **CHANGE** to choose the **Y** or **N** option.
5. Press . The display shows **Invoke by Hold:N**.
6. Press **CHANGE** to choose the **Y** or **N** option.
7. Press to exit or to continue programming.



Tips - *Since SWCA keys use the park feature, ensure that you have park turned on for your system by specifying a Park prefix (Access codes), and a park timeout setting (System programming, Featr settings).*

Call log space

Call log space programming customizes how log space is allocated to telephones in the system.

Reset all logs allows you to reallocate the Call log space equally to all telephones in your system.

1. Press **YES** and use the dialpad to enter the space allocation for the Call log at each telephone.

You must use a three-digit number (for example, 020 to give each set 20 spaces).

2. Press **YES** to accept the settings and end programming. The system automatically reallocates Log space.

Press **NO** to keep existing settings.



Tips - Use this heading only if you want to allocate an equal amount of log space to all the telephones in your system.

*If you want to assign specific amounts of log space to individual telephones, see the information under **Terminals&Sets** in the Modular ICS 6.0 System Coordinator Guide.*

Reallocating Call log space may destroy Call log data at telephones that lose space.



There are 600 Call log spaces available in the system. There are no spaces allocated by default.

*Changing the space allocation using Log Defaults defines the log space available to all telephones in the system. Any remaining unassigned log space is available in a log pool, and can be reallocated under **Terminals&Sets** in Telco features.*

Host delay

Installer password required

Host delay allows you to assign the delay between the moment an outgoing line is selected to make an external call, for example, by lifting the receiver off the telephone, and the moment that Norstar sends dialed digits or codes on the line.

Press **CHANGE** to select the setting: 200, 400, 600, 800, **1000**, 1200, 1400, 1600, 1800, or 2000 milliseconds.



Tips - *Host delay is provided to ensure that a dial tone is present before the dialing sequence is sent. Minimizing this delay provides faster access to the requested features.*

Link time

Installer password required

Link time allows you to specify the duration of a signal required to access a feature through a remote system.

Press **CHANGE** to select the setting: 100, 200, 300, 400, 500, **600**, 700, 800, 900, or 1000 milliseconds.

For example, to program external dialing through a Centrex system, which requires a Link time of 400 ms, specify a Link time of 400.



Tips - *The Link time required depends on the requirements of the host switching system that must be accessed.
Link is another name for Recall or Flash.*

AlarmSet

Alarm set allows you to assign a telephone on which alarm messages appear when a problem has been detected in the system.

1. Use **CHANGE** and the dialpad to enter the internal number of the Alarm telephone.
2. Press to set the Alarm telephone to **None**.

The default setting is **221**.

Set relocation

Set relocation allows you to move any telephone to a new location within the Norstar system without losing the directory number, autodial settings, personal speed dial codes, and any programming for that telephone.

Press **CHANGE** to select the setting: **N** (No) and **Y** (Yes).



Tips - *It is advisable to activate Set relocation after the telephone installation and programming is complete. This provides you with more flexibility in testing equipment.*

If this feature is deactivated while a telephone is moved, the internal number and programming data for that telephone remain with the physical port on the ICS, and the telephone does not receive the original programming when it is reconnected elsewhere.

Msg reply enh

The Message reply enhancement feature allows for the message waiting indicator on analog telephones connected to an Analog Station Module (ASM) to be deactivated automatically if the reply call from the analog telephone to the designated direct-dial telephone is answered, no matter where the call is answered from by the user.

This feature also functions if the user invokes the Call Pickup feature to answer the reply call from the analog set. It does not however, work with the Retrieve Parked Call feature.

Press **CHANGE** to select the setting: **Y** (Yes) and **N** (No).



Tips - *Direct-dial telephones are the only telephones that can send messages (using) to analog telephones connected to an Analog Station Module (ASM). The direct-dial telephone must be the designated direct-dial set for the analog telephone receiving a message.*

Answer key

Up to eight answer keys can be assigned per set. The Answer key setting in Feature settings allows you to determine what types of calls will alert at the telephone.

Answer key changes do not apply to portables.

Press **CHANGE** to select the settings: **Basic**, **Enhanced**, and **Extended**.

On the **Basic** setting answer keys do not ring for:

- Prime set call capture
- call forwarded calls
- other answer key calls
- priority calls
- voice calls
- ringing service
- callbacks

On the **Enhanced** setting is the same as the Basic setting except:

- answer keys will ring for overflow call routed calls (special case of Prime set call capture)
- answer keys will not ring for line transferred calls

On **Extended** all call types will ring except priority calls and voice calls.

Phantom DNs

A Phantom DN is the term used to describe a situation where a line is programmed to appear and ring on a set that does not physically exist. It allows you to create an Answer Key for the set that does not exist on an existing set. You would use a phantom DN in the case where you have taken a line out of service, such as a customer-response line, but you still get calls to that number. To handle the calls, create an answer key using the phantom DN on the set where you want these calls to be taken.

Clid match

This setting determines the minimum number of digits that an external call must match to an existing system speed dial number in order for the system to offer a name display for the CLID prompt if the system speed dial number is set up to display the caller name. Refer to the *Module Plus System Administrator Guide* for information about setting up System Speed Dials.

1. Under **Featr settings**, press . The display shows **Backgrnd music:**.
2. Press . The display shows **Backgrnd music: N**.
3. Press until the display shows **CLID match: 8**.
4. Press **CHANGE** to select the a number from 3 to 8, or select **None**, if you do not require any number matching.
5. Press to exit or to continue programming.

Direct-dial

Direct-dial allows you to dial a single system-wide digit that can be used to call a specific telephone, called a Direct-dial telephone. The most common example of a Direct-dial telephone would be telephone for an operator, a receptionist, or an attendant.

D-Dial 1

For the direct-dial telephone, indicate whether it is an internal or external number. A total of five Direct-dial telephones can be programmed on the system.

Use and CHANGE to select the setting: **Intrnl**, **Extrnl**, or **None**.

Intrnl/Extrnl#

Enter the internal or external number that the system will automatically dial when someone enters the direct-dial digit.

Use , CHANGE, and the dialpad to enter the telephone number.

The default number for the direct-dial telephone is **221**, on the default three-digit DN system.

Line selection

If you assign an external number as a direct-dial telephone, you must indicate which line to use for the call.

Use , CHANGE, and the dialpad to select the line for the external number.



Tips - *There is just one direct-dial digit for the entire system.*

The Norstar system cannot verify that the number you assign as an external direct-dial telephone is valid. Check the number before assigning it, then call the direct-dial telephone after you've assigned it to test it.

You cannot forward calls to any direct-dial telephone that is outside your Norstar system. For more information, refer to the Modular ICS 6.0 System Coordinator Guide.

CAP assignment

Installer password required

This setting designates a telephone as a central answering position (CAP). The CAP must be an M7324 telephone, and may have one or two CAP modules attached. A maximum of five CAPs can be installed in a Norstar system.

The CAP may be used to:

- monitor the busy/not busy and Do Not Disturb status of Norstar telephones
- answer external calls on up to 120 lines, and extend calls to other Norstar telephones
- send up to 30 messages to other Norstar telephones
- provide up to 96 extra memory buttons for the M7324 telephone

Use , **CHANGE** and the dialpad to enter the internal number of the M7324 telephone to be designated a CAP.



Tips - *If CAP modules are attached to an M7324 telephone that has not been programmed as a CAP, then no CAP settings are assigned. If a CAP module is relocated with the M7324 telephone, the settings are retained.*

A station auxiliary power supply (SAPS) is required for M7324 telephones that have one or more CAP modules attached.

Dialing Plan

Installer password required

The dialing plan acts as a system directive that determines how a number will be dialed out by the system. This feature works with enbloc dialing, and, therefore, is only used for PRI lines.

The Dialing Plan has these features:

- allows public or private routing for network calls
- private routing allows the choice of either the uniform dialing plan (UDP) or a coordinated dialing plan (CDP)
- allows enbloc dialing by buffering user-dialed digits until a complete DN has been dialed. Enbloc dialing is a requirement for PRI.
- provides the ability to map user-dialed digits to a service type on a Call by Call basis
- allows incoming calls to be routed according to the service type and the digits received

DN lengths (enbloc dialing)

The Private DN Length must be set to the number of digits users dial to reach other nodes in a private network. The Private DN Length parameter is used by the PRI trunk to

determine when a complete number has been dialed. The PSTN DN Length Table is used by the PRI trunk to determine when a complete PSTN DN has been dialed. Entries in the DN Length table consist of two fields: Prefix and DN Length.



TIP - *You do not need to use a Private DN Length if you are using the coordinated dialing plan, as the system identifier is part of the set DN.*

Defining dialing plans:

At **System Prgrming/Dialing Plan**:

1. Press . **Private Network:None** displays.
2. If you are defining a dialing table for a private network, press . Refer to *Private networks* on page 413.

If you are defining a dialing table for external (public) DNs for a network, press . Refer to “Public networks” on page 415.

Private networks

Private network: None

Choosing this setting turns off MICS functionality.

1. At **Type:None**, press .
Priv DN len:4 displays.
2. Press **CHANGE** to choose a new private DN length. (3-14)

Private network: CDP

If your dialing plan needs to use steering codes to navigate to other networks, specify a coordinated dialing plan (CDP).

1. At **Type:None**, press CHANGE until **CDP** displays.
2. Press **Next** . **PrivNetID:1** displays.
3. Press CHANGE, and enter a new private network id.

Note: If you are specifying a private network that has been created using SL-1 (MCDN) lines, the private network id is part of the set DN (for instance, system A might have DNs from 3201 to 3299, whereas system B might have a DN range starting with 2, such as 2201 to 2299). However, you must enter a number, so enter the number that appears first on the set DNs.

This code is defined by the network coordinator and must be unique to each system.

4. Press **Next** . **Priv DN len:3** displays.
5. Press CHANGE to choose a new private DN length. (3-14).

Note: The Private DN length must match the DN lengths being used by the other systems in the network. This is what enbloc dialing uses to determine when the complete number has been dialed.

Private network: UDP

If your dialing plan will be using Location codes to navigate to other systems, specify a uniform dialing plan (UDP).

1. At **Type:None**, press CHANGE until **UDP** displays.
2. Press **Next** . **PrivNetID:1** displays.
3. Press CHANGE, and enter a new private network id.
4. Press **Next** . **Loc code:None** displays.

5. Press **CHANGE** and use the dialpad to enter a location code.

Note: This code must be unique to your system.

6. Press . **Priv DN len:3** displays.

7. Press **CHANGE** to choose a new private DN length. (3-14)

Note: The Private DN length must match the DN lengths being used by the other systems in the network. This is what enbloc dialing uses to determine when the complete number has been dialed.

Public networks

When you identify public DN's on a network, use the Dialing Rules to define any prefixes that need to be dialed out. The public network refers to connections to the public switching network (PSTN).

1. At **Public Network**, press .

Pub DN lengths displays.

2. Press . **PrivNetID:1** displays.

3. Press . **Show Prefix:** displays.

4. Press **ADD** and enter a prefix.

5. Press **OK** to accept the prefix.

6. Repeat steps 4 and 5 until all the prefixes have been added.



Tip - *If you want to view the prefix list, at the Show Prefix: display, press .*

*To remove a prefix, find the prefix, then press **REMOVE**.*

Dial Timeout

Dial Timeout (interdigit timeout) specifies how long the ICS will wait between user-dialed digits. This value allows the ICS to determine when the user has stopped dialing. The value is programmed under **System Programming, Dialing Plan**.

The user can also use the # key to tell the ICS that they are finished dialing. However, this is not usually required except for international calls where the number of digits dialed for country codes varies.

With the display showing **System Programming**

1. Press then press until **Dialing Plan** displays.
2. Press then press until **Dial timeout** displays.
3. Press **CHANGE** to select a the timeout value (3, 4, 5, 6, 8, 10, 15) in seconds.

Too small a timeout value forces the user to enter the digits very quickly one after the other.

Too large a value causes the system to wait for a long time after the last digit is entered before the call is dialed out.

For more information on non-PRI routing tables and destination codes, refer to *Routing service* on page 361.

Access codes

Installer password required

Access codes are used by the system to direct calls to the correct lines and destinations. If the codes conflict, some of the features on the system will not work.

The table of default settings can help you plan your access codes so there are no conflicts.

Digits assigned by default to settings

Digit	Use	Heading
0	direct-dial digit	Access Codes
1	Park prefix	Access Codes
2	the first digit of B1 DNs	Startup
9	line pool A access code Takes precedence over the External Line access code if there is a conflict.	Access Codes
— —	external line access code	Access Codes
— —	destination code	Routing Services

Line pool codes

Installer password required

This setting allows you to assign a line pool access code for each of the 15 line pools (A to O). These codes are used to specify the line pool you want to use for making an outgoing external call.

If your system is installed without expansion cards, the DN default is two digits. Therefore, B1 DNs will be from 21 to 52 and the B2 DNs are assigned from 53 to 84. The B2 DN range is 80 to 84. Therefore, the single digit 8 is not available for a line pool access code.

Use , **CHANGE**, the dialpad, and **OK** to program the access code.

The default access code is 9 for Line Pool A, and None for Line Pool B-O.

For ISDN-PRI, see *Line Pools* on page 436.



Tips - *The code can be one to four digits in length.*

A line pool access code can be the same as an external line access code. In this case, the line pool access code takes priority over the external line access code, and a line from the line pool is selected.

A line pool access code cannot conflict with: the Park prefix, the Direct-dial digit; the first digit of any Received number; the first digit of any DN (including the Auto DN or the DISA DN).

To avoid a conflict, refer to the table of default settings in the description of External code.

Park prefix

Installer password required

The Park prefix is the first digit of the call park retrieval code that must be entered to retrieve a parked call. If the Park prefix is set to None, calls cannot be parked.

Press **CHANGE** to select the setting: **1** to **9**, **None**, or **0**.



Tips - *The Park prefix cannot be the same as:*

- *the Direct-dial digit*
- *the External Line access code*
- *the first digit of a DN*
- *the first digit of a line pool access code*
- *the first digit of a destination code*

Other programmable settings may affect which numbers appear on the display during programming. Although the numbers 0 to 9 are valid Park prefix settings, some may have been already assigned elsewhere by default or by programming changes. To avoid a conflict, refer to the table of default settings in the description of External code.



If DN length is changed, and the changed DN's conflict with the Park prefix, the setting changes to None.

SWCA note: If you want to use system wide access (SWCA) keys on your system, you must specify a Park Prefix to turn on the feature.

External code

Installer password required

External code allows you to assign the external line access code. This code is used to allow M7100, T7100 sets, and Analog Terminal Adapters (ATA2) to access external lines.

Press **CHANGE** to select the setting: 0 to 9, or **None**.



Tips - *The external line access code cannot conflict with:*

- *the Park prefix*
- *the direct-dial digit*
- *the first digit of a line pool access code*
- *the first digit of a DN*
- *the first digit of a destination code.*

If DN length is changed, and the changed DN's conflict with the Park prefix, the setting changes to None.

Direct-dial

Installer password required

Direct-dial digit allows you to dial a single system-wide digit to call a specific telephone, called a direct-dial telephone.

Press **CHANGE** to select the setting: 1 to 9, **None**, or **0**.



Tips - Another direct-dial telephone, an extra-dial telephone, can be assigned for each schedule in Services programming. The direct-dial digit cannot be the same as the first digit of:

- a DN
- a line pool access code
- the external line access code
- the Call Park prefix
- the first digit of a destination code

If DN length is changed, and the changed DNs conflict with the Park prefix, the setting changes to None.

Auto DN

Installer password required

For calls answered without DISA, no password is required to access the Norstar system. The Class of Service (COS) that applies to the call is determined by the COS for the trunk on which the user is calling.

1. Use **CHANGE** and the dialpad to enter the digits to be received from the auto-answer trunk.
2. Press **CLR** to set the Auto DN back to **None**.



Tips - The length of the Auto DN is the same as the Rec'd # length specified in **System Prgming**. The Auto DN is cleared if the Received number length is changed.

The Auto DN cannot be the same as a line pool access code or a destination code.

DISA DN

Installer password required

For calls answered with DISA, the system presents a stuttered dial tone to prompt a caller to enter a valid password. The Class of Service (COS) that applies to the call is determined by this COS password.

Once a remote user is on the Norstar system, the DISA DN can be used to change the existing Class of Service. This gives you greater flexibility when you create access privileges. For example, you may want to have a shared DN for remote access and separate COS passwords with different dialing out privileges for individuals.

Use **CHANGE** and the dialpad to enter the digits to be received from the auto-answer trunk.

Press **CLR** to set the DISA DN to None.



Tips - *The length of the DISA DN is the same as the Rec'd # length specified in **System prgrming**. The DISA DN is cleared if the Received number length is changed.*

The DISA DN cannot be the same as a line pool access code or a destination code.

PrivAccCode

Installer password required

If you have created a Private or Tandem network, you need to provide a specific code to access the network links.

1. Press **Change** and use the keypad to enter a code.
2. Press **OK** to save the code.

This code must not conflict with any other access code or call code within the system.

Assign this code as the destination code for the private line or line pool that connects to the next node in the network.

Carrier Codes

Installer password required

If you are routing calls with different carriers as you change schedules, you need to be able to define the access codes for each carrier you use.

A multi-digit Carrier Access Code (CAC) contains an Equal Access Identifier Code (EAIC) followed by a Carrier Identification Code (CIC). The CIC identifies the carrier to be used to handle the call. The Carrier Access Code table stores the CAC digit pattern that you define for your region.

In most cases it is not necessary to change the default values. The capability is there to modify overall patterns, if required.

- you can define up to five entries
- two entries will be pre-defined in North America, but you can remove these defaults
- each entry consists of an EAIC prefix (one to six digits) and a CIC length (one digit, 1 - 9)
- each entry is identified by the prefix digits themselves

This code becomes part of the External Number field in Route programming that will be used to access the carrier. Refer to *Adding a long distance carrier access code* on page 375.

1. From the **Access code** menu, press **Next** until you reach **Carrier Codes**.
2. Press **Show** . **Prfx:10** appears.
3. **Add** or **Remove** prefixes, as you require.
4. Press **Show** . **ID length:3** appears.
5. **Change** the length of the prefix, as you require.

This code must not conflict with any other access code or call code within the system.

Remote access

Remote access packages allow you to control the remote use of Norstar line pools. Create a remote access package by defining which of your system line pools will be able accessible. You then assign the package to individual lines (using **Rem line access**), and to a particular Class of Service password (**Remote Pk9** in **COS Passwords**).

Rem access pkgs

Use and the dialpad to select the remote access package you want to program.

LinePool access

Press **CHANGE** to select the line pool access setting for each pool: **N** (No) or **Y** (Yes).

Remote Page

Press **CHANGE** to select the remote paging setting for each pool: **N** (No) or **Y** (Yes).

Rem line access

Enter the number of the line which will be accessible by remote users.

L001 Rem Pk9

Press **CHANGE** and enter the number of the remote access package remote users accessing the line will be able to use.

Remote access packages defaults

Parameter	Square	PBX	Hybrid	Centrex	DID
Package 00	Prohibits remote access to line pools, Page, remote monitoring and administration. Cannot be changed.				
Package 01 Line pool access	Y for Pool A N for Pools B to O and PRI-A and PRI-B				
Packages 02 - 15 Line pool access	N for Pools A to O and PRI-A and PRI-B				



Tips - You can use COPY and the dialpad to copy settings from one remote package to another.

The line pool access display shows an alphabetic line pool identifier, followed by a numeric line pool access code in brackets, for example, Pool1A (9)N. If no access code has been identified, there is nothing between the brackets.

For example Pool1A ()N.

The line pool access code can be programmed under **Terminals&Sets**.

Remote package 00 is the default setting and cannot be changed.

You can define up to 15 remote access packages (01 to 15).

Changing Companion DN type

Installer password required

This Companion setting is applicable for MICS-XC 6.0 systems.

On startup, the DN default ranges are:

- desk sets: 221-605
- portable sets (Companion): 637-666
- ISDN devices: 667-696
BRI S-loops may have more than one DN associated to each loop.

Note that the DN range 637 to 696 can be used by either portable telephones or ISDN S-loops.

- You can assign all 60 of the DNs to portable telephones and none to S-loops.
- You can assign up to 30 DNs to S-loops, leaving 30 for portable telephones.

Within these two limits you can choose a combination of ISDN and portable telephone DNs.

If you try to assign more than 30 ISDN DNs, ~~Max 30 ISDN DNs~~ will appear.

Before you change a registered portable telephone DN to an ISDN DN, you must first deregister the number. Refer to *Modular ICS Companion Installer Guide*.



Tips - *When you change an S-loop DN to a portable telephone DN, service could be disrupted on one of the S-loops. If you want to change the DN type while people are using the Norstar system, use the Page feature (), to announce that calls may be disconnected.*

1. Press **CHANGE** to select the DN type setting: **ISDN** or **Portable**.
2. Press **STATE** to show whether the number is: **Assigned**, **Registered**, **Available**, **Pending**, or **In use by system** (currently being used by an ISDN device).

If an ISDN DN is being changed, the display may show **Disrupt service?** Press **No** to leave the value as ISDN, or **Yes** to remove the ISDN DN from use by the system.

Note: If you change an ISDN DN that has a device already assigned, the device will fail. To fix this issue: return the DN to ISDN and unplug and replug the device. For this reason, changing DNs should only be done when the system is not busy.

Rec'd # length

Installer password required

The Received number length setting allows you to change the number of digits received on auto-answer trunks. These digits are used to identify target lines, Auto DNs, and DISA DNs.

Press **CHANGE** to select the setting: 1, 2, **3**, 4, 5, 6, or 7. Then, press to make the change.



Tips - *The target line number (for example, line 052) and the Received number for the target line (for example, Rec'd #: 123 for line 052) are two different numbers.*



Tips - *The Received number length may be the same as the system DN length. However, network or central office constraints may require you to set it to some other value.*

Changing the Received number length causes all programmed received digits to be cleared.

DN length

Installer password required

This feature allows you to change the number of digits for all DNs. The maximum length is seven. The default, and minimum length, is **3**.

1. Press CHANGE to select the setting: **3**, 4, 5, 6, or 7.
2. Press to save the new DN length.

The display shows **Drop data calls?**.

3. Press YES to save the new DN length.
NO restores the original value.



Tips - *A DN length change, if required, should be the first programming change on a newly-installed Norstar system.*

Each increase in length places the digit 2 in front of any existing DN. For example, if DN 234 was increased to a length of 4, the new DN would be 2234.

If the DN length is changed so that a conflict is created with the Park prefix, external line access code, direct-dial digit, or any line pool access code, the setting for the prefix or code is changed to None, and the corresponding feature is disabled.



Do not change DN length immediately after a system startup.

You must wait for at least two minutes after a system startup before you change the DN length.

Data devices which use the B2 channel drop calls when the DN length is changed. Norstar telephones and Business Series Terminals T7100, T7208, and T7316 retain their calls because they only use the B1 channel.

The DN length change is completed within two minutes, depending on the size of the installed Norstar system. System response may briefly slow down during this time. You cannot re-enter programming during this time. If you enter the programming access code, the message `In use: SYSTEM` appears on the display.

Nat'l length (profile 2, only)

Installer password required

This feature allows you to change the number of digits that the system will expect to see for a national telephone number.

1. Press CHANGE to select the setting: (default is 10).
2. Press YES to save the new DN length.

Make/Break (profile 2, only)

Installer password required

This feature allows you to change the ratio of your system.

1. Press CHANGE to select the setting to either 40/60 or 30/70.

BusName

Norstar will display the name of the calling party when it is provided both Private or Public ISDN PRI and BRI interfaces. The displayed name may include information such as the Receiving Calling Name, Receiving Redirected Name, and/or Receiving Connected Name. The outgoing name is the business name concatenated with the set name.



Tip - *The outgoing name is not supported on BRI.*

Refer to Feature assignment (CLID alignment) on page 330.

Network Name Display is an optional feature that is available based on the interface to which you are subscribed.

Network name display supported by protocol

Feature	Interface			
	NI PRI	DMS Custom PRI	NI BRI	SL-1
Receiving Calling Name	Supported	Supported	Supported	Supported
Receiving Redirected Name	Supported		Supported	Supported
Receiving Connected Name		Supported		Supported
Sending Calling Party Name	Supported	Supported		Supported
Sending Connected Name		Supported		Supported

Receiving and Sending Calling Party Name

Network name display allows the name of an incoming PRI/ BRI call to be displayed on the Norstar set receiving the call.

- Calling Party Name with status of **PRIVATE** may be displayed on the Called Party set as **Private name**.
- If the incoming Calling Name is defined by the CO as a private name, then **Private name** appears on the answering set.

- If the Calling Party Name is unavailable it may be displayed on the Called Party set as **Unknown name**.
- The system supports sending the calling party name, which is the Business Name and Set Name concatenated together, on calls originated by the Norstar system.

For information on programming your Feature assignment, see *Feature assignment (CLID alignment)* on page 330.

The Set Name will only be sent if the OLI for the Set is configured. See *OLI #* on page 315.

Receiving and Sending Connected Name

Outgoing calls record the Connected Name on outgoing calls. The Connected Name is stored and displayed on the Norstar set. In order for this to work you need to set the Called ID to Yes. See *Called ID* on page 332.

The system also supports sending the Connected Name, which is the Business and Set Name concatenated together, with incoming calls.

If the call is answered by a hunt group, the hunt group name is used instead of the set name.

The Connected Name is a transient display that appears for about three seconds.

Network Name Display interactions

Calling and Connected Name information (if available) is passed between trunks with Selective Line Redirection (SLR). Only Calling Name information is passed between trunks in cases where Direct System Inward Access (DISA) has resulted in tandeming of trunks.

Programming Network Name Display

The Business Name and the Set Name make up the information that is used for the outgoing Calling name or connected name.

Calling/connected name is only sent once the Business Name is programmed.

To program the Business Name start with the display showing **System Prgrming**.

1. Press .The display shows **Hunt Groups**.
2. Press until the display shows **BusName:**.
3. Press **CHANGE** and use the keypad to enter a Business Name. You can enter a maximum of eight letters. It is recommended that you use a blank space for the last character to act as a separator between the Business name and Set name.

To program the Set Name start with the display showing **Terminals & Sets**.

1. Press and enter the set number of the telephone you would like to program.
2. Press . The display shows **Line access**.
3. Press until the display shows **Name:**.
4. Press **CHANGE** and use the keypad to enter a Set Name. You can enter a maximum of seven letters.
5. Other areas that must also be programmed include:
 - the OLI number, see *OLI #* on page 315
 - under Telco features the Call ID must be set to yes, see *Called ID* on page 332

Outgoing Name and Number Blocking

When activated, blocks the outgoing name and number on a per call basis. When this feature is used, the call is flagged to the CO so that the name and number will not be presented to the person being called.

On analog and BRI trunks, a call blocking digit sequence is sent to the CO before sending the dialout digits. You can change this digit in a Norstar programming session and set it to the digit sequence recognized by the local CO for name and number blocking.

This programming is done in the main program heading **Telco Features**. To program the Name and Number blocking digit, start with the display showing **Telco features**.

Note: Step 1 through 3 are only for analog and BRI trunks.

1. Press . The display shows **UMs9 ctr tel#s**.
2. Press until the display shows **ONN Blocking:**.
3. Press . The display shows **Tone:None**. You can choose **F78, (0-9), *, #**.
4. Press **CHANGE** to enter a new tone dialing Name and Number blocking digit sequence.
5. Press . The display shows **Pulse:None**. You can choose **F78, (0-9), *, #**.
6. Press **CHANGE** to enter a new pulse dialing Name and Number blocking digit sequence.

Call by Call service selection for PRI

Installer password required

Call by Call service selection allows a user to access services or private facilities over a PRI line without the need for dedicated facilities. The different services represent different types of access to the network. Various services are available depending on the chosen protocol. The list below identifies the supported services

Call by Call service selection is supported for the following protocols:

- National ISDN 2 (NI-2)
- DMS-100 custom
- DMS-250 (MCI, Sprint, Generic)
- AT&T 4ESS custom

The following Call by Call Services are supported:

Public	Public calls connect Norstar and a Central Office (CO). Both incoming (DID) and outgoing (DOD) calls are supported. Dialed digits conform to the standard North American dialing plan (E.164 standard).
Foreign Exchange (FX)	Foreign exchange service connects a Norstar site to a remote central office (CO). This provides the equivalent of local service at the remote location.
Tie	Tie lines are private incoming and outgoing lines that connect Private Branch Exchanges (PBXs) such as Norstar.

OUTWATS (Outward Wide Area Telecommu- nications)	This outgoing call service allows a Norstar user to call telephones in a specific geographical area referred to as a zone or band. Typically a flat monthly fee is charged for this service.
INWATS (Inward Wide Area Tele- communica- tions)	This long distance service allows a Norstar user to receive calls originating from specified areas without charge to the caller. A toll-free number is assigned to permit reverse billing.
International INWATS	An international long distance service that allows a Norstar user to receive international calls originating from specified areas without charge to the caller. A toll-free number is assigned to permit reverse billing.
Switched Digital	This service provides premises-to-premises voice and data transport with call management and monitoring features.
Nine Hundred	This service is commonly referred to as fixed charge dialing.
Private	Private incoming and outgoing calls connect Norstar to a virtual private network. Dialed digits may conform to the standard North American dialing plan (E.164 standard) or the dialed digits may use a private dialing plan.

Norstar supported Call by Call Services by protocol

Norstar Service ^a	NI-2 ^f	DMS-100 (custom)	DMS-250 (MCI, Sprint, Generic)	AT&T 4ESS
FX	FX	FX ^b		
Tie^c	Tie	Tie	Tie	SDN (software defined network)
INWATS	INWATS	INWATS	Eight Hundred	Toll Free MEGACOM
International INWATS	Same as INWATS	Same as INWATS	Same as INWATS	International Toll Free Service
OUTWATS	IntraLATA OUTWATS OUTWATS with bands InterLATA OUTWATS	OUTWATS	PRISM	MEGACOM
Private		DMS Private ^e	VNET (virtual network)	
Switched Digital				ACCUNET ^d
Nine Hundred			Nine Hundred	MultiQuest
Public	Public	Public	Public	

- A shaded box indicates that the protocol does not support the service.
- DMS-250 Sprint and UCS support incoming FX only (i.e. Network-to-Norstar). DMS-250 MCI does not support FX.
- NI-2 allows two Tie operating modes: senderized and cut-through. Norstar will only support senderized mode.
- Rates greater than 64 kbps will not be supported.
- Bell Canada VNET.
- Not all service types may be supported by a switch type. For information, contact your service provider.

Programming Call by Call on PRI requires you to program various areas of the Norstar system:

- under **Line access**, assign the line pool
- under **Services**, in routing services section, assign which pool to use for routing and which service type service id, if required

- under **System Programming**, specify the minimum and maximum values for the pools
- under **Hardware** choose PRI card and select the protocol

Line Pools

All lines in a PRI interface are in the same PRI line pool. This pool cannot contain any non-PRI lines. There is one PRI pool available for each PRI interface on the CSU.

Depending on the order that the cards are configured as PRI, Pool PRI-A represents lines 1 to 30, and Pool PRI-B represents lines 31 to 60. If both PRIs are connected to the same service provider and use the same protocol, lines 1 to 30 and 31 to 60 can be put in the same pool. There are four PRI pools available for profile 1 and 4 systems, PRI-A, PRI-B, PRI-C, PRI-D because these profiles support the off-core DTI module.

Programming Call by Call service selection

Programming the Norstar system for Call by Call Service Selection with a PRI interface requires

- provisioning a PRI card if a PRI card is not already a part of the system, on page 456
- selecting a protocol, on page 456
- programming incoming call routing, on page 458
- programming routes that use the PRI pools (under **Services**), see *Routing service* on page 361

PRI Call by Call Limits

PRI pool limits for Call by Call services allows you to configure limits for service types without interacting with the CO. This feature sets the minimum and maximum number of incoming and outgoing calls per service type for the PRI pool.

The number of active calls will be tracked so that whenever a call is being set up, a check will be made to determine if it will be allowed. Calls will not be allowed if they exceed the maximum value for that service type or if they will use lines needed to maintain the minimum value of other service types.

The summation of the minimum values for incoming or outgoing PRI services cannot exceed the total number of lines in the PRI pool.

The maximum value for an incoming or outgoing PRI service cannot exceed the total number of lines in the PRI pool.

Programming Call by Call Limits

With the card set to PRI and the display showing **System prgrming**.

1. Press .The display shows **Hunt groups**.
2. Press until the display shows **CbC limits**.
3. Press .The display shows the first pool (PRI-A or PRI-B) that supports CbC routing. Press **NEXT** to show the other pool, if it is available.
4. Press .The display shows **Service:**. The service that is displayed depends upon the protocol. Press **NEXT** to select a different service.
5. Press . If it applies, the display shows **Min incoming:2**. Press **CHANGE** to enter a different number.

6. Press . If it applies, the display shows **Max incomin9:23**. Press CHANGE to enter a different number.
7. Press . The display shows **Min out9oin9:4**. Press CHANGE to enter a different number.
8. Press . The display shows **Max out9oin9:23**. Press CHANGE to enter a different number.

Release Reasons

This feature is useful for diagnostic purposes. It shows the reason why an ISDN call has been released. The Release Reason can be displayed as Simple or Detailed text. When the default **None** is selected, no release reasons appears on the set.

Release Reasons can be programmed under System prgming. With the display showing **System prgming**.

1. Press until the display shows **Release reasons**.
2. Press . The display shows **Text: None**.
3. Select the text to be displayed as **Simple** or **Detailed**.

Note: If you selected Simple text, press for Cause code. The **Cause code** is for diagnostics. Make sure it is set to **N**.

Mk/BR: 40/60 (profile 2 only)

This heading sets the make-break ratio for the system.

1. Press until the display shows **Mk/BR**.
2. Press CHANGE and select either **40/60** or **30/70**.

Programming Hospitality Services

The Hospitality heading accesses the settings for the room and alarm information.

With the display showing **System Prgrming** press until the display shows **Hospitality**.

Room/desk information

Use this setting to assign set DNs to a specific room.

1. At the **Hospitality** heading, press .
Room/desk info displays.
2. Press . **Show set: displays**.
3. Enter a room set number or press **LIST** and press until you find the DN of the set you want to assign to a room.
4. Press . **Room #:None** displays.
5. Press **CHANGE** and enter the room number, then press **OK** to accept the change.
6. Repeat step 6 for all the sets you want to assign.
7. Press . **Adm Fwd read:Y** displays
8. Press **CHANGE** and choose **Y** or **N**, depending on your security requirements.

Call restrns

You can set up call restrictions based on room occupancy states. This setting affects the Room occupancy feature.

1. At the **Hospitality** heading, press twice. **Call restrns** displays.
2. Press . **Vacant:00** displays.
3. Press **CHANGE** and enter the filter that defines the restrictions for your hospitality system. Refer to *Filters* on page 322
4. Repeat steps 2 and 3 for the other room occupancy states.

The table below shows an example of a call restrictions setup.

Room Occupancy	Filter	Description
Vacant	11	no calls allowed except 911
Basic	11	no calls allowed except 911 and internal extensions
Mid	12	no calls allowed except 911, 1800, 188 and internal extensions
Full	13	no call restrictions

Setting Service times

You can set the time when occupied rooms change from Service done to Service required. This setting affects the Room condition feature.

1. At the **Hospitality** heading, press until **Service time** displays.
2. Press . **Hour: 00** displays.
3. Press **CHANGE** and enter the hour (00 to 23).

If the number is less than 13, the display shows **AM**. Press **CHANGE** to select **PM**, if required. Press **OK** to accept.

4. Press . **Minutes: 00** displays.
5. Press **CHANGE** and enter the minutes (00 to 59).

Configuring alarms and expired alarms settings

Use this feature to create the alarm settings that will govern the alarm features for both the administrative and room sets.

1. At the Hospitality heading, press until **Alarm** displays.
2. Press . **Attn attempts:3** displays.
3. Press **CHANGE** until you find the number you want (1-5).
4. Press . **Retry intrvl:4** displays.
5. Press **CHANGE** until you find the number you want (2, 4, 6, or 8).
6. Press . **Attn duration: 15** displays.
7. Press **CHANGE** until you find the number of seconds you want (10, 15, 20, 30, 40, 50).
8. Press . **Time format:12 hr** displays.
9. Press **CHANGE** to choose either **12hr** or **24hr**.
10. Press . **Expired alarms** displays.
11. Press . **Notify set:None** displays.
12. Press **CHANGE** to enter a set DN to be notified.
13. Press . **Use tone:N** displays.
14. Press **CHANGE** to choose either **Y** (yes) or **N** (no).

Network Services

The headings that appear under Network Services, depends on which profile the system is running.

Profiles 2 allows ETSI line connections, therefore, systems running this profile may have access to the two ETSI features. The service provided on the line by your service provider determines if these features are available.

Profiles 1, 2, and 4 support MCDN over PRI SL-1 lines.

ETSI: Network diversion and MCID (profile 2 only)

If you are using Profile 2 for your system, and your service provider supports the features, you can configure your ETSI PRI lines to allow network diversion and/or MCID recording.

To program these features:

1. With the display showing **System Prgrming** press until the display shows **Network Services**.
2. Press . **ETSI** displays.
3. Press . **Network Redirection** displays.
4. Press **CHANGE** to choose either **Y** (yes) or **N** (no).
5. Press . The display shows **MCID**.
6. Press **CHANGE** to choose either **Y** (yes) or **N** (no).

Network Call Diversion

Norstar Network Call Diversion (NCD) is a network function that allows forwarding and redirection of calls outside the Norstar network when using an ETSI ISDN line. Functionality is similar to that of External Call Forward (ECF).

NCD redirects calls using the same line on which they arrive. Call forward is efficient since there is no need for additional outside lines.

Forwarding calls externally from an extension requires the user to enter either a Destination Code or Line Pool Access Code, and the number to which calls will be forwarded.

Examples of NCD include:

- redirecting all calls from an extension to a mobile phone
- forwarding calls to an external destination (rather than to voicemail), when an extension is busy or the user is unavailable.

Feature description

NCD is available only over ETSI ISDN lines. It can be invoked when calls are presented to Norstar/BST extensions over ISDN lines. The user must program the selected extension.

NCD is integrated with the following existing Norstar Call Forward features:

- Call Forward Unconditional (CFU)—implemented on Norstar Call Forward All Calls (CFAC) 4, and Selective Line Redirection (SLR) 8 4, also referred to as Line Redirection. This is programmable by the user.

- Call Forward on Busy (CFB)—implemented on Norstar Call Forward Busy.
- Call Forward on No Response (CFNR)—implemented on Norstar Call Forward No Answer.

Programming and restrictions

NCD features are accessed through existing Norstar features. Extensions requiring redirection must be programmed individually to either CFAC or SLR. CFB or CFNA must be set during programming. `Allow redirect` must be set to `Yes` for each extension, in `Terminals&Extns/Capabilities`.

Note: Any other programming applied to specific lines and extensions take precedence, for example `Restrictions(extns)` under `Terminals&Extns`.

NCD is used as long as the affected lines are ETSI ISDN, and the affected DID lines are accessible via ISDN lines. Incoming calls are diverted back to the ISDN. If NCD fails due to network errors, ECF is invoked. If ECF cannot be executed, the incoming call is routed to the prime extension for the line.

ATTENTION!

If a line is configured to appear on several extensions with redirection programmed, predicting which extension will divert the call is not possible. This should be considered during system configuration.

An extension with CFB, CFNA and CFAC programmed will give priority to CFAC for diversion.

Malicious call identification (MCID)

The MCID feature allows the user to press to have call information recorded on the central office system for an incoming call on a specific line (ETSI PRI lines, only).

The user must invoke the feature code either during the active call or within 30 seconds (time varies on different networks) after the caller hangs up. The feature will not work once the called party hangs up.

Note: This feature must be allowed in network programming for your PRI lines from your service provider.

The following information registers on the network:

- called party number
- calling party number
- local time and date of the invocation in the network serving the called user
- service provider option: calling party subaddress, if provided by calling user)

MCDN services (profiles 1, 2, 4)

If your system is part of a private network using PRI SL-1 lines, you can determine the MCDN features that will be allowed by your system. These settings are described in detail in the networking section of this book. Refer to *MCDN trunk call features* on page 133.

- TRO: Trunk Route Optimization
- ICCL: ISDN Call Connection Limitation
- TAT: Trunk Anti-Tromboning

To program these features:

1. With the display showing **System Prgrming** press until the display shows **NetworkServices**.
2. Press . **ETSI** displays.
3. Press . **MCDN** displays.
4. Press . **NetwkICCL** displays.
5. Press **CHANGE** to choose either **Y** (yes) or **N** (no). Default is **No**.
6. Press . **TRO** displays.
7. Press **CHANGE** to choose either **Y** (yes) or **N** (no). Default is **No**.
8. Press . **TAT** displays.
9. Press **CHANGE** to choose either **Y** (yes) or **N** (no). Default is **No**.

Note: TRO and TAT cannot both be set to Y, as TAT will not work if TRO is active.

Note: If you set NetwkICCL to yes, check the Max transits settings under hardware to confirm the threshold at which you want the system to release the call rather than to continue cycling. Refer to “Max transits” on page 465.

Telco features

Currently the two features accessed under this heading are the settings for the voice mail connections for your system, and how to set up outgoing name and number blocking (ONN).

With the display showing **System Prgrming** press until the display shows **Telco features**.

VMsg ctr tel#s

If you subscribe to a voice message service outside of your local system, you can access it through your Norstar system. This includes centralized voice mail that is installed on another system within the private network that your system is connected to. Refer to *Central voice mail and Auto Attendant with Norstar* on page 146.

This setting specifies the external telephone numbers that are dialed by the Message feature to retrieve voice messages.

1. At the Telco Features prompt, press . **Vmsg ctr tel#** displays.
2. Press . **VMSG center 1** displays.
3. Press . **Use: Line** displays.
4. Press **CHANGE** to select either **Line** or **Routing tbl**.



Tip - *If you choose Routing tbl, you must ensure that this number contains the routing code, and that the number is entered in the routing table and routed to the correct line pool.*

5. Press . **Tel#: No number** displays.

6. Press **CHANGE** and enter the telephone number for the voice message system.
7. Press to move up a level.
8. Press to move to the next Voice message center.
9. Repeat steps 2 to 6 for however many voice message centers you want to enter.



Tips - *A telephone does not show that external voice messages are waiting unless Ext1 VMs9 set is set to Y (Yes). The setting is in CLASS assignment under Terminals&Sets.*

You can program up to five voice message center numbers, but most systems require only one.

Outgoing Name and Number Blocking

Outgoing Name and Number blocking blocks the outgoing name and number on a per call basis when the user presses

ONN blocking is cancelled with

When this feature is used, the call is flagged to the CO so that the name and number will not be presented to the person being called. Refer to *Outgoing Name and Number Blocking* on page 432 for more information.

1. At the Telco Features prompt, press . **ONN blocking** displays.

Programming the analog vertical service code (VSC)

1. Press . **Analog VSC** displays.
2. Press . **Tone:None** displays.
3. Press **CHANGE** to enter a new tone dialing Name and Number blocking VSC.

The VSC for tone trunks can include a maximum of 10 digits consisting of the CO Pause (), and digits 0-9, *, and #.

4. Press . **Pulse:None** displays.
5. Press **CHANGE** to enter a new pulse dialing Name and Number blocking VSC.

The VSC for pulse trunks can include a maximum of 10 digits consisting of the digits 0-9. Pulse trunks do not support , * or #. The * is represented by 11 (two consecutive ones).

Programming the BRI VSC

1. Press until **BRI VSC** displays.
2. Press . **Code:None** displays.
3. Press **CHANGE** and enter a new BRI name and number blocking VSC. This entry can be up to 10 digits, consisting of CO Pause (), digits 0-9, *, or #.

Setting up the modules for ONN blocking

To utilize ONN blocking, the CO is alerted by two methods, the Vertical Service Code (VSC) or suppression bit method. Each method depends on the type of trunk involved in placing the outgoing call.

Analog trunks use a dialing digit sequence called VSC. Most COs use the suppression bit method for ONN. You will need to use the VSC ONN if your CO does not support the suppression bit method. The VSC differs from region to region and must be programmed.

- Analog trunks with both tone and pulse dialing trunks can have separate VSCs.
- BRI trunks support one VSC.
- PRI trunks do not utilize the VSC.

The second method used to alert the CO is by a suppression bit packaged within the call setup message. BRI trunks can use either method.

Note: PRI trunks only support the suppression bit method of signalling the CO to block the outgoing Name and Number to the calling party, therefore, no additional programming is required.

When you program ONN blocking on a BRI module, you must indicate which method the BRI trunk will use. The module loop setting supports two ONN states. You must program the BRI loop to match the method supported by your service provider.

- If `SrvcCode` is programmed, then the VSC programmed under `Telco Features` is used.
- If `SuprsBit` is programmed, then the suppression bit will be packaged in the call setup message.

Program ONN blocking BRI loop state

The display shows the loops found on the BRI card.

1. Press to display the settings for individual loops on a BRI card.
2. At the **LOOPS** display, press next to display the first loop number.
3. Press . **Type:T** displays.
4. Press until **ONNblk:SuprsBit** displays.
5. Press **CHANGE** to toggle the BRI loop state setting from **SuperBit** to **SrvCode**.
6. Repeat steps 1 to 4 to program ONN blocking BRI loop state for other loops, as required.

ONN call blocking notes:

- Set, line and set/line restrictions have no effect on digits programmed within the ONN feature code.
- Call back from the CO is disallowed with this feature.

Software keys

Some of the MICS system features require special pass codes, called software keys, to make the feature work. This section describes each of these options. To obtain the required Software key, call the Integrated Voice Response (IVR) Center at: **1-800-4NORTEL (667835)**, then use Express Routing Code **1599**.

ISDN-PRI

A software key is required so that you can configure a DTI card as a PRI card.

MCDN

To create a private network using MCDN or tandem linking, you need a PRI key and a key specific to MCDN.

Companion (MICS-XC only)

Software keys are used to activate Companion components on systems running the MICS-XC 6.0 software. See the *Modular ICS Companion Installer Guide* for more information.

You will need to provide the following information:

- the System ID of the Norstar ICS
- the authorization number printed on the Bandwidth Allocation License Instruction Sheet
- the number of Directory numbers (DNs) configured in the system
- the number of lines configured in the system



Re-entering software keys.

Should the system be powered down for 72 hours or more, you will need to obtain and enter new software keys.

System Identification Number

Obtain the System ID (SysID) by pressing

, or

on any system set.

This information is also available by accessing **Software keys** in an Installer programming session:

1. Press The display reads **SysID:** followed by the unique System Identification Number.
2. Press to continue in **Software keys** or to exit.
3. Record the SysID in the Modular ICS *Programming Record*.

Call the Nortel Customer Response Center

1. Call the number given in the description of the software key you need.
2. Follow the voice prompts.
3. You will be given three separate numeric strings that contain eight digits each.
4. Record the Password keys in the Modular ICS *Programming Record*.

Entering the software keys

Keys are entered by accessing **Software keys** in a programming session.

1. Press . The display reads **SysID:**.
2. Press . The display reads **Password keys.**
3. Press . The display reads **Key 1:..**
4. Enter the eight-digit password number for Key 1.
Use **BKSP** to make corrections. The display reads **Key 2:..**
5. Enter the eight-digit password number for Key 2.
6. Proceed as above until you have finished entering Key 3.
The display reads **Entry successful.**
7. Press until the display reads **Software keys**
or press to exit.

Note: If the entry is unsuccessful, the display shows **Invalid Password**. If this happens, re-enter the code or call Nortel Customer Response Center at 1-800-4-NORTEL (667835) for assistance.

Hardware

Hardware is where you view and change settings for cartridges installed in the ICS, Trunk Modules, Station Modules, and Data Modules.

Show module

Installer password required

The Show module setting automatically displays the modules connected to the system. Press to select the setting: **KSU**, Mod 03, Mod 04, Mod 05, Mod 06, Mod 07, Mod 08.

Note: MICS-XC has 14 modules.

Cards on KSU

Installer password required

The Cards on KSU setting allows you to specify the type of Trunk Cartridges in the ICS.

Press to select the setting: **T1**, PRI, BRI-U4, BRI-U2, BRI-ST, E&M, DID, or Loop.

Note: KSU is also known as the Integrated Communication System (ICS).

- Loop is the default setting used for Loop Start and Call Information (CI) Trunk Cartridges.
- Select the T1 or PRI setting for DTIs cards.



Tips - *You cannot change this setting unless you first disable the Trunk Cartridge using **Module status in Maintenance**. Remember to enable the Trunk Cartridge once you have completed programming. See **Module status on page 495** for details. The Trunk Cartridge slots in the ICS are numbered from right to left.*

Once you specify the type of Trunk Cartridge in the ICS slot, press to display the range of line numbers for the lines on the Trunk Cartridge.

Provisioning the DTI card for PRI

The Cards on KSU setting allows you to specify the type of Trunk Cards in the ICS.

Note: Remember, you require a software password to activate PRI on your system.

Start with the display showing **Hardware**.

1. Press . The display shows **Show module**.
2. Press . The display shows **Cards on KSU**.
3. Press . The display shows **Cd1-KSU**:
4. Press **CHANGE** to view the different cards: T1, PRI, BRI-U4, BRI-U2, BRI-ST or **Loop**.
5. Select PRI. The display shows **Clear line data**.
6. Select **Y** (Yes) to confirm your selection.

For more information on provisioning cards see *Hardware* on page 455.

Selecting a protocol

Now that the DTI card has been provisioned as PRI (or is already part of the system) you can select a protocol.

With the display showing **PRI**

1. Press .
2. Press until the display shows **Protocol**:

3. Press **CHANGE** to select a different protocol from the table that follows:

Protocol	Type
NI-2, DMS100, DMS250, AT&T4ESS	Public
SL-1	Private Note: This will not display unless you have entered the MCDN software code.

If you selected the NI-2 protocol, and you are using call-by-call services, you must specify how Norstar should handle the NSF (Network Specific Facilities) information element as follows:

- Press .
- Press until the display shows **the default protocol NSF EXT: None**.
- Press **CHANGE** to select another setting based on your switch type, as shown in the following table:

Central Office	NSF Extension Setting
DMS100	None
Siemens ESWD, Lucent 5ESS	WATS
GTD5, DMS10	ALL

The Network Specific Facilities (NSF) information element is used to request a particular service from the network.

- When you select **NONE**, the NSF extension bit is not set for any service.
- When you select **WATS**, the NSF extension bit is set for unbanded **OUTWATS** calls.
- When you select **ALL**, the NSF extension is always set for all **CbC** services.

4. Press . If the display shows **Clear Routes**, press **Y** (yes) to confirm your selection.

BchanSeq

B-channel sequence allows you to select either **ascending** or **descending**. You need to choose the opposite setting of your service provider.

However, if all lines for two DTI cards (configured as PRI) are in the same PRI pool, then both cards must be set to use the descending B-channel sequence mode. As a result, the service provider must use ascending mode

Press **CHANGE** to select either **ascending** or **descending**.

Call-by-call routing

By default, incoming calls are routed based on the Called Party Number. You program the received number length to include however many digits your system requires. This many digits from the end of the called party number are then used as Received Digits to find a target line.

For example, the incoming calling party number is 800-555-1234. The received digit number length is 4. Therefore, 1234 is used to route the call.

Depending on the protocol and the service, alternate routing maps may be defined.

To change the incoming call routing for a service, with the display showing **Protocol:**, do the following:

1. Press until the display shows **CbC Routing**.
2. Press . The display shows **FX:**.
Press **NEXT** to display a different service.

Note: The display shows the first applicable service for the given protocol, in this example the service is **FX**.

3. Press **CHANGE** to change the mapping that is applied to incoming calls of this service type to obtain the received digits. In all cases, the received digits are used to find a target line or to activate Remote Access.

None — No mapping is applied. The received number length determines the number of digits of the Called Party Number which will be used as received digits.

Note: If there is no called party number, which may occur with some FX calls, the call will ring at the incoming trunk Prime set.

All — Allows you to define the received digits used for all calls with this service type, regardless of the called party number or service identifier (SID). For this option, all calls with this service type on this PRI will ring the same target line.

Map table — Allows you to associate different received digits with different calls of this service type, depending on the call party number and/or the service identifier. Incoming calls that do not match any entry defined in the map table will ring at the prime set. Depending on the service type and the protocol, you may be able to map the called party number and the service identifier.

The following table shows the different options.

Protocol	Service				
	FX	800	I-800	SDS	900
NI-2	SID	CDN	n/a	n/a	n/a
DMS-100	SID	SID or CDN	n/a	n/a	n/a
DMS-250	SID	SID or CDN	n/a	n/a	SID or CDN
4ESS	n/a	CDN	CDN	CDN	CDN

Discon timer

Disconnect timer allows you to specify the duration of an Open Switch Interval (OSI) before a call on a supervised external line is considered disconnected.

Press **CHANGE** to select the setting: **60**, **100**, **260**, **460**, or **600** milliseconds.



Tips - *Disconnect Supervision is assigned to each line with the Trunk mode setting. See Trunk/Line data on page 333.*

This setting must match the setting for the line at the central office (CO).

This setting only appears for DTI (T1) and Loop Trunk Cartridges.

Answer timer

Installer password required

Answer timer allows you to set the minimum duration of an answer signal before a call is considered to be answered.

Press **CHANGE** to select the setting: **1**, **2**, **3**, **4** or **5** seconds.

Note: This setting only appears for DTI (T1) and E&M Trunk Cartridges.

CO fail

Installer password required

Select the carrier failure standard used by your T1 or PRI service provider.

Press **CHANGE** to select the setting: **TIA-547A** or **TR62411**.



Tips - *This setting only appears for DTIs.*

Consult your T1 or PRI service provider for the proper setting.

I/F levels

Installer password required

Interface levels defaults to the ISDN loss plan setting.

Press **CHANGE** to select setting: **ISDN**, **PSTN** or **ISD/TT** interface levels.



Tips - Find out if your Norstar system is connected to a central office (CO) with digital network loss treatment (ISDN I/F levels) or analog network loss treatment (PSTN I/F levels) by checking with your telecommunications service provider.

The ISDN setting requires digital access lines (DAL) that have digital network loss treatment. On a DAL network, it is the PBX that administers the dB loss. DALs may have ISDN signaling or digital (such as T1 and so on) signaling. To have DAL network loss treatment on a line with digital signaling, you must contact your service provider.

The PSTN setting requires analog access lines (AAL) that have analog network loss treatment and digital signaling. On an AAL network, the CO administers the dB loss.



Tips - The ISD/TT setting is only for T1 and PRI interfaces (MCI services only). ISD/TT provides a loss level that is similar to DAL except for certain analog connections where the DB level increases by three.

Each loss plan uses a transmit objective loudness rating of -46 dB. The ISDN and ISD/TT loss plan uses a receive objective loudness rating (ROLR) of 51dB and the PSTN loss plan uses a ROLR of 48 dB.

Choosing the wrong setting may affect voice quality.

Framing

Installer password required

Framing allows you to select the framing format used by your T1 or PRI service provider.

Press **CHANGE** to select the setting: **ESF** (Extended Superframe) or **SF** (Superframe).



You must disable the Trunk Cartridge using Module status in Maintenance before you can change this setting. See Module status on page 495 for details.



Tips - *This setting only appears for DTIs. Consult your T1 or PRI service provider for the proper setting.*

SF or Superframe is sometimes known as D4.

Internal CSU

Installer password required

Internal CSU allows you to turn the internal T1 channel service unit on or off. The channel service unit gathers performance statistics for your T1 lines or PRI with public interface.

Press **CHANGE** to select the setting: **On** or **Off**.



You must disable the Trunk Cartridge using Module status in Maintenance before you can change this setting. See Module status on page 495 for details.



Tips - *This setting only appears for DTIs. Consult your service provider for the proper settings.*

*You can view the performance statistics for your T1 lines in Maintenance under the **CSU stats** heading.*

If you use an external CSU with your T1 lines, then set the internal CSU to off.

CSU line bld

Installer password required

CSU line build allows you to set the gain level of the transmitted signal.

Press **CHANGE** to select the setting: **0**, 7.5 or 15 dB.



You must disable the Trunk Cartridge using Module status in Maintenance before you can change this setting. See Module status on page 495 for details.



Tips - *This setting only appears for DTIs that have the internal CSU turned on.*

Line coding

Installer password required

Select the standard used by your T1 service provider for encoding signals on the T1 lines. Press **CHANGE** to select the setting: **B8ZS** or **AMI**.



You must disable the Trunk Cartridge using **Module status** in Maintenance before you can change this setting. See *Module status* on page 495 for details.



Tips - *This setting only appears for DTIs.*

Consult your T1 service provider for the proper setting.



Enable Trunk Cartridges

If you disable any Trunk Cartridges to perform programming, enable them now using **Module status** in **Maintenance** or your system will not function properly. See *Module status on page 495* for information on enabling Trunk Cartridges in Module status.

ClockSrc

Installer password required

Clock Source allows you to designate which of the system Digital Trunk Interfaces (DTIs) obtains the timing reference from the network, which the system synchronizes to. For more on Clock Source settings, see page 476.

Max transits

Installer password required

If you allow ISDN Call Connection Limitation (ICCL) on your MCDN PRI system, you need to determine a threshold at which the system will release the call, rather than allow continued line tie ups. This threshold is called Max(imum) transits. The default value for this feature is 31.

Modules

The **Mod** setting allows you to specify the type of module you wish to configure.



Tip - *MICS-XC can have up to 14 modules.
Other MICS configurations have up to 8.*

Press **CHANGE** to select the setting: **StnMod**, **ASM**, **TrunkMod** or **DataMod**.

Note: ASM is the same as AEM, which is the analog station module.

StnMod

If a Station Module is selected and connected to the Modular ICS, no extra programming is required. Each Station Module represents 16 new DN's. For more information on lines and DN's used by the Station Module, see *Wiring charts* on page 241.

ASM

If an Analog Station Module is selected and connected to the Modular ICS, no extra programming is required.

The module defaults to:

- two extension lines are assigned
- Full Handsfree is disabled
- Handsfree is enabled
- all exchange lines are assigned to Ring
- Answer Keys cannot be assigned to the AEM
- allow Redirect

To verify the status of the module:

1. Navigate to **Maintenance and Module Status**.
Show module: displays.
2. Enter the module number you want to verify.
8 extns on EM displays.
3. Press **STATE**.
"x" sets busy displays

To verify the status of each port:

1. Navigate to **Maintenance** and **Port/Extn stat.**

Show Port.: displays.

2. Enter the port number you want to verify.

The display shows the port number.

TrunkMod

TrunkMod setting allows you to configure the Trunk Cartridges in the Trunk Module.

Press **CHANGE** to select the setting: **Loop**, **E&M**, **DID**, **BRI-ST**, **BRI-U2**, **BRI-U4** or **PRI**.

Loop is the default setting used for Loop start and Call Information (CI) Trunk Cartridges.



Tips - *You cannot change this setting unless you first disable the Trunk Cartridge using **Module status** in **Maintenance**. Remember to enable the Trunk Cartridge once you have completed programming. See **Module status** on page 495 for details.*

The Trunk Cartridge slots in the Module are numbered from left to right. Trunk Modules are numbered 3 to 4 for a midi, 3 to 8 for a maxi and a mega system.

Depending on your system configuration, off-core DTI, PRI, BRI-ST, BRI-U2, and BRI-U4 cards can only reside in certain trunk modules. In a midi system, the cards must be in trunk modules 3 or 4. In a maxi or mega system, the cards must be in trunk modules 7 or 8. The cards can reside in the ICS regardless of system size.

Once you specify the type of Trunk Cartridge in the ICS slot, press **SHOW** to display the line number range for the lines on the Trunk Cartridge.

Midi line number chart

Line numbers								
Midi	Loop	ST	U-2	U-4 (prfl 1)	DTI (PRI SL1- N12)	DTI (T1) (prfl 1)	E&M	DID (prfl1)
Cd1 ICS Mod 2	1-4	1-8	1-4	1-8	1-23 (prfl 1) 1-30 (prfl 2)	1-24	NA	NA
Cd2 ICS Mod 2	31-34	31-38	31-34	31-38	31-53 (prfl 1) 31-60 (prfl 2)	31-54	NA	NA
Cd1 Mod 04	61-64	61-68	61-64	61-68	61-83 (prfl 1)	61-84	61-64	61-64
Cd2 Mod 04	69-72	69-76	69-72	69-76	NA	NA	69-72	69-72
Cd3 Mod 04	77-80	77-84	77-80	77-84	NA	NA	77-80	77-80
Cd1 Mod 03	85-88	85-92	85-88	85-92	85-107 (prfl 1)	85-108 (prfl 1)	85-88	85-88
Cd2 Mod 03	93-96	93- 100	93-96	93-100	NA	NA	93-96	93-96
Cd3 Mod 03	101- 104	101- 108	101- 104	101- 108	NA	NA	101- 104	101- 104

Target lines: 157-284

Note: Off-core DTI uses line numbers for all three card positions in whichever module (3 or 4) it is installed in.

Maxi/Mega line number chart

Line numbers								
Maxi/ Mega	Loop	ST	U-2	U-4 (prfl 1)	DTI (PRI SL1-N12)	DTI (T1) (prfl 1)	E&M	DID
Cd1 ICS Mod 2	1-4	1-8	1-4	1-8	1-23 (prfl 1) 1-30 (prfl 2)	1-24	NA	NA
Cd2 ICS Mod 2	31-34	31-38	31-34	31-38	31-53 (prfl 1) 31-60 (prfl 2)	31-54	NA	NA
Cd1 Mod 08	61-64	61-68	61-64	61-68	61-83 (prfl 1)	61-84	61-64	61-64 (prfl 1)
Cd2 Mod 08	69-72	69-76	69-72	69-76	NA	NA	69-72	69-72 (prfl 1)
Cd3 Mod 08	77-80	77-84	77-80	77-84	NA	NA	77-80	77-80 (prfl 1)
Cd1 Mod 07	85-88	85-92	85-88	85-92	85-107 (prfl 1)	85-108 (prfl 1)	85-88	85-88 (prfl 1)
Cd2 Mod 07	93-96	93- 100	93-96	93-100	NA	NA	93-96	93-96 (prfl 1)
Cd3 Mod 07	101- 104	101- 108	101- 104	101- 108	NA	NA	101- 104	101- 104 (prfl 1)
Cd1 Mod 06	109- 112	NA	NA	NA	NA	NA	109- 112	109- 112
Cd2 Mod 06	113- 116	NA	NA	NA	NA	NA	113- 116	113- 116
Cd3 Mod 06	117- 120	NA	NA	NA	NA	NA	117- 120	117- 120
Cd1 Mod 05	121- 124	NA	NA	NA	NA	NA	121- 124	121- 124
Cd2 Mod 05	125- 128	NA	NA	NA	NA	NA	125- 128	125- 128

Maxi/Mega line number chart (Continued)

Line numbers								
Maxi/ Mega	Loop	ST	U-2	U-4 (prfl 1)	DTI (PRI SL1-N12)	DTI (T1) (prfl 1)	E&M	DID
Cd3 Mod 05	129- 132	NA	NA	NA	NA	NA	129- 132	129- 132
Cd1 Mod 04	133- 136	NA	NA	NA	NA	NA	133- 136	133- 136
Cd2 Mod 04	137- 140	NA	NA	NA	NA	NA	137- 140	137- 140
Cd3 Mod 04	141- 144	NA	NA	NA	NA	NA	141- 144	141- 144
Cd1 Mod 03	145- 148	NA	NA	NA	NA	NA	145- 148	145- 148
Cd2 Mod 03	149- 152	NA	NA	NA	NA	NA	149- 152	149- 152
Cd3 Mod 03	153- 156	NA	NA	NA	NA	NA	153- 156	153- 156

Target lines: 157-284 (expanded: 157-348)

Note: Off-core DTI uses line numbers for all three card positions in whichever module (7 or 8) it is installed in.

BRI card

Loop

Installer password required

The display shows the loops found on the BRI card.

Press to display the settings for individual loops on a BRI card.

Type

Press CHANGE to select the loop type.

- If the card type is BRI-ST, the loop type can be S, or T.
- If the card type is BRI-U2 or BRI-U4, the loop type can be LT or NT.



The BRI card must be disabled in `Module status` before this setting can be changed. You can change the setting if the card has not yet been installed in the ICS slot.

Lines

There are two lines for each T or NT loop.

Loop	Default lines
201	001-002
202	003-004
203	005-006
204	007-008
231	031-032
232	033-034
233	035-036
234	037-038

No SPIDs assigned

Installer password required

T and NT loops can be assigned a system profile identifier (SPID) as supplied by your service provider. No SPIDs are assigned by default.

When the loop type is T, calls on the loop are handled for a network connection only. If any other ISDN equipment is connected to the loop, it must be configured as an S loop to ensure proper call handling.

1. Press **ADD** and enter the first or second SPID assigned to the loop.
If there are two SPIDs already assigned to the loop, **ADD** will not appear until one is removed.
2. Press **REMOVE** to clear a SPID.

Note: Profile 2 loops do not require SPIDs.

of B-channels

Installer password required

Press **CHANGE** to select the number of B-channels that are associated with the SPID: **1** or **2**.



Tips - *When you order an ISDN capability package that supplies two B-channels, you may receive one or two SPIDs from your service provider.*

- *If you receive one, it usually means you will configure the SPID to use two B-channels.*
- *If you receive two, it usually means you will configure each SPID with one B-channel. Check with your service provider if you are not sure about the proper configuration.*

Network DNs

Installer password required

1. Press to display the DNs which are used with the SPID.
2. Press **ADD** and enter the appropriate number to assign additional Network DNs to the SPID.

The Modular ICS can have a maximum of 128 Network DNs for the system. There is no limit to the number of Network DNs for each SPID, but you cannot exceed the limit of 128 Network DNs for the system.

If the Network DN you try to enter is already assigned to a SPID with a call type of Both, you will not be able to assign the DN again.

If the Network DN you enter is already assigned to a SPID and the call type is Voice or Data, it will be automatically programmed with the unused call type. For example, if the DN has Call type set to Voice in the previous SPID assignment, it will be automatically set to handle Data calls when the same DN is added to the other SPID.

Call type

Installer password required

Press **CHANGE** to select the call type of the Network DN:
Voice, Data, or Both.

CHANGE will not appear if the Network DN is already in use by the system and the call type will be automatically programmed with the unused call type. For example, if the DN has Call type set to Voice in a previous SPID assignment, it will be automatically set to handle Data calls when the DN is entered the second time.



Tips - *If our service provider does not specify the call type for each Network DN, it is probably available for both voice and data. Check with your service provider if you are not certain about the proper configuration.*

D-packet service

Installer password required

1. Press to view and program D-packet service for T or NT loops. You can have two D-packet service configurations for each BRI card.
2. Press CHANGE to turn D-packet service for this loop on (Y) or off (N).



Tips - *An LT loop must already be assigned.*

Lp

Installer password required

1. Select the S loop (for BRI-S/T cards) or LT loop for BRI-U2 or BRI-U4 cards that supports the D-packet service.
2. Press CHANGE to move through a list of the loops which are available on this card.

Note: If only one loop is available, you will not see CHANGE.

TEIs

Installer password required

Press to view and program the Terminal Endpoint Identifiers (TEIs). Each TEI is supplied by your service provider and is associated with an ISDN D-channel packet device.

No TEIs on loop

Installer password required

Press **ADD** to program up to eight TEIs to this loop.

Sampling

Installer password required

Press **CHANGE** to select the sampling used by an S loop:

- **Fixed** — if two or more S-interface devices use the loop and the length of the loop is less than 200 m (650 ft.), select Fixed.
- **Adaptive** — if two or more S-interface devices use the loop and the length of the loop is greater than 200 m (650 ft.), select Adaptive.

If one S-interface device is using the loop, the length of the loop can be up to 1000 m (3,250 ft.) and the rate should be set to **Adaptive**.

The BRI card must be disabled under **Module status** in Maintenance programming, before you can change this setting. You can change the setting if the card has not yet been installed in the ICS slot.

DNs on Loop

Installer password required

Press to view and program the ISDN DN's assigned to the loop.

Assign DNs

Installer password required

1. Press and enter the ISDN DN you wish to assign to this loop, or press **SCAN** to move through a list of DNs already assigned to the loop.

The display shows:

- **Availabl, Assigned** — assigned to this loop
 - ***Lnnnn*** — assigned as the default DN of another loop
 - **Lnnnn** — assigned to another loop
2. Press **LIST** to view the DNs assigned as ISDN DNs.
The default ISDN DN range is 667-696. For information about changing ISDN DN type, see *Changing Companion DN type* on page 425.
 3. Press **CHANGE** to assign the DN to the loop or to remove it.

Loop DN

Press **CHANGE** to move through the ISDN DNs you have assigned to the loop.

This will assign the main ISDN DN to the loop.
You can also set Loop DN to **None**.

Clock Src

Installer password required

Systems with digital interfaces need to synchronize to the network in order to function. Synchronization is done in a hierarchical way, where each device/switch obtains the network clock from the device/or switch above it in the synchronization hierarchy and passes the network clock to the device/switch below it in the synchronization hierarchy. The synchronization levels are referred to as strata.

Norstar systems are stratum 4E equipment and are usually used as termination points in a network.

For each DTI, choose one of the following settings:

Primary reference

The DTI obtains the timing reference from the network, which the system synchronizes to. This is the default value for the DTI in slot 1 in the ICS. If the system is configured with a DTI card that has been configured as PRI, the setting should be set to Primary.

Secondary reference (Secndry)

The DTI acts as a standby reference. If there are excessive errors on the primary reference T1 link, or the DTI designated as primary reference fails, this DTI will obtain the timing reference from the network, which the system synchronizes to. This is the default value for the DTI in slot 2 in the ICS.

Timing master (TimeMstr)

The DTI does not obtain timing from the network, but transmits the systems timing to equipment connected to it.



Tips - *If a BRI card becomes clock source, it will have up to four clock sources available (T, S, U-NT, NT loops only). Only when all four clock sources have an alarm will the card cause a switch to the secondary or hold-over state.*

BRI -T, S, and U-NT interface loops may be autonomously powered down by the network. This will be treated as a loss of clock source on that loop.

The installer should ensure that clock source loops are either not powered down or are among the last to be powered down.

If BRI cards are used only for S-loops, a Service Card is required only if the DTI is T1. However, a Services Card is recommended when a T1 is not used, since the card improves clock accuracy and performance.

If BRI cards are used off-core, they still require a connection to the network, which requires the SC, and an on-core digital clock source.

For more information on network synchronization, consult the appropriate private digital network synchronization standards.

The following illustrations show some typical network configuration and the appropriate clock source settings for your DTIs.

Norstar connected directly to the service provider in a T1 network

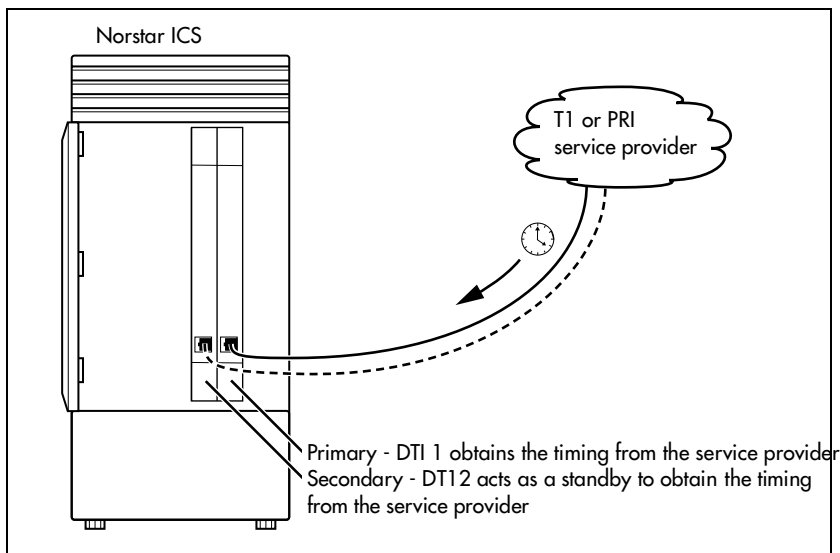

Norstar connected to another switch or MUX in a T1 or PRI network

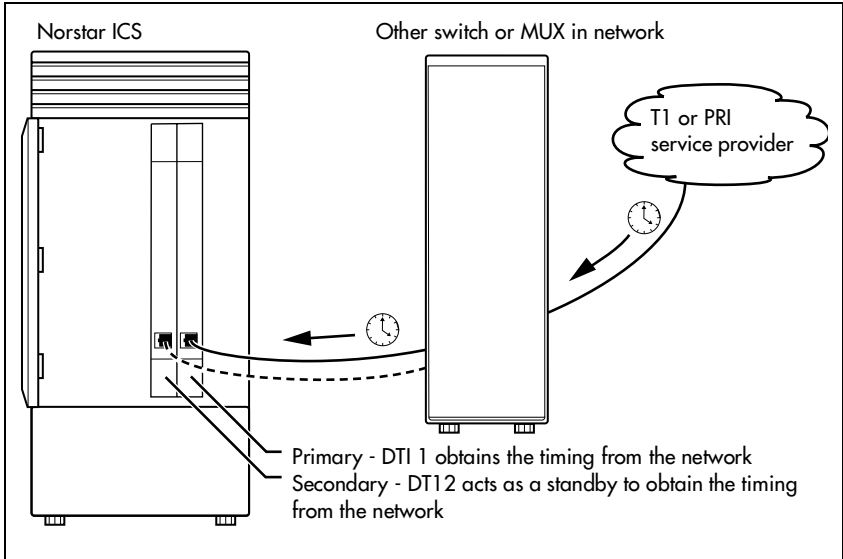

Norstar connected to another switch in a closed T1 or PRI network

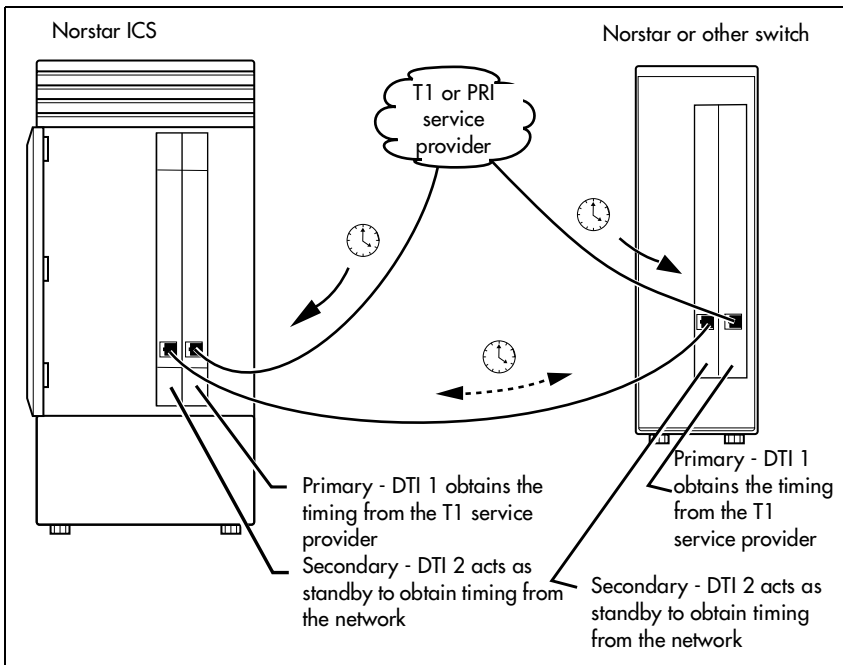

Norstar connected in a series of switches in a T1 or PRI network

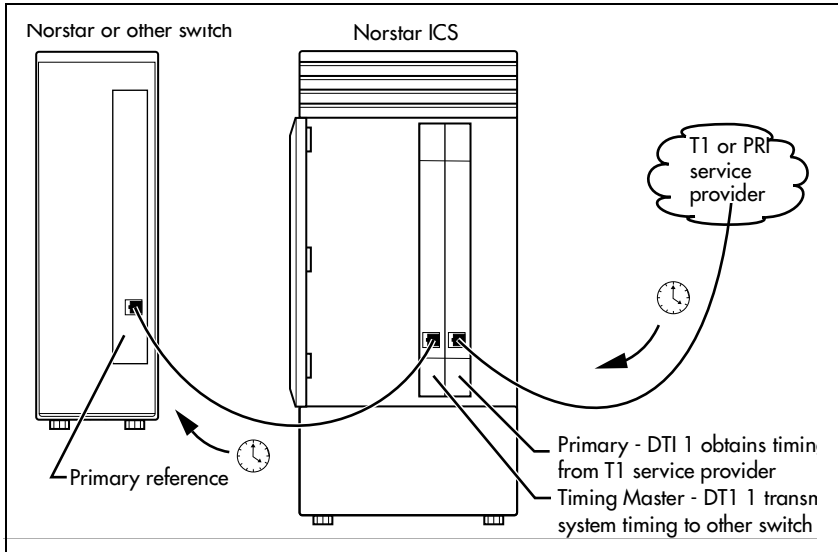

Norstar connected by a T1 link to another switch in an analog network

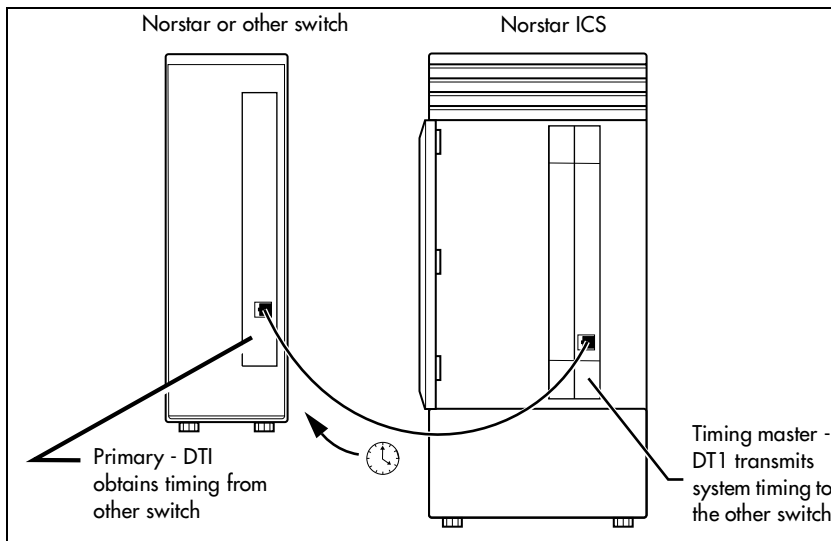

Setting the clock source for DTIs and PRI installer password required***Changing clock source may disconnect calls.***

Changing the clock source for your system may cause your system to restart itself, resulting in dropped calls. Choose a suitable time to change the clock source and use the Page feature to inform people of possible service disruptions.

Start with the display showing **Hardware**.

1. Press .
2. Press . The display shows **Cards on KSU**.
3. Press .
4. Press until the display shows the card you want to view.
5. Press .
6. Press until the display shows **ClockSrc**.
7. Press **CHANGE** to toggle the setting.

8. Press  to exit or to continue in **Hardware**.



Tips - *In most T1 network configurations, you need one DTI or DTI card configured as PRI in your ICS to act as a primary reference. The only application where you might not have a DTI or a DTI card configured as PRI designated as primary reference is in a network where your Norstar system is connected back-to-back with another switch using a T1 link. If the other switch is loop-timed to your Norstar system, your DTI or DTI card configured as PRI can be designated as a timing master.*

If your Norstar system has two DTIs, you cannot assign both DTIs as primary reference or both DTIs as secondary reference.

You can only have one primary reference and one secondary reference per system. See T1 or ISDN-PRI configurations for more information.

T1 or ISDN-PRI configurations

The following tables indicate proper and improper T1 or ISDN-PRI configurations:

Valid digital trunk configurations

	Option 1	Option 2	Option 3
Card 1	T1 or PRI	T1 or PRI	BRI-ST, BRI-U2, BRI-U4
Secondary Card 2	T1 or PRI	BRI-ST, BRI-U2, BRI-U4	BRI-ST, BRI-U2, BRI-U4

Invalid digital trunk configuration

Option 1	
Primary Card 1	BRI-ST, BRI-U2, BRI-U4

Option 1	
Secondary Card 2	T1 or PRI

Valid mixed trunking configuration

	Option 1	Option 2
Primary Card 1	T1 or PRI	BRI-ST, BRI-U2, BRI-U4
Card 2	Analog	Analog

Invalid mixed trunking configuration

	Option 1	Option 2
Card 1	Analog	Analog
Secondary Card 2	T1 or PRI	BRI-ST, BRI-U2, BRI-U4

Invalid configurations will raise an alarm. In these invalid configurations, digital links are likely to suffer errors, slips, etc.

DataMod

Mod XX:DataMod

DataMod allows you to configure the settings for any data modules you may have on your system.

Type

The display shows the type of data module selected.

Maintenance

Use Norstar Maintenance to help you understand and diagnose system problems that occur on your Norstar system.

Maintenance includes settings to determine how the system will deal with T1 digital lines. It also provides a means for provisioning and testing digital lines.

The Maintenance section of programming has these headings.

<code>System version</code>	displays the version number of the system processor
<code>Port/DN status</code>	allows you to check and change the status of ports in your system
<code>Module status</code>	allows you to check and change the status of modules in your system
<code>Sys test log</code>	displays a list of test results, event messages, and alarm codes
<code>Sys admin log</code>	displays a list of system initialization sessions, invalid password attempts and password changes
<code>Network evt log</code>	displays a list of events and alarms
<code>Provisioning</code>	allows you to add or remove individual T1 lines, PRI lines, and BRI loops in and out of service
<code>Tests</code>	allow you to test incoming T1 signals to evaluate transmission quality, the connection between the ICS and telephones, and the connection between a DTI (configured as PRI) or BRI Card and the network
<code>CSU stats</code>	displays T1 performance information supplied by the Channel Service Unit
<code>Link status</code>	allows you to view status of b-channels on PRI

You can run a Maintenance session from any working M7310, M7324 or T7316 set.



Tip - *Only one person at a time can access a Maintenance session.*

Photocopy the Maintenance records found in the *Programming Record*, and record the information the session provides.

Beginning a Maintenance session

1. Release all calls on your telephone.
2. Press which is the same as . **Password:** displays.
3. Enter the Installer password. **Terminals&Sets** displays. Three triangular indicators ► appear on the vertical display between the rows of buttons.
4. Place the programming overlay over the buttons pointed to by the indicators ►.
5. Press until the display shows **Maintenance**.

System version

System version allows you to note the version number of the System Processor (SP) software, which resides in the Feature Cartridge.

Use the SP version number to determine whether you have the latest software release, and to trace a software fault if one occurs.

For instance:

- SP version number can indicate a Feature Cartridge incompatibility.
- SP and telephone version numbers can indicate a telephone version incompatibility.
- SP and functional terminal version numbers can indicate a functional terminal incompatibility.

Checking the version of the system

To check the version number, start with the display showing **Maintenance**.

1. Press . **System version** displays.
2. Press .

The display shows the version number of the SP.

3. Write the SP version number on the appropriate Maintenance record.
4. Press . **System version** displays.

Port/DN status

Port/DN status allows you to:

- identify any device or line connected to the system
- check the version number of a device for compatibility with the system, for instance for an analog terminal adapter (ATA).
- check the state of a device or line, for example, idle or busy
- disable or enable a device
- determine which port number corresponds to each DN
- determine the port number of a malfunctioning device
- determine if a malfunctioning device is incompatible with the Norstar system
- disable a device before replacing it



Tips - *You cannot disable the telephone from which you are accessing the Maintenance session. If you try to do this, a message appears on the display and you hear an error tone. If you want to disable that particular telephone, conduct the Maintenance session from another telephone.*



Pick a suitable time to disable devices

Wait until after regular user hours to disable devices to cause the least disruption to your customers.

Do **not** enable or disable ports at the following times:

- during the first two minutes after Startup programming
- before fiber cables are connected

If you do so, incorrect ports may be enabled or disabled. To recover from this, disable, then enable, the affected modules using `Module status`.

`Port/DN status` allows you to check lines and devices on the system. Although the following procedures describe how to check devices, you can use the same procedures to check lines.

Lines can only be disabled in `Module status`.

Identifying a connected device

Installer password required

Start with the display showing `System version`.

1. Press . `Port/DN status` displays
2. Press . `Show Port:` displays
3. Enter the port number of the device, or press `DN`, then enter the directory number of the device. The display shows device information, as illustrated in the following sample device identification display. This identifies the device connected to the B1 channel.
4. If there is an add-on device attached to a Norstar telephone, such as a central answering position module or a Busy Lamp Field, press to display the add-on device.
5. Press `>B2` to display the device connected to the B2 channel.
6. Press until the display shows `Port/DN status`.

Displays

Sample device identification display

```
P104 7324 224
DEVICE >B2 STATE
```

This sample display indicates that port 104 has an M7324 telephone whose DN is 224. Press DEVICE to see the device attached to the port.

The following table lists some of the device types that may appear on the Norstar device identification display.

Explanation of device type

Display	Explanation
7100	M7100 or T7100 set
7208	M7208 or T7208 set
7310	M7310 telephone or T7316 or T7406 Business Series Terminal telephones
7324	M7324 telephone
RAD	Remote access device
1: CAP1	First CAP module attached to an M7324 telephone
2: CAP2	Second CAP module attached to an M7324 telephone
ATA	Analog Terminal Adapter or Analog Station Module
BLF	Busy Lamp Field

Checking the device version number Installer password required

From the Norstar device identification display:

1. Press VERS# (if it is available).

The display shows the version number of the device.

2. Write this number on the appropriate Maintenance record.

To return to the Norstar device identification display from the display showing the version number, do one of the following:

- Press OK to retain the same port number. Press HEADING.

Press to see information about the next port number (or DN if that is how you entered).

OR

- Press to see information about the previous port number (or DN if that is how you entered).

Checking the state of the device Installer password required

From the Norstar device identification display.

1. Press STATE.

The display shows one of the states listed in the table that follows. If you want, you can disable or enable the device. Refer to *Disabling a device* on page 492 or *Examples of display messages* on page 493.

2. Press OK to return to the device identification display.

How the device state is shown on the display

Display	State of device
Busy DISABLE OK	The device is in use.
Disabling... OK	The device is being disabled.
Enabling... OK	The device is being enabled.
Idle DISABLE OK	The device is not in use.
Unequipped DISABLE OK	There is no device connected to that port.
Disabled by user ENABLE OK	The device has been disabled by someone running a Maintenance session.
Disabled by sys. ENABLE OK	The device has been disabled by the system because it is faulty or because a test is running.
Not available DISABLE OK	There is no state available.

Disabling a device

Installer password required



Give notice that you are disabling equipment.

Inform your users well in advance that you are going to disable their devices.

To disable immediately when the display indicates the device is busy:

1. Press DISABLE. `Disable at once? displays.`
2. Press YES.

The system prompts the device user and disables the device in one minute (or immediately, if the device is idle). Press NO to leave this display without disabling the device.

Displays

The following table shows examples of the sequence of messages that might appear on a telephone when you disable a device.

Examples of display messages

Please hang up Maintenance test	Occurs on a busy telephone before disabling
48 seconds until disconnect	
Please hang up	
In Maintenance	Occurs after disabling

Enabling the device

Installer password required

When the display shows you that the device is disabled:

Press ENABLE. **Enabling...** briefly displays.

The device is immediately enabled and the display shows **Idle**.



Tips - *The display may briefly show **Enabling...**, then either **Disabled by sys.** or **Disabled by user**. In this case, the system is waiting to enable the module. This may occur after someone has run a Maintenance session and used **Module status**. You cannot enable the device until its module has been enabled.*

*Individual lines cannot be disabled in **Port/DN status**. To disable a Trunk Cartridge, see **Module status** on page 495.*

Returning to the beginning

Installer password required

From the display showing the state of the device:

1. Press **OK**.
2. Press until the you reach **Port/DN status**.

Module status

Module status allows you to:

- look at the inventory of Station Modules, Trunk Modules, Data modules, and modules inside the Integrated Communication System (ICS)
- check the number of Trunk Cartridges in a module
- check the state of the module or its cartridges
- disable or enable the module or its cartridges
- isolate any malfunctioning modules
- disable a module before replacing it
- clear a hung line by disabling and enabling the affected Trunk Cartridge



Tips - *Modules 1 and 2 are located inside the ICS.*

Module 1 connects telephones.

Module 2 connects Trunk Cartridges.

Looking at the module inventory

Installer password required

Start with the display showing **Port/DN status**.

1. Press . The display shows **Module status**.
2. Press . The display shows **Show module:**.
3. Enter the module number.



Tips - *Norstar devices may occupy both the B1 and B2 channels. This may increase the number of devices indicated on the module inventory display. The display is different for Analog Station Modules (ASM) where it will show either 8 sets on ASM or 16 sets on ASM.*

Checking the number of Cartridges Installer password required

Start from the module inventory display, which shows the number of Trunk Cartridges connected to the module you chose, for example, **Mod 04: 3 cards.**

1. Press CARD.

If there is a Trunk Cartridge in a slot, the display shows that four lines are connected, for example,
Card 1: 4 lines.

2. Press or to check for Trunk Cartridges in the other slots.
3. Press MODULE to return to the module inventory display.

Checking the state of a module Installer password required

Start from the module inventory display, which shows the number of Trunk Cartridges connected to the module you chose, for example, **Mod 04: 3 cards.**

1. Press STATE.

The state of the module is shown on the display.

2. Press OK to return to the module inventory display.

Module or cartridge state is shown on the display

Example display	State of module or cartridge
3 sets busy DISABLE OK	There are three devices in use that are connected to the module or cartridge.
2 ports busy DISABLE OK	There are two ports in use that are connected to the module or cartridge.
4 lines busy DISABLE OK	There are four lines in use that are connected to the module or cartridge.

Module or cartridge state is shown on the display (Continued)

Example display	State of module or cartridge
Disabling... OK	The module or cartridge is being disabled.
Enabling... OK	The module or cartridge is being enabled.
Unequipped DISABLE OK	There is no module or cartridge connected to that DS-30 port.
Disabled by user ENABLE OK	The module or cartridge has been disabled from a Maintenance session.
Disabled by sys. ENABLE OK	The module or cartridge has been disabled by the system because it is faulty or because there is a test running.
Updating state..	The system is verifying the state of the module or cartridge.

Checking the state of a cartridge

Installer password required

Start from the display that shows the number of lines connected to the Trunk Cartridge you chose, for example, **Card 1: 4 lines.**

1. Press **STATE**.

The display shows the state of the cartridge. Some examples of this display are shown in the previous table.

2. Press or to check the Trunk Cartridges connected to the other Trunk Modules.
3. If required, you can disable or enable the cartridge. Refer to *Disabling a module or its cartridges* on page 498 or *Enabling a module or its cartridge* on page 498.
4. Press **OK** to return to the display showing how many lines are connected to the Trunk Cartridge.

Disabling a module or its cartridges Installer password required



Use Page feature prior to disabling.

Use the Page feature to inform people that you are about to disable a module. Mention that they may experience delays in the performance of their devices.

From the display showing the state of the module or cartridge:

1. Press DISABLE. `Disable at once? displays.`
2. Press YES.

The system disables the module or cartridge in one minute. If the status is idle, the system disables the module or cartridge immediately.

Press NO to leave this display without disabling the module or cartridge.

Enabling a module or its cartridge Installer password required

From the display showing the state of the module or cartridge:

1. Press ENABLE.

The display briefly shows `Enabling...`

The module or cartridge is immediately enabled.

The display then shows the state of the module or cartridge.

Returning to the beginning Installer password required

From any display showing the state of the module or cartridge:

1. Press OK.
2. Press until the display shows `Module status`.

System test log

The System test log shows you a list of diagnostic test results, audits, event messages, and alarm codes. By using this feature you can:

- check the items in the log
- check the current alarm (if there is one)
- check when each item in the log occurred
- check the number of consecutive occurrences of an event or an alarm
- erase the log

The System test log holds a maximum of 20 items. You should check and record these items at regular intervals. Erase the log after dealing with all the items.

Checking the items in the log

Installer password required

Start with the display showing **Module status**:

1. Press . The display shows **Sys test log**.
2. Press . The display shows **Items in log**:
(If there is no log entry, the display shows **Items in log:0** and returns to **Sys test log**.)
3. Press or . The display shows a log item.
4. Write down the item on the System test log record.
5. If the log item is an event message or an alarm code, refer to *Alarm codes* on page 506 or *Event messages* on page 514.
6. Repeat steps 3, 4, and 5 until you have recorded all the items.

Checking the current alarm

Installer password required

If you want to quickly check the highest severity alarm before viewing all the log items, start with the display showing **Items in log**:

1. Press **ALARM**.

The display shows an alarm code if there is a current alarm. If there is no current alarm, **ALARM** does not appear on the display.

2. Press **OK** to return to **Items in log**.

All alarms are recorded as items in the System test log.

Checking when each item occurred

Installer password required

Start with any display showing a log item:

1. Press **TIME**. The display briefly shows the date and time.
2. Write the date and time on the System test log record.

Checking consecutive repetitions of an event or alarm

Installer password required

If **REPEAT** appears under a display showing a log item:

1. Press **REPEAT**.

The display shows the number of consecutive times the event or alarm occurred.

Erasing the log

Installer password required

Start with the display showing **Items in log:**.

1. Press **ERASE**. **Erase log?** displays.
2. Press **YES**.

If no new items have been added since the list was entered, the log is erased and the display shows **Log erased**.

If new items have been added since the list was entered, the display briefly reads **Cancel-new items** and returns to the display **Items in log:**.

3. Press to return to **Sys test log**.

System administration log

The System administration log keeps a record of administrative events such as sessions in which a change was made, invalid password attempts, and password changes.

You can use this feature to:

- check the items in the log
- erase the log
- check when each item in the log occurred

The System administration log holds a maximum of 10 items. Erase the log after dealing with all the items.

Checking the items in the log

Start with the display showing `Sys test log`:

1. Press . The display shows `Sys admin log`.
2. Press . The display reads `Items in log:`. (If there is no log entry, the display reads `Items in log:0`.)
3. Press or . The display shows a log item.
4. Write down the item on the System administration log record.
5. Repeat steps 3 and 4 until you have recorded all the items.

Checking the current alarm

Start with the display showing **Items in log:**.

1. Press **ALARM**. The display shows an alarm code.

If there is no current alarm, **ALARM** does not appear on the display.

2. Press **OK** to return to the display showing **Items in log:**.

Checking when each item in the log occurred

Start with any display showing a log item:

1. Press **TIME**. The display shows the date and time.
2. Write the date and time on the System administration log record.

Erasing the log

Start with the display showing **Items in log:**.

1. Press **ERASE**. The display shows **Erase log?**.
2. Press **YES**.

If no new items have been added since the list was entered, the display shows **Log erased**.

If new items have been added since the list was entered, the display briefly reads **Cancel-new items** and returns to the display **Items in log:**.

3. If the display shows **Log has changed**, press **SHOW** to show the new log, or press **EXIT** to return to **Sys admin log**.

Network evt log

The Network evt log keeps a record of events and alarms that are specific to the T1 network interface.

You can:

- check the items in the log
- erase the log
- check when each item in the log occurred

The Network evt log holds a maximum of 20 items. Erase the log after dealing with all the items.

Checking the items in the log

Start with `Sys admin log` on the display:

1. Press . `Network evt log` displays.
2. Press . `Items in log:` displays.
If there is no log entry, the display reads `Items in log:0`.
3. Press or . The display shows a log item.
4. Write down the item on the Network event log record.
5. Repeat steps 3 and 4 until you have recorded all the items.

Checking the current alarm

Start with the `Items in log:` on the display.

1. Press ALARM.
The display shows an alarm code if there is a current alarm.
2. Press OK to return to `Items in log:`.

Erasing the log

Start with **Items in log:** on the display.

1. Press **ERASE**.

The display shows **Erase log?**.

2. Press **YES**.

If no new items have been added since the list was entered, the display shows **Log erased**.

If new items have been added since the list was entered, the display briefly reads **Cancel-new items** and returns to the display **Items in log:**.

3. Press to return to **Network evt log**.

Checking when each item in the log occurred

Start with any display showing a log item:

1. Press **TIME**.

The display shows the date and time.

2. Write down the date and time on the Network event log record.

Alarm codes

The Norstar ICS system generates alarm codes after system disconnections or after certain anomalies in system operation. All alarm codes appear at the Alarm telephone and in the System test log of a Maintenance session.

For a more complete description of alarm and event codes consult your technical support representative. The following figure shows an alarm code appearing on a Norstar Alarm telephone display.

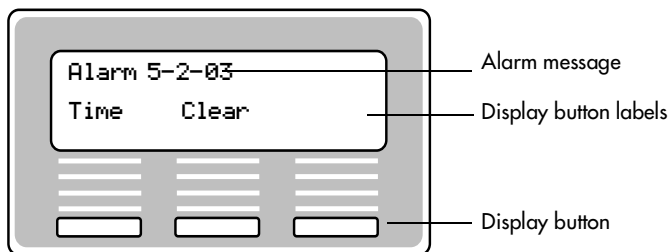

Tips - *The Alarm telephone is assigned in Featr settings of system programming.*

Alarms have a higher severity than events. Attend to alarm codes before event messages.

Alarm code information that is specific to Companion components is included in the Modular ICS Companion Installer Guide.

If you see an alarm code

1. Write the alarm code on the Sys test log record.
2. Determine the cause of the alarm from the following table.
3. Follow *Alarm troubleshooting* on page 510.
4. Press **TIME** to see when the alarm occurred.
5. Press **CLEAR** to clear the alarm.

An alarm code may not be displayed until two minutes after it has been triggered. If the ICS is powered off when the alarm is triggered, the alarm code is not displayed until two minutes after the ICS is powered on.

For a complete list of Norstar alarms, refer to the *Norstar Alarm & Event Code Manual*.

Displays

Example display	Meaning	Possible causes
Alarm: 10	All ICS devices disconnected.	The last device on Norstar bus 1 (port numbers 101-124) has been removed. A 25-pair cable was disconnected from the ICS. There is an internal ICS fault.

Example display	Meaning	Possible causes
Alarm: 37 ABBC DD	An error has occurred in the download of a protocol to a BRI Card. A: the maintenance index of the BRI BB: a code describing the nature of the error C: the current download state DD (appears when the error is limited to one protocol): the two-character product identifier of the protocol	The BRI Card is not properly installed.
Alarm: 40 Alarm: 41 Alarm: 42 Alarm: 43 Alarm: 44 Alarm: 45 Alarm: 46 Alarm: 47	There is a problem with the T1 signal	The cable connecting the DTI to the network termination point or external CSU is disconnected. There is a problem with the T1 signal from the network.
Alarm: 50 X	All devices on SM disconnected.	The last device on Norstar bus X (port numbers X01-X16) has been removed. The 25-pair cable was disconnected from the SM. The fiber cable from the SM to the ICS is disconnected. The SM was powered down.
Alarm: 51 X	Trunk Module disconnected.	All Trunk Cartridges are disconnected from the TM on DS-30 port X. The TM was powered down. The fiber cable from the TM to the ICS is disconnected.

Example display	Meaning	Possible causes
Alarm: 52 X Y	TC disconnected from TM	Trunk Cartridge Y on DS-30 port X is disconnected from the TM.
Alarm: 61 X Y	Incompatible Trunk Cartridge	Trunk Cartridge Y on DS-30 port X cannot operate with the Trunk type assigned to it in Configuration.
Alarm: 62 X Y	Unsupported Auto-answer setting (Loop Start TCs)	Trunk Cartridge X on DS-30 port Y does not support the auto-answer setting.
Alarm: 63 Z	No available DTMF receivers	DTMF receivers are busy, not working properly, or have not been installed.
Alarm: 68-Z	A device has been connected to a port which is not available for the device type.	Power down the system and disconnect the device from the port identified. Reconnect it to a valid port.
Alarm: 76 X	Data Module disconnected.	The Data Module is disconnected from the DM on DS-30 port X. The DM was powered down. The fiber cable from the DM to the ICS is disconnected.

X = DS-30 port numbers, Y = Trunk Cartridge number (numbered from left to right), and Z = Trunk port number

Alarm troubleshooting

Refer to the previous table before following these procedures.

Alarm: 10

1. Check to see if there is a device connected to the ICS (that has a port number beginning with the number 1).
2. If there are no devices connected to the ICS, connect one and then press **CLEAR**.
3. If there are any devices connected to the ICS, check all the wiring associated with the devices.
4. Refer to *Problems with BRI service* on page 570.

Alarm: 37

1. Check that the BRI Card is properly installed.
2. Remove and re-install the BRI Card.
3. If the alarm persists, replace the BRI Card with another BRI Card of the same type.

Alarm: 40 to Alarm: 47

1. Check the System Network evt log for events in the range 315-336 to verify the frequency of the alarms.
2. Refer to *Digital Trunk Interface trouble* on page 567.

Alarm: 50-X

1. Check that there is a device connected to the Station Module, which has a port number beginning with a number from three to eight.

2. If there are no devices connected to the Station Module, connect one and then press CLEAR.
3. If there are any devices connected to the Station Module, check all the wiring associated with the devices.
4. Refer to *Data Module down* on page 575.

Alarm: 51-X

1. Check the wiring from the ICS to the TM.
2. Refer to *Problems with trunk cartridges service* on page 566.

Alarm: 52-X-Y

1. Follow the procedure in *Problems with trunk cartridges service* on page 566.
2. If the problem persists, replace Trunk Cartridge Y on DS-30 port X.
Refer to the previous table for the definition of X and Y.

Alarm: 61-X-Y

1. Check that the proper Trunk Cartridges are inserted in the proper slots of the ICS or Trunk Module.
2. Enter programming and look under the `Trk/Line data` heading.
Check that the Trunk Cartridge type is correctly configured.
Check that the Trunk mode and Answer mode settings do not conflict for every line connected to Trunk Cartridge Y.
If Trunk mode is set to unsupervised, Answer mode must be set to manual.

OR

Install a Trunk Cartridge in slot Y that matches the type of trunk you have configured.

Alarm: 62-X-Y

1. Check that the proper Trunk Cartridges are inserted in the proper slots of the Trunk Module.
2. Enter programming and look under the **Trk/Line data** heading.
Check that the Trunk mode and Answer mode settings do not conflict for every line connected to Trunk Cartridge Y. If Trunk mode is set to unsupervised, Answer mode must be set to manual.

Alarm: 63-Z

1. Check that you have the required E&M Trunk Cartridges. There should be a maximum of one for every two auto-answer loop start lines installed in a Trunk Module.
2. Enter programming and look under the **Trk/Line data** heading. Check that the Answer mode is correct for all the loop start lines.
3. Make sure that all of your E&M trunks installed in a Trunk Module are configured as E&M or DTMF, whichever applies, so that the system knows the receivers are there.
4. If the problem persists, an E&M Trunk Cartridge may be malfunctioning. Replace one E&M Trunk Cartridge at a time until the problem is resolved.

Alarm 68-Z

1. Locate the device(s) connected to port(s) not available for that device type.
2. Power down the system.
3. Disconnect the device from the port identified.
4. Reconnect it to a valid port.

Alarm 75

1. Check the connection to your ISDN service provider.

Alarm: 76-X

1. Check the wiring from the ICS to the DM.
2. Refer to *Problems with trunk cartridges service* on page 566.
3. Refer to *Data Module down* on page 575.

Event messages

Event messages appear as items in the System administration log or the System test log of the Maintenance session. Most of these event messages can only be caused by an unusual combination of events, and should rarely occur.

Each event is assigned a severity number. An S preceding this number, S4 for example, may appear in the event message. S9 is the most severe. If the log is full, new event messages with a higher severity number replace existing event messages of a lower severity. For this reason, you should check event messages at regular intervals. You can then deal with all messages before they are replaced.

Event message information that is specific to Companion components is included in the *Modular ICS Companion Installer Guide*.

Dealing with event messages

For every event message that you see:

1. Record the event on the appropriate Maintenance record.
2. Refer to *Significant event messages*.
3. To see if the event caused the Norstar system to automatically restart, consult the table on *Event Message* on page 520.

Significant event messages

The following table lists event messages that are relevant to Maintenance activities. The time that the message is recorded is also provided.

Displays

Event message		The event message is recorded when...
Evt:210-YYYZ	S4	Loopback test YYY on Trunk Cartridge Z has started
Evt:211-YYYZ	S4	Loopback test YYY on Trunk Cartridge Z has stopped
Evt:220-3546	S4	the Sys admin log has been cleared by the DN (3546 in this case)
Evt:221-3546	S4	the Sys test log has been cleared by the DN (3546 in this case)
Evt:222-3546	S5	the DN (3546 in this case) enters the debugging facility that is password protected
Evt:255	S9	administered mode is not supported by the cartridge plugged into the slot
Evt:260-0302	S8	the ICS takes the access line on port 0302 out of service because no current was detected
Evt:261-0302	S1	the access line on port 0302 is returned to service after current was detected (see Evt:260)
Evt:263-302	S8	the ICS takes the E&M line on port 302 out of service because the far end did not respond to a disconnect signal
Evt:264-302	S1	the E&M line on port 302 is returned to service after the far end finally responded to a disconnect signal (see Evt:263)
Evt:265-302	S7	the E&M line on port 302 did not receive an expected wink signal or delay dial signal from the far end
Evt:267	S9	a data module has been disconnected
Evt:268-07	S8	Dialing filter 07 has lost data due to a fault in the system memory

Event message		The event message is recorded when...
Evt:269-3546	S8	the Line/set filter for the DN (3546 in this case) has lost data due to a fault in the system memory
Evt:299	S1	the system powers up after a power failure
Evt:327	S5	short term alarm threshold has been surpassed in the DTI cartridge
Evt:328	S5	short term alarm threshold has been surpassed in the DTI cartridge
Evt:329	S5	short term alarm threshold has been surpassed in the DTI cartridge
Evt:330	S5	short term alarm threshold has been surpassed in the DTI cartridge
Evt:336	S5	long term alarm has been surpassed in the DTI cartridge
Evt:373	S5	the ICS restart diagnostic tool has been activated
Evt:400	S9	Startup programming is performed using ☐ * * S T A R T U P
Evt:407	S2	there are no more codes for Speed Dial numbers
Evt:408	S2	there is no more memory for Speed Dial codes
Evt:412-3546	S5	the Installer password has been changed by the DN (3546 in this case)
Evt:413-3546	S3	the System Coordinator password has been changed by the DN (3546 in this case)
Evt:414-3546	S5	an invalid Installer password has been entered by the DN (3546 in this case)
Evt:415-3546	S3	an invalid customer password has been entered by the DN (3546 in this case)
Evt:416-3546	S4	programming is performed using ☐ * * C O N F I G
Evt:417-3546	S2	programming is performed using ☐ * * A D M I N
Evt:418	S7	a DN change is successful
Evt:419	S2	the time setting has been changed
Evt:421	S8	a DN change failed

Event message		The event message is recorded when...
Evt:422-3546	S6	a length change by the DN (3546 in this case) has been requested
Evt:423-3546	S6	an individual DN change has been requested by the DN (3546 in this case)
Evt:441	S2	a timeout occurred while waiting for ANI or DNIS digits to be received
Evt:442	S5	a timeout occurred while waiting for ANI or DNIS digits to be received
Evt:453	S4	Someone entering **CONFIG
Evt:454	S5	Invalid password entered
Evt:458	S4	Call-by-Call NVRAM data is corrupt
Evt:459	S9	DN length has been changed to less than 3 digits
Evt:680	S9	wireless system is disabled
Evt:681	S9	activation or recovery code entered
Evt:683	S9	new base station configuration detected
Evt:687	S4	the data driver has received a bad call reference
Evt:688	S4	the data driver has received a bad data event
Evt:689	S4	the data driver could not allocate a new index
Evt:690	S4	no response to the ICS within 10 seconds of being sent an initialization message
Evt:691	S4	no response to the ICS within 3 seconds
Evt:692	S4	a bad parameter value has been received in a stimulus message from the data device
Evt:693	S3	old data to be discarded has been detected
Evt:694	S4	RADAR flow control has received a bad stimulus message from an off-core application
Evt:695	S4	attached set denied request for a B-channel
Evt:696	S2	corrupt CLID length
Evt:697	S2	an asynchronous data report generated by SDI module

Event message		The event message is recorded when...
Evt:698	S8	incorrect software key entered
EVT799-00040B	S7	a call processing error on the fourth BRI loop; see <i>Event message 799</i> on page 518.
Evt:822	S8	Alarm code 63 is sent because there are no DTMF receivers for an incoming call
Evt:882	S9	mobility data re-evaluation sequence initiated
Evt:883	S4	an invalid dial pulse signal was received by the DTI
Evt:992	S6	auto attendant error

Event message 799

Event message 799 indicates a call processing error has occurred on an ISDN line. The event number is followed by a number representing the line or loop number, and a code for the type of error.

EVT799-XXXX YY57 In this example, the error has occurred on line XXX and the error code is YY.

Error code	Meaning
01	Internal software error. Cannot acquire the B-channel from the B-channel arbitrator.
02	Internal software error. There is no free line available for the call.
03	A call that is not on the B-channel has been attempted. These kind of calls are part of EKTS service, which is not supported by this version of the software. Check with your service provider to make sure your package does not include EKTS service.
04	Internal software error. Failed to instantiate on the chain.
05	Internal software error. Activation procedure failed.

Error code	Meaning
06	Internal software error. Index conversion failed.
07	Unexpected digits on a Manual answer mode line. Configuration of the ICS and the network connection may not match.
08	Internal software error. Cannot seize central office (CO) line on a BRI connection.
09	Cannot get vterm (virtual terminal) from the Vterm Server.
0A	Central office did not respond to the SPID initialization request.
0B	Central office has rejected the SPID. Verify your SPID information programmed under Hardware and with your ISDN service provider.
0C	Internal software error. Already instantiated on the chain.

Displays

You should rarely see any event messages that are not described in the *Significant event messages* on page 515. If you do see one of these event messages, the Norstar system has followed its normal recovery from an unusual combination of system events. Although the problem is not a serious one, repeated occurrences of the event number should be reported as soon as possible.

As a result of some events, the Norstar system automatically restarts itself. The table on the next two pages lists all the event numbers and tells you which of these events are associated with Norstar system restarts.

Most of these events are recorded in the Sys test log. The few exceptions to this are recorded in the Sys admin log, as indicated.

Event Message	System Restart	Event Message	System Restart
101-106	Yes	400 (Admin log)	Yes
107	No	401-403	No
108-112	Yes	405-411	No
113	No	412-419 (Admin log)	No
114-116	Yes	421-423 (Admin log)	No
117	No	424-425	No
118-120	Yes	426-430	Yes
121-123	No	431	No
124-125	Yes	432	Yes
126-129	No	433	No
130	Yes	441-442	No
131-132	No	453	No
133-134	Yes	454	No
135-136	No	458-459	No
137	Yes	600-602	Yes
138-150	No	603-613	No
151	Yes	614	Yes
152	No	615-629	No
160-164	No	630	Yes
170-173	No	631-646	No
200-211	No	680	No
220 (Admin log)	No	681	No
221-222	No	683	No
223 (Admin log)	No	689-698	No

Event Message	System Restart	Event Message	System Restart
224	Yes	799	No
225-228	No	800-802	No
229 (Admin log)	No	803	Yes
230-235	No	804-807	No
245-248	Yes	808	Yes
250-256	No	809	No
260-271	Yes	810	Yes
280-283	No	811-820	No
285-298	Yes	823	Yes
299	No	824-825	No
327	No	851	No
328	No	882	No
329	No	883	No
330	No	900	No
336	No	940-943	No
373	No	950-989	No

Provisioning BRI and PRI lines

This section discusses how you put BRI and PRI lines into and out of service.

BRI and T1 lines

Provisioning applies to BRI and T1 loops and lines. It allows you to place loops and lines in or out of service, either before or after the BRI Cards have been installed in the ICS.

When you provision a loop, ISDN terminals on the loop can be used to make outgoing calls or receive incoming calls (S or U-LT loop).

Loop lines are also available for use by the devices attached to the system (T, S, or U-NT loop). When you are configuring a T, S, or NT loop, you must also provision each line on the loop to place the lines in service.

Cd1-ICS

Installer password required

The card type will appear with the setting. If no card has been installed, you can change the card type under **Hardware**.

1. Press to display the loops found on the card.
2. Press **REMOVE** to take the loop out of service.
3. If lines on the loop are busy, the display will ask if you still want to remove the loop from service.
Press **YES** to go ahead.

L001

Installer password required

If the loop is configured as a U-NT, T or S loop, press and to display the individual lines. There are no lines associated with an S or U-LT loop.

1. Press **REMOVE** to take the line out of service.
2. If line is busy, the display will ask if you still want to remove it from service. Press **YES** to go ahead.

Provisioning a T1 line

Installer password required

Start with the display showing **Network ext. log**.

1. Press . **Provisioning** displays.
2. Select a module and card type, see *Show module* on page 455.
3. Press . **Show module:** displays.
4. Enter the number of the line to be provisioned. The display shows the line and its current status.
5. Press **PORT** to identify the logical port number for the line. Lines cannot be provisioned from the **PORT** display. Press **LINE** to return to the line number display.
6. Press to view settings for the next line number.
7. Press until you return to **Provisioning**.

Provisioning a PRI line

ISDN lines are provisioned by default. For information on adding a DTI card (configured as PRI) see *Cards on KSU* on page 455.

Deprovisioning a line

Deprovisioning all of the lines on a DTI does not disable the cartridge.

Disabling a PRI Channel

PRI channels can be disabled. However, there is no association between a line number and a b-channel. Disabling a b-channel can be done when you have fractional PRI. See *Fractional PRI* on page 540.

Tests

Norstar allows you to run tests which verify the integrity of the installation wiring for the telephones.

In addition, you can evaluate the transmission quality of a BRI loop through your service provider using a loopback test to evaluate different aspects and segments of the T1 digital transmission path. You can only run one loopback test at a time on any one DTI.



Choose an appropriate time to run tests.

Do not run the loopback tests while ports are being disabled or during the first two minutes after Startup programming. If you do, the tests may stop running with ports still disabled. To recover from this, unplug the ICS from the power outlet, then plug it in again.

The loopback tests disrupt service. Do not run tests during busy user times.

Loopback tests for T1 or ISDN-PRI lines

Installer password required

The following messages may appear on the Alarm Telephone during Loopback tests.

Message	Explanation
EVT: 210-YYYZ	Loopback test YYY on Trunk Cartridge Z has started
EVT: 211-YYYZ	Loopback test YYY on Trunk Cartridge Z has ended

Line loopback

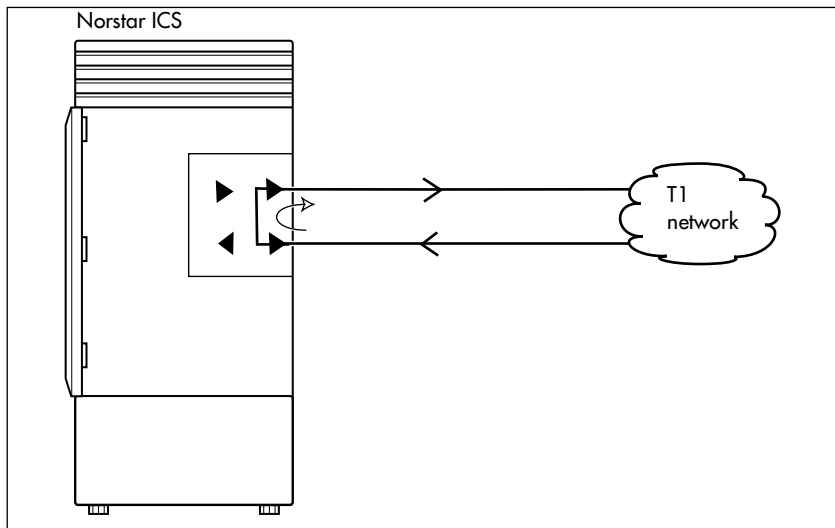

The line loopback test loops the full 1.544 Mbps signal received from the network back to the network. The looped signal is regenerated without any change in the framing format and without the removal of any bipolar violations. The line loopback test can also be invoked and stopped remotely using the in-band signal or via the facility data link (FDL) in extended super frame (ESF) format.

The line loopback test must be run in coordination with the T1 or PRI service provider. Some test patterns can cause the DTI to reset. To avoid this, start the line loopback test from your system before the T1 or PRI service provider begins their test, and stop the line loopback test from your system after the T1 or PRI service provider ends their test.

Payload loopback

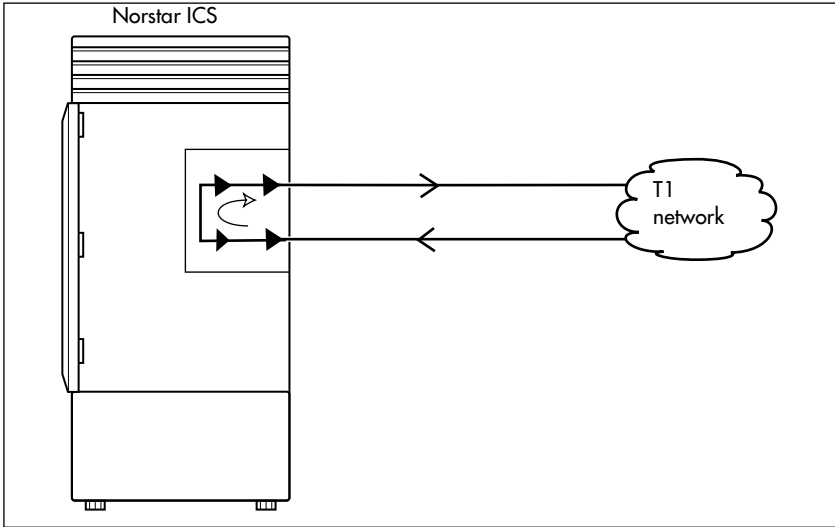

The payload loopback test loops the received information bits (192 per frame) back to the network. The payload loopback test can also be invoked and stopped remotely via the facility data link (FDL) in extended super frame (ESF) format.

The payload loopback test must be run in coordination with the T1 service provider. Some test patterns can cause the DTI to reset. To avoid this, start the payload loopback test from your system before the T1 service provider begins their test, and stop the payload loopback test from your system after the T1 service provider ends their test.

Card edge loopback

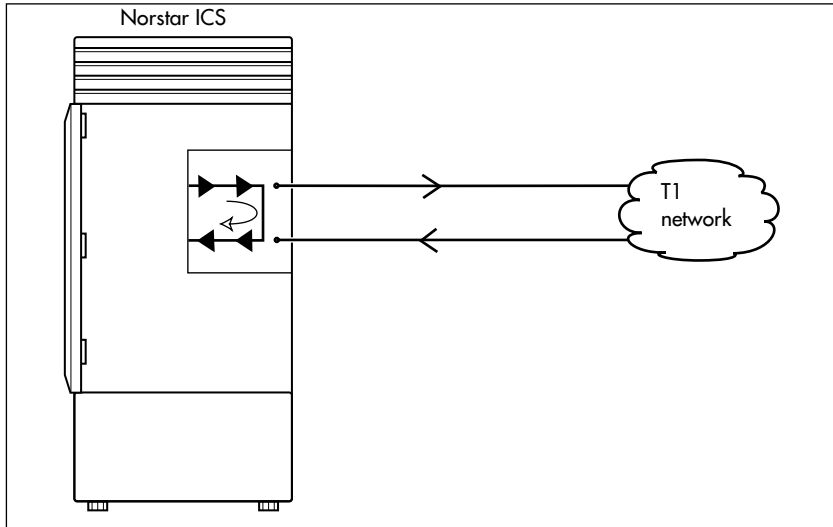

The card edge loopback test loops the outgoing signal on the DTI back to its internal received signal path. Signal paths to the external network are disconnected.

Continuity loopback

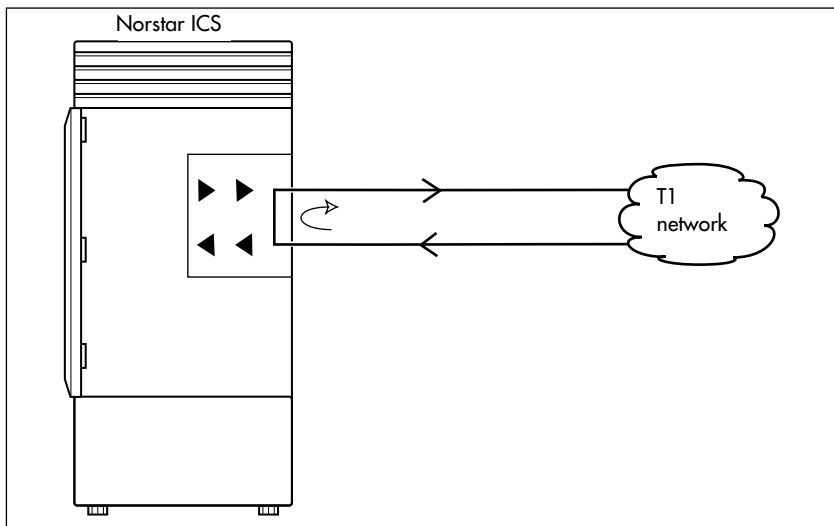

The continuity loopback test shorts the tip and ring pair of the receive signal path with the transmit signal path. This test allows you to check the metallic continuity of the external wiring.

Tests initiated from Norstar

You can start and stop Loopback tests in **Maintenance** programming under the heading **Loopback tests**. You can also push a button on the DTI faceplate to start and stop the continuity test.

You can run DTE and DS30 Loopback tests to verify the SDI data transfer capabilities. Under the **Hardware** heading, ensure that the **Type** setting for data module is **SDI** before choosing the Loopback test you will run.

Tests initiated by the central office

If the internal CSU is administered on line loopback and payload loopback tests can also be invoked and stopped by the central office. In order to be able to run a payload loopback test, the DTI must be configured for extended superframe format.

Starting a loopback tests

Installer password required



Give notice that you are running a loopback test.

Calls on all T1 or PRI lines on the DTI will be automatically dropped when a loopback test is invoked. Use the Page feature to notify people using the system that a test is about to begin and that calls will be disconnected.

Start with the display showing **Loopback tests:**

8. Press . **Show Module:** displays.

9. Press . **Cards on KSU** displays.

If you want to test cartridges on another module, press until the display shows the module.

10. Press . **Cd1-KSU** displays.

If you want to test the second cartridge on the KSU, press . The display shows **Cd2-KSU**.

11. Press .

If there is an analog cartridge in the slot or the slot is empty, the display shows **Need digital crd.**

12. Press until the display shows the test you want to run: **Continuity loopback, Line loopback, Payload loopback, Card edge loopback.**

13. Press START to begin the test. The display shows the test name followed by **running**.

14. Press STOP to end the test.

Operating a Continuity loopback test Installer password required

You start the Continuity loopback test by pressing the button on the front of the DTI. Calls on all lines on the cartridge are automatically dropped when a loopback test is invoked.



Give notice that you are running a loopback test.

Calls on all T1 or PRI lines on the DTI will be automatically dropped when a loopback test is invoked. Use the Page feature to notify people using the system that a test is about to begin and that calls will be disconnected.

- The red LED above the button remains on until the test is canceled.
- Invoking a Continuity loopback test automatically cancels any other test in progress.
- To stop the continuity loopback test, press the button on the DTI. The red LED above the button turns off when the test is canceled.

Loopback test for BRI lines

Installer password required

The loopback test for BRI lines loops the incoming BRI payload back to the local exchange (service provider) for evaluation of the transmission quality. Loopback tests should be conducted only under the guidance of the service provider, and the results from these tests are returned to the service provider.

You can run loopback payload tests simultaneously on multiple loops or multiple cards. The loop must be provisioned to perform the test. All calls on the card you are testing will be dropped at the start of a loop payload test.

Operating a payload loopback test

Installer password required



All calls on a BRI loop are dropped when you start loopback test.

While the loopback test is in progress, the BRI lines go out of service. There is no warning from the system. Pick an appropriate time to do a test and warn users that they will lose any calls in progress.

Start with the display showing **Loopback tests:**

15. Press . **Show Module:** displays.
16. Enter a module number or press **LIST** to scroll through modules. **Cards on KSU** or **Card on Mod X** displays.
17. If you want to test cartridges on another module, press until the display shows the module.
18. Press . **Cd1-KSU** or **Cd1-ModX** displays.
If you want to test the second cartridge on the KSU, press to display **Cd2-KSU** or **Cd1-ModX**.
19. Press .
 - If there is an analog cartridge in the slot or the slot is empty, the display shows **Need digital crd.**
 - If there is a BRI cartridge with U-NT or S/T loops, the display shows **LOOP nnn.**
20. Press . **Payload loopback** displays.
21. Press **START** to begin the test. **Payload running** displays.
22. Press **STOP** to end the test.

Note: You can exit programming or move on to other programming or loop testing while the test is running.

CSU stats

Each DTI is equipped with an internal channel service unit (CSU). When enabled, the internal CSU monitors the quality of the received T1 signal and provides performance statistics and diagnostic information.

DTIs must be individually programmed to establish parameters for collecting and measuring transmission performance statistics by the CSU.

Statistics

Installer password required

The CSU provides both performance and alarm statistics. Three performance parameters are accumulated:

- errored seconds (ES-P)
- severely errored seconds (SES-P)
- unavailable seconds (UAS-P)

These parameters are defined as per TIA-547A. Errored seconds are enhanced to include control slip (CS) events.

The parameters are stored for the previous 15-minute interval, the 15-minute intervals in the last 24 hours, and the previous 24-hour interval. Only near-end performance data is recorded.

The internal CSU continuously monitors the received signal and detects four types of transmission defects:

- any active carrier failure alarms (CFA) — loss of signal LOS, out of frame OOF, alarm indication signal AIS, remote alarm indication RAI
- the number of bipolar violations that occurred in the last minute

- any defects that occurred in the last minute — loss of signal LOS, out of frame OOF, alarm indication signal AIS
- the number of milliseconds of short term alarms in the last minute — loss of signal LOS, out of frame OOF, alarm indication signal AIS, remote alarm indication RAI.
A shortterm alarm is declared when the detected defects persist for tens of milliseconds.

A carrier failure alarm (CFA) is a duration of carrier system outage. CFA types reported can be mapped to CFAs defined in TIA-547A and TR62411 as follows:

Norstar	TIA-547A	TR62411
LOS CFA	Red CFA	Red CFA
OOF CFA	Red CFA	Red CFA
AIS CFA	Red CFA	AIS CFA
RAI CFA	Yellow CFA	Yellow CFA

The criteria for declaring and clearing the alarms is selectable to meet those in TIA-547A or TR64211.

Checking the performance statistics Installer password required

To check the performance statistics, start with the display showing **CSU stats**:

1. Press . **Show card:** displays.

If the ICS is not equipped with DTIs, or if both cartridges have their internal CSU setting programmed to off, the display shows **UNEQUIPPED**.

2. Press or depending on which Trunk Cartridge you are checking. **Cd1-KSU** or **Cd2-KSU:** displays.
3. Press to see the results.

4. Press **TIMER**. The display shows the date and time that the system began collecting statistics.
5. Press . **Performance stats** displays.
6. Press to view the performance stats. **Current interval** displays.
7. Press to display the duration of the current interval.

OR

Press until the display shows the type of interval statistics you want to check. Options are:

- **15 min intervals** for intervals in the last 24 hours, numbered from the most recent (01) to the oldest (96). Press , then enter an interval number, or press to view the most recent interval. The display shows the start time of the interval.
 - **24 hour summary** for a summary of the previous 24 hours. Press to display the number of intervals in the summary.
8. Press . **ES:** displays the number of errored seconds.
 9. Press . **SES:** displays the number of severely errored seconds.
 10. Press . **UAS:** displays the number of unavailable time seconds.
 11. Press until the display shows **Performance stats**.

Checking the CSU alarms

Installer password required

To check the CSU alarms, start with **Performance stats**.

1. Press . **Alarm stats** displays.
2. Press . **Active alarms** displays.

Checking active alarms

Installer password required

Start with the display showing **Active alarms**.

1. Press . The display shows the first active alarm or no active alarms.
2. Press or to cycle through the complete list of active alarms.
3. Press to return to **Active alarms**.

Checking carrier failure alarms

Installer password required

Start with the display showing **Active alarms**.

1. Press . **CFA alarms** displays.
2. Press .

The display shows one of the following:
LOS CFA history, **DOF CFA history**, **RAI CFA history** or **AIS CFA history**.

3. Press until the display shows the type of alarms you wish to view.
4. Press . The display shows the first history item and the time that the alarm started.
5. Use and to move through the history items.

Checking bipolar violations

Installer password required

Start with **Active alarms**.

1. Press until you find **Bipolar violatn**.
2. Press . The display shows the number of bipolar violations that occurred in the last minute.

Checking short term alarms

Installer password required

Start with **Active alarms**.

1. Press until you find **ShortTerm alarms**.
2. Press .

The display shows the first type of shortterm alarm and the number of milliseconds, not necessarily contiguous, it was active in the last minute.

3. Press and to move through the short term alarms.

Checking defects

Installer password required

Start with **Active alarms**.

1. Press until you find **Defects**.
2. Press .

The display shows the first type of defect and the number of milliseconds, not necessarily contiguous, the hardware reported it active in the last minute.

3. Press and to move through the defects.

Resetting all statistics

Installer password required

Start with the display showing **Alarm stats**:

1. Press . **Stats log** displays.
2. Press . **Reset stats?** displays.
3. Press **YES** to erase all the current statistics and begin collecting statistics again.

Diagnostic tools

The command under this heading allows you to perform a warm restart on your system.

1. At the **Diagnostic** prompt, press .
`Restart system?` displays.
2. If you are sure you want to perform a warm start on your system, press **YES**. Otherwise, press **CANCEL**.

Link Status

Fractional PRI

When you purchase PRI from your service provider, you can request the number of B-channels that are allocated for you to use. For example, you may want to use only 12 B-channels instead of 23 B-channels. If this is your situation, you should disable all the B-channels that you do not need.

It is recommended that the number of lines that are deprovisioned on a DTI card (configured as PRI) be the same as the number of B-channels that are disabled. For example when B-channels 13-23 are disabled, you should deprovision lines 13 to 23.

Start with the display showing **Maintenance**

1. Press . **System version** displays.
2. Press until you find **Link status**.
3. Press . **Cards on KSU** displays.
4. Press . **Cd1-KSU: PRI** displays.
5. Press . **B channel** displays.
6. Press . You can view the status of the PRI channel, for example: **PRI:B01 Idle**.

Note: When the display shows **PRI:B01 Near**, it means that the channel has been disabled by Norstar.

When the display shows **PRI:B01 Far**, it means that the channel has been disabled by the CO.

7. Press **Enable** or **Disable** key to change the setting for the channel or press to move to the next B-channel.

Usage Metrics

Hunt groups

Installer password required

This feature gives you statistical information about hunt group calls.

From **Usage Metrics**, start with the display showing **Hunt groups**.

1. Press . **Show group:** displays.
2. Enter the group number. **H91 metrics** displays.
3. Press . The display shows the date the information was last cleared.
4. Press . **TotalCalls:** displays.

The displayed value is the total number of calls received by the hunt group, up to a maximum value of 99999.

5. Press . **Ans:** displays.

The displayed values are the number of calls that were answered up to a maximum value of 99999 and the percentage of answered calls versus total calls up to a maximum value of 999.

6. Press . **Avg ans: . sec** displays.

The displayed value is the average time in seconds that it took to answer a call, up to a maximum value of 999.

7. Press . **Abndn:** displays.

The displayed values are the number of calls that were abandoned up to a maximum value of 99999 and the percentage of abandoned calls versus total calls up to a maximum value of 999.

8. Press . **Busy:** displays.

The displayed values show the number of times the hunt group was busy up to a maximum value of 99999 and the percentage of busy call versus total calls up to a maximum value of 999.

9. Press . **Overf1:** displays.

The displayed values show the number of calls that were sent to the overflow position up to a maximum value of 99999 and the percentage of overflow calls versus total calls up to a maximum value of 999.

10. Press . **Avg Q: sec** displays.

The displayed value is the average time, in seconds, that the call waited in the queue, up to a maximum value of 999.

Call-by-Call

Installer password required

This feature gives you statistical information on call-by-call limit settings for PRI when the protocol is set to call-by-call routing.

From Usage Metrics, start with the display showing **CbC limit stats.**

1. Press .

The display shows the first pool (PRI-A or PRI-B) that supports CbC routing. Press **NEXT** to show the other pool if it is supported.

2. Press . **Service:** displays.

The service that is displayed depends upon the protocol. Press **NEXT** to select a different service.

3. Press .

The display shows the supported call type for the selected service.

4. Press to select the next supported call type, either **Incoming calls** or **Outgoing calls**.

For **Incoming calls** press .

The display shows **Min denied: __**.

Press . The display shows **Max denied: __**.

For **Outgoing calls** press .

The display shows **Min denied: __**. Press .

The display shows **Max denied: __**.

Note: The value for Min denied and Max denied can be from 0 to 999.

Clearing the metrics

After step 1 in the previous section, press **CLR** to clear the Min and Max denied metrics values for all call types and all supported services for that pool.

Troubleshooting

These troubleshooting procedures allow you to solve many problems in the Norstar system.

Follow these procedures before replacing any components.



Only qualified persons should service the system.

The installation and service of this unit is to be performed only by service personnel having appropriate training and experience necessary to be aware of hazards to which they are exposed in performing a task and of measures to minimize the danger to themselves or other persons.

Electrical shock hazards from the telecommunication network and AC mains are possible with this equipment. To minimize risk to service personnel and users, the ICS must be connected to an outlet with a third-wire ground. In addition, all unused slots should have filler faceplates installed and the doors should be in place at the completion of any servicing.

Service personnel must be alert to the possibility of high leakage currents becoming available on metal system surfaces during power line fault events near network lines. A risk point on the ICS is the power cord earth ground pin. These leakage currents normally safely flow to Protective Earth ground via the power cord.

Therefore, it is mandatory that connection to an grounded outlet is performed first and removed last when cabling to the unit. Specifically, operations requiring the unit to be powered down must have the network connections (central office lines) removed first.

Where more than one procedure is given, the procedures represent different options from which you can select one.

Troubleshooting procedures for Companion components are included in the *Modular ICS Companion Installer Guide*.

Getting ready

Before you begin troubleshooting, gather all the information that is relevant to your network configuration:

- the *Modular ICS Programming Record*
- records from people who use the network
- information about other hardware and non-Norstar features within the public or private network



Notify service provider of T1 or PRI signaling disruption.

Notify your T1 or PRI service provider before disconnecting your T1 or PRI lines, removing power to your system, or performing any other action that disrupts your T1 or PRI signaling. Failure to notify your T1 or PRI service provider may result in a loss of T1 or PRI service.



Tips - Remember that you can check many of the system parameters without having to go into a programming session.

Use Line Profile (☎ * * L I N E) from a T7316, an M7310 or an M7324 set, to check programming for any line.

Use Set Profile (☎ * * S E T) from a T7316, an M7310, or an M7324 telephone, to check programming for any telephone.

Use Button Inquiry (☎ * 0) to check the buttons on a particular telephone.

Types of problems

The problems you encounter will likely occur into one of the following categories:

Misunderstanding a feature

A problem may be reported because a Norstar user is unfamiliar with the operation of a given feature. You may be able to solve the problem simply by demonstrating how to use the feature correctly.

Programming errors

You may encounter problems caused by errors in programming. A feature may have been programmed incorrectly or may not have been programmed at all. Refer to the section on programming the feature to ensure all the parameters have been correctly programmed.

Wiring connections

Wiring problems are caused by loose, unconnected, or incorrect wiring. Use the procedures in the section on Checking the hardware as a guide.

Equipment defects

You may encounter problems caused by Norstar equipment defects. See the appropriate section for problems related to the system hardware.

General troubleshooting procedure

1. Diagnose the trouble by determining:
 - the types of problems users have experienced
 - the frequency of the problems
 - how many telephones are affected
2. Check how a feature is being used.

A problem may have been reported because of a misunderstanding about how a feature works. Confirm that the person who reported a problem understands the intended use and operation of any feature in question.
3. Check for programming errors.

Check that the programming recorded in the *Programming Record* is correct for the intended operation of the system, and verify that the programming has been correctly entered.
4. Run a Station set test (☎ 8 0 5).

Instructions are included in the *Modular ICS 6.0 System Coordinator Guide*.
5. Check the wiring and hardware connections.
6. If the problem persists, run a Maintenance session as described in *Beginning a Maintenance session* on page 486.
7. If hardware is defective, replace it.
8. If the trouble requires expert advice, follow your company procedure for obtaining assistance.

Problems with telephones

Set has faulty buttons, display, handset or other hardware problems

Run a Station Set Test (☎ 8 0 5).

Detailed instructions are contained in the *Modular ICS 6.0 System Coordinator Guide*.

Unreadable set display

If the trouble is with an M7310, T7316, or an M7324 sets

1. Press ☎ * 7.
2. Press UP or DOWN to adjust the display to the desired level.
3. Press OK.



Tip - *The number of contrast settings varies with the model of telephone.*

If the trouble is with an M7100, T7100, M7208 or T7208 sets

1. Press ☎ * 7.
2. Press a number on the dialpad to adjust the display to the desired level.
3. Press OK.

If the display is still unreadable

1. Go into **Maintenance** in programming and disable the problem telephone.
2. Replace the problem telephone with a working one.
3. Enable the working telephone.

Telephone dead

1. Run a Station Set Test ( 8 0 5).

Detailed instructions are contained in the *Modular ICS 6.0 System Coordinator Guide*.

2. If more than one telephone is affected, refer to *Data Module down* on page 575.
3. Check for dial tone.
4. Check the display.
5. If the problem persists, replace the telephone with a working set of the same type. This ensures the programming is downloaded to the new set.
6. Check the internal wiring at both the modular jack and the distribution cross-connect. A TCM port should have between 15 and 26 V DC across the Tip and Ring when the telephone is disconnected.
7. Check the line cord.

Running a Maintenance session to test a dead telephone

1. Run a Maintenance session to ensure that the telephone is not disabled. See *Port/DN status* on page 488.
2. Disable the port that the telephone is connected to using *Port/DN status*.
3. Enable the port that the telephone is connected to using *Port/DN status*.

Replacing a telephone

In a powered-up system, an existing telephone can be replaced by a new telephone. A new telephone is one that was not previously in service within the system.

Replacing telephones of the same type

If an existing telephone is unplugged, and a new telephone of the same type is then plugged into the same jack, for example, replacing a T7208 set with another T7208 set, the new telephone acquires the programmin gand the internal number of the old telephone. This is normally done to replace a defective telephone.

Replacing telephones of different types

If an existing telephone is unplugged, and a new telephone of a different type is plugged into the same jack, the new telephone keeps the old internal number. The new telephone receives a default profile for a telephone of its type. You then need to program the terminal as described in the *Modular ICS 6.0 System Coordinator Guide*.

If the telephone being replaced has more lines than the new telephone, automatic outgoing line selection may not work with the Handsfree feature. A line must be selected manually.

Status of a telephone that was replaced

The old telephone that was unplugged and replaced by a new telephone loses its programming and internal number. The internal number of the old telephone has been given to the new telephone. The programming has either been removed or given to the new telephone when it was plugged into the old jack. The replaced telephone, if it is plugged back into the system, is now treated by the system as a telephone not previously in service.

Emergency telephone dead

1. Verify that the power at the ICS or Trunk Module is not on.
2. Verify that there is no dial tone at the emergency telephone.
3. Check that the external line and emergency telephone connections have been made correctly.
4. Ensure that the emergency telephone is not faulty by connecting it directly to the external line and listening for dial tone.
5. Verify that the ICS has a Loop Start Trunk Cartridge installed in slot 4. Verify that the Trunk Module has a Loop Start Trunk Cartridge installed in the left-most slot.
6. Verify that there is dial tone on lines 002 (ET1 on CD1) and 026 (ET2 on CD2) of the ICS and on the first line of each Trunk Module.
7. Replace the ICS if the emergency telephone is connected to the ICS or replace the Trunk Module if the emergency telephone is connected to the Trunk Module.

Problems with lines

The troubleshooting problems listed here focus on trouble with making calls or using lines. For problems which are specific to BRI lines, refer to *Problems with BRI service* on page 570.

Calls cannot be made (but can be received)

1. Press  * 0 .
2. Press a line button.
3. If an incorrect line number or name appears, or if neither appears, on the display, check the programming settings.

OR

If the correct line number or name appears on the display, make sure the external lines are properly cross-connected.

4. Check external lines by attaching a test telephone directly on the distribution block.
5. Ensure that the 25-pair cable is properly connected to the modules or the ICS.
6. Run a **Maintenance** session.
7. Use **Module status** to verify that the module the Trunk Cartridge is installed in is not disabled or unequipped.
8. Run a **Maintenance** session and disable the appropriate ports using **Port/DN status**.
Charts showing external line port number defaults appear under *Wiring charts* on page 241.
9. Enable the appropriate ports using **Port/DN status**.



10. If you still cannot make external calls, power down, then power up the system. This should be done after business hours, to avoid losing calls.
11. To check the line, contact your service provider or central office.



Notify service provider of T1 signaling disruption.

Notify your T1 service provider before disconnecting your T1 lines, removing power to your system, or performing any other action that disrupts your T1 signaling. Failure to notify your T1 service provider may result in a loss of T1 service.

Dial tone absent on external lines

1. Use Button Inquiry (  ) to display the number of the external line you are testing.
2. Check for dial tone using a test telephone at the connections for the external line on the distribution block.
3. Make sure that a Trunk Cartridge for the line is properly installed in the ICS or Trunk Module.
4. Make sure that the Trunk Module fiber cable is properly connected to the Expansion Cartridge on the ICS. Refer to *Problems with trunk cartridges service* on page 566 and *Trunk or Station Module down* on page 574.
5. Run a Maintenance session to ensure that the line is not disabled. See *Port/DN status* on page 488.

Hung lines at a telephone

Line indicators that have been solid for a long time are the only visible indication that lines are hung.

Possible problem

A line that has been redirected using Line Redirection may, under some circumstances, remain busy after a call is over. If this happens, the outgoing line for the redirection also remains busy. You can clear this kind of hung line only at the telephone that was used to redirect the line.

Solution

1. Enter the Button Inquiry feature code () at the telephone that was used to redirect the line.
2. Press the button of the redirected line.
3. Press SHOW or .
4. Press DROP or .

Both the redirected line and the outgoing line for the redirection should now be cleared.

Possible problem

The supervision and/or Discon timer programming for the line do not match the settings for the line at the central office.

Solution

Verify that your programming for the line matches the central office settings.

Possible problem

Lines are still hung after all the above solutions have been investigated or tried out.

Solution

For lines that are hung for any other reason, you will have to run a Maintenance session.

1. Run a Maintenance session and go to Module status.
2. Disable and enable the affected Trunk Cartridge.

Follow the procedures in the *General troubleshooting procedure* on page 548 before proceeding.

Auto-answer line rings at a telephone

This section describes possible problems and solutions if an auto-answer line mistakenly rings at a telephone.

Possible problem

You configured a loop start trunk as auto-answer but the installed hardware does not support disconnect supervision. In this case, the symptom would be accompanied by the Alarm 62 code symptom.

Solution

Reconfigure the trunk as manual-answer.

OR

Replace the Trunk Cartridge with one that provides disconnect supervision.

Possible problem

The line is configured as auto-answer and unsupervised.

Solution

Reconfigure the line as manual-answer.

OR

Reconfigure the line as supervised.

Possible problem

The line is not equipped for disconnect supervision at the central office.

Solution

Reconfigure the trunk as manual-answer.

Possible problem

The Discon timer setting for the Trunk Cartridge in `Trk/Line data` does not match the setting for the line at the central office.

Solution

Reconfigure the Discon timer to match the setting at the central office.

Prime telephone gets misdialed calls

This section describes possible problems if the Prime telephone is receiving calls that it should be routed elsewhere.

Possible problem

The digits sent by a switch at a central office or in the private network did not match any Received number, the Auto DN, or the DISA DN. The call has been routed to the prime telephone for the incoming trunk.

Solution

1. Verify that the switch is sending the correct number of digits for the Received number length defined in your system.
2. Verify all the digit strings that the switch should be sending.
3. Check that you have defined the corresponding Received number for every target line in your system.
4. Make sure that the published telephone numbers for your network are correct.

Selected lines reads Not in service or Not available

When a user selects a line button and the set displays either Not in service or Not available, refer to the problem explanations in this section.

Possible problem

You have configured a line number associated with an E&M Trunk Cartridge DTMF receiver to appear at the telephone.

Solution

Reconfigure the line so that it does not appear at any telephone and configure another line to replace it at the telephone.

OR

Reconfigure the line as a different type and install trunk hardware to support the new type of line.

Possible problem

The Norstar system has taken an E&M line out of service because the far end did not respond to a disconnect signal from the Norstar system. The symptom would be accompanied by event code 263 in the System test log.

Solution

1. Check with the operators of the system at the far end and find out if their system is operating.
2. Check that your system hardware is receiving signals properly.
3. Check the trunk between your system and the far end system for a break.
4. Check that your trunk is properly configured.
5. Run a Maintenance session and go to the heading `Module status`.

6. Disable and enable the affected Trunk Cartridge.

Possible problem

The Norstar system has detected no response on an E&M line from the system at the far end. The symptom will be accompanied by Event code 265 in the System test log.

Solution

Check with the operators of the system at the far end and get them to troubleshoot their system.

Possible problem

The line is connected to a DTI which is currently not in service.

Solution

1. Check if the green LED on the DTI is flashing to indicate that service is suspended.
2. Check if any yellow LEDs are on to indicate an alarm or error condition.
3. Check if the red test LED is on to indicate that a continuity loopback test is running.
4. Check that the cable connecting the DTI to the termination point from the central office or network is properly connected.
5. Check that the DTI is properly inserted in the ICS.
6. Run a Maintenance session to verify the status of the DTI.

Possible problem

The line has been disabled for maintenance purposes.

Solution

Enable the line.

OR

If the line will be out of service for some time, configure another line to replace it on the telephone.

Possible problem

The loop or line has not been provisioned.

Solution

Provision the loop or line.

Selected line pool displays: No free lines

If the user selects a line pool and the telephone displays No free lines, refer to this section for solutions.

Possible problem

If this happens often, there are not enough lines in the line pool to serve the number of line pool users.

Solution

If the line pool contains loop start trunks, enter programming and move under-used loop start trunks from other line pools into the deficient line pool.

OR

If the line pool contains E&M trunks, order more trunks from the telephone company or private network vendor. Install additional Trunk Cartridges of the appropriate type. In programming, add the new trunks to the deficient line pool.

Problems with optional equipment

Analog Terminal Adapter

1. Check the connections to the jack.
2. Check the connections to the ATA.
3. Disconnect the ATA and replace it with a working telephone. If the telephone still works properly, the ICS and/or the SM are operating properly.
4. Verify that the programming has been done as described in the *Programming Record* and the *Norstar Analog Terminal Adapter Installation Card*.
5. If the trouble seems to be in the ICS or SM, double-check all wiring and programming options. Also refer to *Problems with BRI service* on page 570 or *Data Module down* on page 575.

OR

If the trouble seems to be with the ATA, disable the ATA and replace it with a known working one.

Running a Maintenance session to test an ATA

1. Run a Maintenance session to ensure that the ATA is not disabled. See *Port/DN status* on page 488.
2. Disable the port connected to the ATA using *Port/DN status*.
3. Enable the port connected to the ATA using *Port/DN status*.

Auxiliary ringer

1. If the auxiliary ringer is used for **Schedules** (Night, Evening, or Lunch service), ensure that **Schedules** is activated from the control telephone.
2. Check the wiring between the auxiliary ringer generator and the ringing device. Refer to the auxiliary ringer wiring chart.
3. Check the wiring between the auxiliary ringer generator and the distribution block:

Auxiliary ringer wiring

Feature	Pin
Auxiliary ring (Make)	44 (Yellow-Brown)
Auxiliary ring (Common)	19 (Brown-Yellow)

4. Ensure that the auxiliary ringer contacts are operating properly by checking with an ohmmeter across the auxiliary ringer pin contacts listed above.
5. Check that the auxiliary ringer pin contacts are programmed to operate in conjunction with any or all of the features in the auxiliary ringer programming chart shown below.

Auxiliary ringer programming

Feature	Programmed in
Auxiliary ringer	Terminals&Sets
Auxiliary ringer	Lines
Schedules	Services

The current capacity of the Norstar relay contacts is 50 mA DC. They are designed to operate with the auxiliary ringer generator, or equivalent.

External paging

1. Use the Button Inquiry feature (*) to verify the feature of a programmable memory button.
2. Check the wiring between the 50-pin connector and the paging amplifier or between the connections shown in the external paging wiring chart.

External paging wiring

Feature	Pin
Page out (Tip)	40 (Black-Slate)
Page out (Ring)	15 (Slate-Black)
Page (Make)	41 (Yellow-Blue)
Page (Common)	16 (Blue-Yellow)

3. Test external paging () to ensure that it is working. The nominal output signal from the Norstar ICS is 100 mV across 600 Ω .

Music on Hold/Background Music trouble

Although Music on Hold and Background Music are separate features, they share the same wiring and customer-supplied music source.

1. Ensure that the proper feature access code () is turned on. Adjust the volume using the volume control bar.
2. Use the Button Inquiry feature (*) to verify the feature on a programmable memory button.
3. If there is trouble with Music on Hold or Background Music, check **Featr settings** in **System prgming**.
4. Check the wiring between the music source and the 50-pin connector. See *Wiring charts* on page 241.

5. Ensure that the music source is turned on, is operational, and the volume control is set properly.
6. Any music source with a low-output impedance, less than $3,300\ \Omega$, can be connected. The output level must be less than one volt.

Problems with trunk cartridges service

Check first for user problems, then wiring and programming errors before replacing Norstar equipment.



Notify service provider of T1 or PRI signaling disruption.

Notify your T1 or PRI service provider before disconnecting your T1 or PRI lines, removing power to your system, or performing any other action that disrupts your T1 or PRI signaling. Failure to notify your T1 or PRI service provider may result in a loss of T1 or PRI service.

1. Check that the cartridge is properly inserted in the ICS or Trunk Module.
2. Run a **Maintenance** session to ensure that the cartridge is not disabled.

If the problem persists:

If the Trunk Cartridge is installed in the ICS and the AC power is present and the LED indicator on the ICS is off, replace the ICS.

If the Trunk Cartridge is installed in a Trunk Module:

1. If AC power is present and the LED indicator on the Trunk Module is off, replace the Trunk Module.
2. Replace the fiber cable.
3. Replace the Trunk Cartridge.
4. Replace the Expansion Cartridge.
5. Replace the ICS.

Refer to *Installation* on page 209 for information about replacing components.

Digital Trunk Interface trouble

1. Run a **Maintenance** session to verify that the Trunk Cartridge is enabled and that the lines are provisioned.
2. Check the LEDs on the front of the DTI:

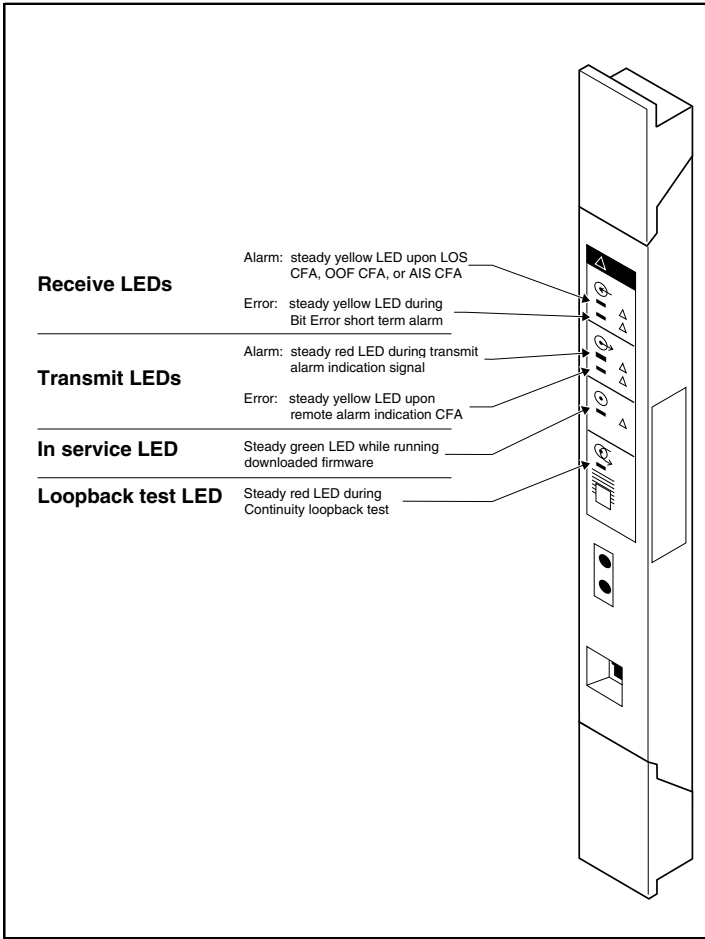

- **Receive Alarm** — yellow LED on indicates a problem with the digital transmission being received. This half-duplex link is unusable.
 - **Receive Error** — yellow LED indicates a minor error as a result of degraded digital transmission. Possible causes are an ohmic connection, water ingress, or too long a loop.
 - **Transmit Alarm** — red LED on indicates an inability to transmit. Alarm indication signal (AIS) is being transmitted to the terminating switch. This half-duplex link is unusable.
 - **Transmit Error** — yellow LED on indicates a remote alarm indication (RAI) carrier failure alarm (CFA) is being sent to the terminating switch. If the Transmit Alarm is not on, this indicates a far-end or cable problem.
 - **In service** — a flashing green LED indicates that the T1 or PRI trunks are out of service because of a running loopback test, or because the DTI is being initialized.
 - **Loopback test** — red LED on while a continuity loopback test is running.
 - **All LEDs flashing continuously** — the DTI is being initialized.
3. Run a **Maintenance** session and any loopback tests as appropriate.
 4. Check the pinout of the cable that connects the DTI to the termination point from the T1 or PRI service provider or the external channel service unit, and check that the cable is properly connected.
 5. Check with your T1 or PRI service provider to see if through-fed repeaters are used on the T1 or PRI span. The DTI does not provide the DC connection required for through-fed repeaters.

If through-fed repeaters are used on the T1 span, disable the internal CSU and connect the DTI to an external CSU.

6. If the problem persists, replace the DTI.



Notify service provider of T1 or PRI signaling disruption.

Notify your T1 or PRI service provider before disconnecting your T1 or PRI lines, removing power to your system, or performing any other action that disrupts your T1 or PRI signaling. Failure to notify your T1 or PRI service provider may result in a loss of T1 or PRI service.

Monitoring the T1 or PRI signal

If you are finding minimal faults with the T1 or PRI signal, you can monitor the signal to try and isolate the problem. The monitor jack on the DTI faceplate provides non-intrusive, bridged in-service monitoring of the T1 or PRI signal. Connect a protocol analyzer or other test equipment into the monitor jack to monitor the signal received from the network, and the signal transmitted by Norstar.

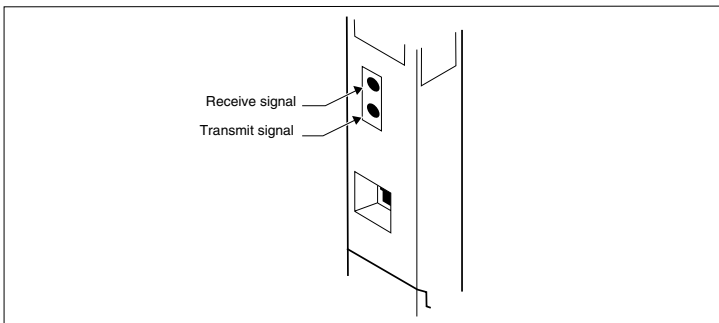

Problems with BRI service

Each LED on front of a BRI-ST or BRI-U Card corresponds with a loop, or indicates an overall state of the BRI connections.

BRI Card indicators

LED status	S, T or U-NT loop	S or U-LT loop
on	normal operation	
off	no synchronization with ISDN network	no synchronization with TE
all flashing	Card is not recognized by ICS (not configured in Hardware as a valid BRI loop). <i>All the LEDs on a BRI Card are flashing on page 571.</i>	
bottom LED only flashing	ICS is downloading firmware to the card; card is new or has changed location, or Feature Cartridge has been upgraded	

The BRI card is connected to the ISDN network (U loop) but the LED for one of more loops is not lit

Possible problem

The physical connection or configuration for the network connection is not correct (no Layer 1).

Solution

1. Verify the wiring from the network to the distribution block.
2. Verify the wiring from the distribution block to the ICS.
3. Use a Meridian 2500 set to test for data on the BRI trunk.
4. Test the network connection by connecting Bellcore standard terminal equipment (TE) directly to the network.

5. Verify that the loop is provisioned.
6. Verify that the loop is properly configured, including the proper loop type, SPIDs, and Network DNs.
7. Disable and re-enable the BRI Card.
8. Disable and enable the module for the Card.

Out of service displays when a BRI is selected (LED for loop is lit)

Possible problem

The loop is configured incorrectly. Layer 1 is present but Layers 2 and 3 are not working.

Solution

1. Verify that the SPIDs and Network DNs are programmed correctly in Hardware.
2. Verify that the loop and lines are provisioned.

All the LEDs on a BRI Card are flashing

Possible problem

The card is not configured properly.

Solution

Verify that the loop is properly configured, including the proper loop type, SPIDs, and Network DNs.

Possible problem

The card is not recognized by the ICS.

Solution

1. Verify that an Expansion Cartridge with Clocking, or Clocking Cartridge is installed in the ICS.
2. Replace the card with another card of the same type.

Caller hears one ring and then a fast busy signal when placing a call on a BRI line

Possible problem

CACH or EKTS, which are not supported by Modular ICS, is included in the ISDN services package.

Solution

1. Contact your service provider and ensure that CACH or EKTS are not part of the ISDN services package. These services must be turned off at the switch.
2. Verify that the network DNs have been programmed correctly, and verify the numbers with your service provider.

ICS down

1. If AC power is present and the LED indicator on the ICS is off, replace the ICS power supply.
2. Disconnect all central office and station lines from the ICS. Power down the ICS by unplugging it.

Replacing the ICS power supply

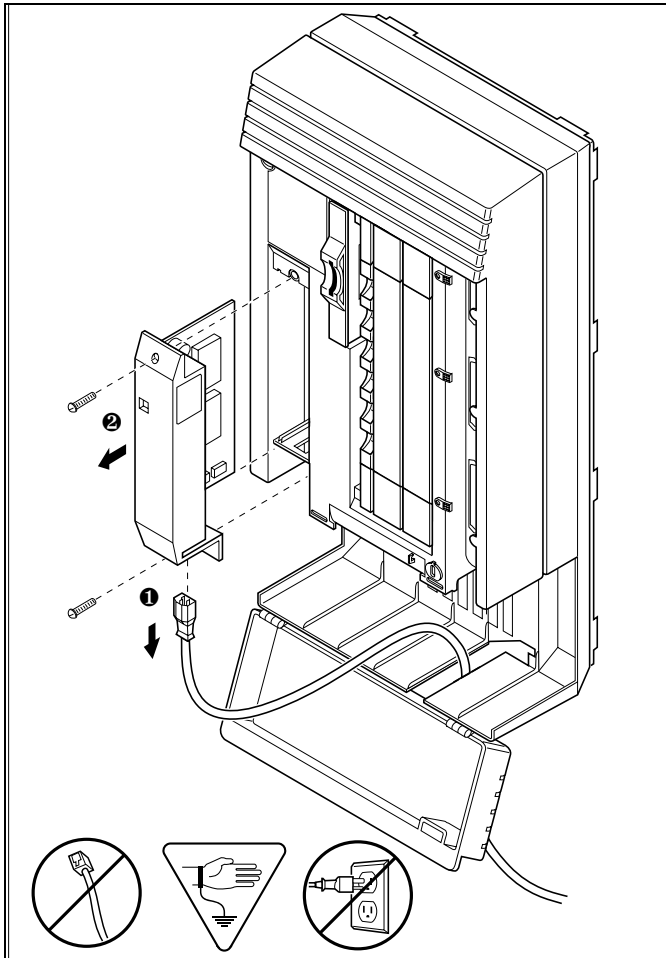

Trunk or Station Module down

1. Run a **Maintenance** session to ensure that the Trunk Module is not disabled. See *Module status* on page 495.
2. Disable the module using the **Maintenance** heading **Module status**.
3. Enable the module using the **Maintenance** heading **Module status**.
4. For Trunk Module

Check the external line by terminating a single-line telephone directly on the distribution block, or equivalent, which connects to the Trunk Module.

5. For Station Module

If the Station Module is still down, power down, then power up the ICS.

If the problem persists

1. If AC power is present and the LED indicator on the Trunk Module is off, replace the Trunk Module.
2. Replace the fiber cable.
3. Replace the Trunk Cartridge.
4. Replace the Expansion Cartridge.
5. Replace the ICS.

Refer to *Installation* on page 209 for information on replacing components.

Data Module down

1. Run a **Maintenance** session to ensure that the module is not disabled. See *Module status* on page 495.
2. Disable the Data Module using **Module status**.
3. Enable the Data Module using **Module status**.
4. If the Data Module is still down, power down, then power up the ICS and the Data Module.

If the problem persists

1. If AC power is present and the LED indicator on the Data Module is off, replace the Data Module.
2. Replace the Fiber cable.

Problems for network or remote users

Remote feature code gets no response

Possible problem

A Norstar user has called into another Norstar system and is trying to activate a remote feature but gets no response after dialing the feature code.

Solution

1. Make sure that the remote caller is dialing the feature code correctly. Use the asterisk (*) character, followed by the feature code, to activate a remote feature.
Do not use for accessing features on a remote Norstar system.
2. Make sure that the remote user is dialing tones, not pulses, once the call is answered.

Dialed number gets ringback and the wrong person

Possible problem

The digits sent by a switch at a central office or in the private network did not match any Received number, the Auto DN, or the DISA DN. The call has been routed to the prime telephone for the incoming trunk.

Solution

1. Verify that the switch is sending the correct number of digits for the Received number length defined in your system.

2. Verify all the digit strings that the switch should be sending.
3. Check that you have defined the corresponding Received number for every target line in your system.
4. Make sure that the published telephone numbers for your network are correct.

Dialed number gets stuttered dial tone instead of ringback

Possible problem

The remote caller has tried to reach a Norstar target line, but has reached a trunk with DISA instead.

Alternatively, the Norstar system has mapped incoming digits onto the DISA DN.

Solution

1. Verify all the digit strings that the switch should be sending.
2. Check that you have defined a corresponding Received number for every target line in your system.
3. Check that you have defined the correct DISA DN for your system.
4. Make sure that the published telephone numbers for your network are correct.

Dialed number gets dial tone instead of ringback

Possible problem

The remote caller has tried to reach a Norstar target line, but has reached the Norstar system instead. Norstar has mapped the incoming digits onto the Auto DN.

Solution

1. Verify all the digit strings that the switch should be sending.
2. Check that you have defined the corresponding Received number for every target line in your system.
3. Check that you have defined the correct Auto DN for your system.
4. Make sure that the published telephone numbers for your network are correct.

Dialed number gets busy tone

Possible problem

The target line that the incoming digits map onto is busy, and there is no prime telephone for the incoming trunk.

Solution

For maximum call coverage, make sure that you configure a prime telephone for every incoming trunk.

Dialed number does not get through

Possible problem

The digits sent by a switch at a central office or in the private network did not match any Received number, the Auto DN, or the DISA DN. There is also no prime telephone assigned for the incoming trunk. In this case, the caller may hear overflow tone from the Norstar system or a recorded message from the originating switch.

Solution

1. Configure a prime telephone for every incoming trunk.
2. Verify that the switch is sending the correct number of digits for the Received number length defined in your system.
3. Verify all the digit strings that the switch should be sending.
4. Check that you have defined a Received number for every target line in your system.
5. Make sure that the published telephone numbers for your network are correct.

Possible problem

The Norstar system did not receive some or all of the incoming digits.

Solution

1. Check that the system hardware is receiving signals properly.
2. Verify that the switch is sending the correct number of digits for the Received number length defined in your system.

3. If the switch at the far end is sending pulse signals, make sure they are being sent at the proper rate. Pulse digits must be 300 ms or more apart for Norstar to receive them.

Possible problem

If remote callers are having difficulty getting through from the public network, there may be a problem with your DID Trunk Cartridge.

Solution

1. Connect a single-line DTMF telephone to a DID trunk input on the DID Trunk Cartridge.
2. Use the single-line telephone to enter a Received number that has been programmed for a target line in your system. Listen for ringback.
3. If you do not hear ringback, check that the target line is assigned to a telephone and that there is a prime telephone assigned for the DID trunk.
4. If you now hear ringback, but you also hear the noise of your unanswered call ringing, check the cross-connections. If all the cross-connections are correct replace the Trunk Cartridge.

Possible problem

If remote callers are having difficulty getting through from the private network, there may be a problem with your E&M/DISA Trunk Cartridge.

Solution

1. Check the cross-connections for the E&M/DISA Trunk Cartridge.

2. If the E&M trunks are connected to another Norstar system, make sure that connections have been made as indicated in *Installation* on page 209.
3. Use the following table to check for correct voltage on the E&M/DISA leads:

Voltages on E&M leads

Leads	Voltage: active	Voltage: inactive
V _{T-R}	125 mV AC on steady dial tone	0 V AC
V _{T1-R1}	125 mV AC on steady dial tone	0 V AC
V _{E-SG}	0 V DC to -5 V DC	-48 V DC
V _{M-SB}	0 V DC to + 2 V DC	-48 V DC

Dialed DISA number gets ringback instead of stuttered dial tone

The remote caller has dialed a DISA number, but has instead reached a target line, or has been routed to the prime telephone for the auto-answer trunk. The Norstar system has mapped the incoming digits from a switch onto a target line, or has been unable to map the digits anywhere.

Solution

1. Verify that the switch is sending the correct number of digits for the Received number length defined in your system.
2. Verify all the digit strings that the switch should be sending.
3. Check that you have defined the correct DISA DN for your system.
4. Make sure that the published telephone numbers for your network are correct.

Dialed DISA number gets dial tone instead of stuttered dial tone

Possible problem

The remote caller has dialed a DISA number, but has reached the Norstar system instead. The Norstar system has mapped the incoming digits from a switch onto the Auto DN.

Solution

1. Verify that the switch is sending the correct number of digits for the Received number length defined in your system.
2. Verify all the digit strings that the switch should be sending.
3. Check that you have defined the correct DISA DN for your system.
4. Make sure that the DISA DN and Auto DN are different enough to prevent misdialing.
5. Make sure that the published telephone numbers for your network are correct.

DISA user gets overflow tone when entering COS password

Possible problem

The remote caller may have entered an invalid password.

Solution

Check programming under COS passwords and verify that the caller has a valid password.

Possible problem

The remote caller may have entered an asterisk (*) as one of the six digits.

Solution

Instruct remote callers to enter their COS password correctly: enter six digits.

Possible problem

The remote caller may have entered a number sign (#) as one of the six digits.

Solution

Instruct remote callers to enter their COS password correctly: enter six digits. The number sign (#) may be entered after the sixth digit, but is not required.

Possible problem

The remote caller may have waited more than 15 seconds between entering digits.

Solution

Instruct remote callers to enter their COS password correctly: enter six digits, and do not pause too long between digits.

Possible problem

The caller may be dialing from a rotary-dial telephone or from a push-button telephone that uses pulse signaling.

Solution

Inform remote callers that they must dial from a push-button telephone that uses DTMF tone signaling.

Dialed feature code gets overflow tone

Possible problem

The remote caller does not have access to that feature.

Solution

1. If the call came in on a trunk with DISA, check the Class of Service that is associated with the COS password of the remote caller. If it is too restrictive, modify the remote package assigned to the COS password, or assign another COS password that is more suitable.
2. If the call came in on a trunk without DISA, check the remote package that you assigned to the incoming trunk. Make sure that it gives the appropriate access to the remote caller.

Possible problem

The feature code is not valid.

Solution

1. Make sure that remote callers have a correct listing of the features that are programmed for remote access.
2. Ensure that remote callers are dialing the feature code correctly. Press followed by the feature code to activate a remote feature.

Possible problem

The caller may be dialing on a rotary-dial telephone or on a push-button telephone that uses pulse signaling.

Solution

Inform remote callers that they must dial from a push-button telephone that uses DTMF tone signaling.

Dialed feature code gets busy tone

Possible problem

A resource that the remote feature uses may currently be in use. For example, a remote caller trying to use the paging feature would get a busy tone if the auxiliary speaker were being used at the time.

Solution

If repeated attempts to use the remote feature get busy tone, there may be a malfunction in a resource that the feature uses. Check that the remote feature hardware is functioning normally.

Line pool access code gets overflow tone

Possible problem

If the published line pool access code is valid, the remote caller does not have access to that line pool.

Solution

If the incoming trunk answers with DISA, give the remote caller a COS password that permits access to that line pool.

OR

Change the remote package for the incoming trunk so that it permits access to that line pool.

OR

Give the remote caller a line pool access code that is permitted within the Class of Service on the incoming trunk.

Possible problem

If the published line pool access code is invalid, the system has attempted, without success, to match the invalid code to a Norstar target line internal number, and there is no prime telephone for the auto-answer trunk.

Solution

1. Make sure that the published line pool access codes are correct.
2. Check that the line pool access codes have been entered correctly under `Access codes in System prgming`.

Possible problem

The caller may be dialing from the network on a rotary-dial telephone or on a push-button telephone that uses pulse signaling.

Solution

Inform remote callers that they must dial from a push-button telephone that uses DTMF tone signaling.

Line pool access code gets ringback

Possible problem

The published line pool access code is invalid, and the system has routed the call to the prime telephone for the incoming trunk.

Solution

1. Make sure that the published line pool access codes are correct.
2. Check that the line pool codes have been entered correctly under `Access codes in System prgming`.

Line pool access code gets busy tone

Possible problem

There are not enough lines in the line pool to serve the number of users.

Solution

If the line pool contains loop start trunks, enter programming and move under-used loop start trunks from other line pools into the deficient line pool.

OR

If the line pool contains E&M trunks, order more trunks from the telephone company or private network vendor. Install additional E&M Trunk Cartridges. In programming, add the new trunks to the deficient line pool.

OR

Create a separate line pool for remote users only.

Possible problem

There are DID lines in the line pool.

Solution

In programming, make sure that there are no DID lines in any of the line pools.

Dialed number gets no response

Possible problem

The remote caller, after accessing a line in a line pool, may have started dialing before the far end was ready to receive.

Solution

Instruct remote callers to wait until they hear feedback before entering any digits.

Possible problem

There may be a malfunction in the line that the remote caller accessed.

Solution

If the problem is persistent, check that all lines in the affected line pool are functioning normally.

Possible problem

There may be a malfunction in the system that the caller is trying to reach.

Solution

Inform the operators of the system at the far end that the dialed number is not getting through.

Specifications

Norstar system

Service tone cadences

Tone	Cadence (seconds)
Busy	0.5 on / 0.5 off
Expensive Route	0.3 on / 0.3 off (3 bursts)
Overflow	0.25 on / 0.25 off
Ringback	2.0 on / 4.0 off
Confirmation	1.0 on / 1.0 off (three bursts followed by no tone)
Recall	1.0 on / 1.0 off (three bursts followed by steady tone)
Ring splash	0.2 on (one burst)

Power specifications

Characteristic	ICS	TM	SM
Voltage V ac	110-120	110-120	110-120
Current A rms (max)	2.6	1.75	1.0
Frequency Hz	47-63	45-70	45-70
Crest factor	4.0	4.0	4.0

Telephone loop specifications

Characteristic	Value
Loop resistance	64 $\frac{3}{4}$ (300 m of 0.5 mm wire or 1000 ft. of 24 AWG wire)
Loop length	300 m (1000 ft.) without station auxiliary power supply 790 m (2500 ft.) with station auxiliary power supply
Minimum voltage at telephone	10 V dc

Current at telephone (idle)	45 mA nominal
Current at telephone (active)	80 mA maximum

Electrical requirements

Characteristic	Spec/Value
Electrostatic discharge	
ICS and telephones	IEC 801-2 severity level 3 maximum of 15 kV with a 300%/150 pF probe
Connectors	IEC 801-2 severity level 2
Radiated immunity	maximum of 5 V/m from 100 kHz to 1 GHz
Conducted immunity	maximum of 3 V rms from 0.1 MHz to 30 MHz

Environmental requirements

Characteristic	Spec/Value
Operating temperature range	0°C to 50°C (32°F to 122°F) IEC. 68-2-1 Tests Ad and IEC 68-2-2, Method A
Storage temperature range	-50°C to 70°C (-31°F to 158°F) IEC. 68-2-2 Test Bd
Humidity above 34°C (93°F)	5% to 95% (non-condensing) <52 mbar of water vapor pressure

ISDN network synchronization*

Characteristic	Spec/Value
Free run clock accuracy	±32 ppm
Network synchronized clock accuracy	±5 ppm

- * These specifications only apply when the system clock is not derived from a Digital Trunk Interface connection to the network.

Digital Trunk Interface

Network interface

Characteristic	Spec/Value
Physical	RJ48C 8-pin modular jack
Line rate	1.544 +/- 32 Mbps
Framing	Superframe/extended superframe*
Line code	AMI/B8ZS*
Impedance	100 Ω

* These values are set in Hardware programming. See the *Hardware on page 455* for details.

DSX1 operation

Characteristic	Value
Pre-equalization	0-210 m (0-700 ft.)*

* This value is set in Hardware programming. See the *Hardware on page 455* for details.

CSU operation

Characteristic	Spec/Value
Line build out	0, 7.5 or 15 dB*
Input dynamic range	0 to -26 dB (typical)
Performance reporting	Simultaneous support of TR 54016 or TIA-547A
Line loopback support	Remote activation/deactivation via in-band code or FDL as per TR 54016 or TIA-547A
Payload loopback support	Remote activation/deactivation via FDL as per TR 54016 or TIA-547A
Carrier failure alarms (CFA)	Alarm indication signal (AIS), Red Yellow

* This value is set in Hardware programming. See the *Hardware on page 455* for details.

Synchronization performance

Characteristic	Spec/Value
Stratum	4E

Digital trunk signaling support

Types	Options
Loop Start with answer and disconnect supervision	OSI interval* Pulse/DTMF dialing*
E&M	Immediate start (Pulse dialing only), Wink start, Delay start or ring-down tie line* Pulse/DTMF dialing*
DID	Immediate start (Pulse dialing only), Wink start or Delay start* Pulse/DTMF dialing* Ground start

* These values are set in Hardware programming. See the *Hardware on page 455* for details.

Local test support

Characteristic	Value
Monitor jack	Bridging via Bantam jack
Line loopback	activate/deactivate via maintenance*
Payload loopback	activate/deactivate via maintenance*
Card edge loopback	activate/deactivate via maintenance*
Continuity loopback	activate/deactivate via push button on faceplate*

* See *Tests on page 525* for details on running these tests.

A

AbsorbLength: A setting that determines how many of the digits in a destination code will not be dialed by the system. AbsorbLength is assigned under **Destination codes** in **Services**.

access code: Different sequences of characters used to gain access to these Norstar features: Line pools, Call park, external lines, Direct-Dial telephone, Auto DN, and DISA DN.

alarm code: A number that appears on the alarm telephone display, informing you that the ICS has detected a fault in the system.

alarm telephone: A telephone that is designated to receive reports of Norstar system problems. This function is usually assigned to a prime telephone, but this can be changed under **Feature settings** in **Sys Programming**.

Analog Terminal Adapter (ATA): A device that permits analog telecommunication devices such as fax machines, answering machines, and single line telephones to be connected to the Norstar system. Programmed defaults for the ATA are automatically assigned by the Norstar system.

ANSI: American National Standards Institute.

Answer button: A telephone button with an indicator that is used to monitor another telephone. The answer button indicates incoming calls destined for the other telephone. Someone working at a telephone with answer buttons (an attendant, for example) can receive all ringing and visual indication of incoming calls for other telephones, and answer those calls when necessary.

One telephone can have up to four Answer buttons. An Answer button is automatically assigned to a telephone when that telephone is assigned an Answer DN.

Answer DN: The internal or directory number (DN) of a telephone that is monitored by an Answer button. You can assign up to four Answer DNs to a telephone under **Line Access** in **Terminals** and **Sets** programming.

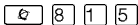
Autobumping:  A feature that determines what the system does with new Call Log items when your Call Log is full. When Autobumping is on, a new log entry causes the oldest entry to be deleted. If Autobumping is off, your Norstar system does not log calls when your log is full.

autodial button: A memory button that, if programmed, provides one-touch dialing of external or internal numbers.

autolog options:  A feature that allows you to select the type of calls that are stored in your Call Log. You can choose to log calls that were not answered by anyone within the system, to log calls that were unanswered at this telephone but which were answered elsewhere in the system, to log all calls answered and not answered at this telephone, or to not have calls automatically logged.

Automatic Dial: A feature that allows you to dial without having to pick up the receiver or select a line. You must have a prime line to use Automatic Dial. Automatic Dial is assigned under **Dialing options** in **Terminals&Sets** programming.

Automatic Handsfree: A feature which automatically activates Handsfree operation when you make or answer a call. Automatic Handsfree is assigned under Handsfree in **Terminals&Sets** programming.

Automatic Hold: A feature that automatically places an active call on hold when you select another line. Automatic Hold (**Full AutoHold**) is assigned in **Lines** programming.

Automatic Privacy: See Privacy.

Automatic Daylight Savings

Time: A feature that switches the system to standard or daylight savings time at pre-programmed times. It is turned on or off under **Daylight time** in **Sys Prgrmmng**.

Automatic Telephone

Relocation: A feature that allows a telephone to retain personal and system programming when the telephone is plugged into a different Norstar modular jack. **Automatic Telephone Relocation** is enabled under **Set relocation** in **Sys Prgrmmng**.

auxiliary ringer: A separate external telephone ringer or bell which can be programmed to ring when a line or a telephone rings. An auxiliary ringer may be programmed to ring only when the system is in a particular schedule. Programming of an auxiliary ringer is done in **Services** programming after the feature has been enabled under **Capabilities** in **Terminals&Sets** programming.

AWG: American wire gauge.

B

B channel (Bearer channel). An ISDN standard transmission channel used for voice or data transmission.

Base station (XC 3.0 only): A Companion component that is mounted on walls and ceilings to provide a radio link to an office or other area where Companion portable telephones are used. Each base station houses two radios that allow portables to send and receive calls through the ICS. (See also Companion Wireless)

Background Music: A feature that allows you to hear music from the speaker of your Norstar telephone. It is available only if a music source has been attached to the ICS and the feature has been enabled under **Feature settings** in **Sys Prgrmmng**.

Basic password: A one- to six-digit password that prevents unauthorized access to the most commonly-used telephone settings. The Basic password can be assigned and changed in **Passwords** programming.

Basic Rate Interface (BRI): An ISDN interface which uses two B channels and a D channel (2B+D).

Bearer channel: See B channel.

Business series terminals These terminals were developed to replace the Norstar M-series terminals. Therefore, their functionality closely parallels the M-series terminals.

busy lamp field (BLF): A device with a liquid crystal display (LCD) panel of indicators that shows the status of up to 24 telephones in the Norstar system. The BLF attaches to the M7310 and T7316 telephones.

button caps: Interchangeable plastic caps that fit over the buttons of Norstar telephones. They are used to indicate the

features programmed onto each programmable memory button. Button caps are either pre-printed or have clear windows that allow you to insert labels.

Button Inquiry:

With this feature you can check the function of each programmable button on your system telephone.

C

Call Duration timer:

A feature that allows you to see how long you spent on your last call, or how long you have been on your present call.

Call Forward:

A feature that forwards all the calls arriving at your telephone to another telephone in your Norstar system. To have calls forwarded outside the system, use Line Redirection.

Call Forward No Answer: A feature that forwards all calls arriving at your telephone to another designated telephone in your Norstar system after a specific number of rings. **Call Forward No Answer** is assigned under **Capabilities in Terminals&Sets** programming.

Call Forward On Busy: A feature that forwards all calls at your telephone to another designated telephone if your telephone is busy. This feature is assigned under **Capabilities in Terminals&Sets** programming.

Call Forward Override: An automatic system feature that allows you to call someone and ask them to stop forwarding their calls to you.

Call Information:

Call Information allows you to display information about incoming calls. For external calls, you can display the caller name, telephone number and the line name. For an internal call, you can display the name of the caller and the

internal number. You can obtain information about ringing, answered, or held calls.

Call Information Trunk Cartridge:

The Trunk Cartridge that allows you to connect loop start trunks with Call Information capability to the Norstar system.

Call Log:

Enter your Call Log to view a record of incoming calls. The log could contain the following information for each call: sequence number in the Call Log, name and number of caller, long distance indication, indication if the call was answered, time and date of the call, number of repeated calls from the same source, and name of the line that the call came in on. See Autobumping, Autolog options, and Call Log for further information.

Call Park:

With this feature you can place a call on hold so that someone can retrieve it from any other telephone in the Norstar system by selecting an internal line and entering a retrieval code.

The retrieval code appears on the display of your telephone when you park the call. You can park up to 25 calls on the system at one time.

Call Park Callback: See Callback.

Call Park prefix: The first digit of the retrieval code of a parked call. This digit cannot conflict with the first digit of any existing DNs, Line Pool access codes, the Direct-dial digit, or the external line access code. The default Call Park prefix digit is 1. It may be set to none, in which case Call Park is disabled. **Call Park Prefix** is assigned under **Access codes in Sys PRGRMMNG**.

Call Pickup Directed:

A feature that allows you to answer a call ringing at any system telephone by entering the internal number of that

telephone before taking the call. Call Pickup Directed is enabled under Feature settings in Sys Prgrmmng.

Call Pickup Group: See Pickup Group.

Call Queuing:

If you have several calls waiting at your telephone, you can invoke the Call Queuing feature to answer them in order of priority. Priority is given to incoming calls, followed by callback and camped calls.

Callback: If you park, camp, or transfer a call to another telephone and it is not answered there, it will ring again at your telephone. How long the system will wait before Callback occurs is set under Feature settings in Sys Prgrmmng.

Camp-on:

A feature that allows you to reroute a call to a telephone even if all the lines on that telephone are busy. To answer a camped call, use Call Queuing or select a line if the camped call appears on your telephone. Priority is given to queued calls.

Camp timeout: The length of a delay before a camped call is returned to the telephone that camped the call. The length of delay is set under Feature settings in Sys Prgrmmng.

Central answering position

(CAP): An M7324 telephone that has been designated as a CAP under CAP assignment in Sys Prgrmmng. The CAP provides backup answering and can be used to monitor the telephones within a Norstar system.

Central answering position (CAP) module: A module connected to an M7324 telephone which provides 48 additional buttons that can be used as

autodial buttons or feature buttons. A maximum of two CAP modules can be connected to a single M7324 telephone.

Centralized voice mail and Auto Attendant: A Norstar VAM can be configured to service other systems connected to the Norstar where the NVAM resides. The connection must be made using PRI SL-1 lines with the MCDN protocol active. Both a PRI and an MCDN software codes (as well as any required voice mail codes) are required for this feature.

Channel Service Unit (CSU): A device on the Digital Trunk Interface that is the termination point of the T1 lines from the T1 provider. The CSU collects statistics on the quality of the T1 signal. The CSU ensures network compliance with FCC rules and protects the network from harmful signals or voltages.

Class of Service (COS): The set of Norstar features and lines available to the user for a call. The Class of Service for a call is determined by the restriction filters and remote access packages assigned to the telephone in Lines programming. The Class of Service for a call can be changed by entering a six-digit Class of Service password. (Internal users cannot change their access to features with a COS password, only their restriction filters.) Class of Service and Class of Service Passwords are assigned in Passwords programming. See Remote Access.

Class of Service password:

A six-digit code that allows you to switch from your current Class of Service to one that allows you to dial numbers prohibited by your current Class of Service.

cold start: When all system programming is lost. This can happen because you have entered the Startup

feature code

[☎] [*] [*] [S] [T] [A] [R] [T] [U] [P], or after a major event, such as an extended power failure.

Combo Cartridge: A cartridge that allows you to connect Trunk Modules and Station Modules to the ICS to expand the system capacity for trunks and telephones. Combo Cartridges provide six-port or 12-port expansion and Services functionality with each cartridge. See also Expansion Cartridge.

Companion Wireless: The name for Nortel Networks communication systems which use radio technology to transmit and receive signals between its components and the Norstar system. Companion Wireless provides mobility in the workplace. Calls that used to ring just at your Norstar set can also appear and ring at your portable.

Companion portable telephone: Hand-held wireless sets which allow complete mobility within the reach of Companion base stations or an external antenna. Portables offer many, but not all, Norstar features and share much of the same programming as wired desk sets.

Conference: **[☎] [3]**

A feature allows you to establish a three-person call at your Norstar telephone.

contrast adjustment: **[☎] [*] [7]**

Allows you to set the contrast level of your telephone display.

control telephone: A control telephone can place the lines for which it has responsibility in or out of a Service Mode.

The direct-dial telephone is a control telephone for directing calls to the extra direct-dial telephone. A telephone is made a control telephone and has lines assigned to it in Services programming.

Coordinated Dialing Plan: (CDP)

This dialing plan uses a steering code to identify each node in a private network. This one-digit code becomes part of the set DN number rather than a separate code. In this way, system A might have codes in range 2100 to 2999, whereas system B might have codes in range 3100 to 3999.

COS: See Class of Service.

cursor: A short horizontal line that appears on the system telephone display to indicate that characters can be entered using the dialpad.

D

D channel (Data channel): An ISDN standard transmission channel which is packet-switched, and is used for call setup, signalling and data transmission.

Data channel: See D channel.

Data Communications Interface (DCI): A Norstar device that allows you to attach an RS-232 data device to the Norstar system.

data terminal: A device, such as a modem, that can be used to transfer data instead of sound over a telephone network. You cannot use Norstar programming to set up such devices. See the documentation that accompanies the device.

date: See Show Time or Time and Date.

defaults: The settings for all Norstar features when the system is first installed. Settings are changed from their defaults in programming. In this manual, default settings are shown in **bold** text.

Delayed Ring Transfer (DRT) to prime: After a specified number of rings, this feature transfers an unanswered call on an external line, to

the prime telephone associated with that line. This feature is activated under **Feature settings in Sys PRGMMNG**.

destination code: A two- to seven-digit number that the system interprets and then translates into the digits that you want dialed out. Both the code and its associated dialed digits are assigned under Routing service in Services programming.

DID trunk: See Direct Inward Dial trunks.

DID Trunk Cartridge: The Trunk Cartridge that allows you to connect DID trunks to the Norstar system.

dialing restriction: See Restriction filter.

dialing modes:    

This feature allows you to set the dialing mode of your telephone. Norstar supports three dialing modes: Automatic Dial, Pre-Dial, and Standard Dial. All three modes support on-hook dialing, meaning you can dial a call without picking up the receiver. The special features of the Automatic and Pre-Dial modes are available only when you dial on-hook.

Digital Trunk Interface: The Trunk Cartridge connects digital T1 AND ISDN trunks to the Norstar system.

Direct-dial: A feature that allows you to dial a designated telephone in your Norstar system with a single digit, such as the main receptionist. As many as five direct dial sets can be established. Each telephone in the system is assigned to one direct-dial telephone. There is a single, system wide digit for calling the assigned direct-dial telephone of any telephone. Direct-dial telephones are established in System programming. Telephones are assigned to a direct-dial telephone under **Capabilities in Terminals&Sets** programming.

Direct-dial #: A digit used system-wide to call the Direct-dial telephone. The digit is assigned under **Access codes in Sys PRGMMNG**.

Direct-dial number: The digit used to call the direct-dial telephone.

Direct Inward Dial trunk: Trunks that allow direct inward dialing from the public network to the Norstar system.

Direct inward system access (DISA): The feature that allows remote users to dial directly into the Norstar system and use Norstar features. Callers will hear stuttered dial tone and will be required to enter a Class of Service password to gain access to the system. See Remote Access.

directed pickup: See Call Pickup Directed.

Directory number (DN): A unique number that is automatically assigned to each telephone or data terminal. The DN, also referred to as an internal number, is often used to identify a telephone when settings are assigned during programming.

Default DN assignments start at 221.

DISA DN: The received number assigned to the Norstar direct inward system access facility. If a caller dials a number that is assigned to the DISA DN, the caller hears stuttered dial tone and must enter a Class of Service password. Once the password is accepted, the caller hears system dial tone and can use Remote Access features. See Remote Access.

Disconnect Supervision: A setting that enables the Norstar system to detect if an external caller hangs up. Once an external caller hangs up, the Norstar system can disconnect its line. **Disconnect Supervision** is enabled under **Trunk/Line** data in **Lines** programming.

display: A liquid crystal display (LCD) on the telephone that guides you through feature operation and programming.

display button: The Norstar M7310 telephone and M7324 telephone and the Business Series Terminal T7316 are each equipped with three buttons located directly beneath the display. During feature operation or programming, some or all of these buttons may be used to provide further options. If an option is available, it is shown in the bottom row of the two-row display, directly above the corresponding display button. Display buttons are represented in this manual as underlined capital, such as OK.

Distinctive ring: Lines, telephones, and hunt group DNs can be configured with a distinctive ring that also determines the priority of a call.

DN: See Directory number.

Do Not Disturb: D N D

A feature that stops calls from ringing at your telephone. Only Priority Calls will ring at your telephone. A line button will flash when you receive a call, but the call will not ring.

DTMF: See Dual tone multifrequency.

dual tone multifrequency: Two distinct telephone signaling tones used for dialing.

DTI: See Digital Trunk Interface.

E

E&M/DISA Trunk Cartridge: The Trunk Cartridge that allows you to connect E&M trunks to the Norstar system. The E&M Trunk Cartridge also allows DISA access to the system by providing DTMF receivers for auto-answer trunks.

Emergency 911 dialing: The capability to access a public emergency response system by dialing the digits 9-1-1. State and local requirements for support of Emergency 911 Dialing service by Customer Premises Equipment vary. Consult your local telecommunications service provider regarding compliance with applicable laws and regulations.

emergency telephone: A single-line telephone, also referred to as a 500/2500 telephone, that becomes active when there is no power to the ICS.

evening schedule: See Schedules, and Services.

event message: Event messages are stored in the system log and displayed during a Maintenance session. They record a variety of events and activities in the Norstar system.

exceptions: See Overrides.

Expansion Cartridge: A cartridge that allows you to connect Trunk Modules and Station Modules to the ICS to expand system capacity for trunks and telephones.

There are two Expansion Cartridges: a two-port Expansion Cartridge and a six-port Expansion Cartridge. (See also Combo Cartridge.)

external call: A call to a destination outside the Norstar system.

External Call Forward: See Line Redirection.

external code: The number you dial to get an external line. By default it is 9, but this can be changed under **ACCESS CODES** in **SYS PROGRAMMNG**. You do not always need an external code. It is primarily to support the M7100 and T7100 telephones, and single-line telephones using an Analog Terminal Adapter.

external line: A line on your system telephone used for making calls to destinations outside the Norstar system.

external music source: See Music source.



external paging: A feature you can use to make voice announcements over an externally-mounted loudspeaker connected to the ICS. The external speaker is not a Norstar component and must be supplied by the customer.

F

feature button: Many Norstar features are invoked by pressing the Feature () button followed by a feature code. The feature button is also used to exit a feature.

Feature Cartridge: A replaceable cartridge containing the Norstar features. The Feature Cartridge is inserted into the ICS.

feature code: A number that is used to activate a particular feature.

Feature programming:   
Allows you to program a feature code onto a memory button.

Forward: See Call Forward.

Full Autohold (on idle line): When this feature is on, if you select an available line and then do something that selects another line, the first line is put on hold. Full Autohold is enabled under **Trunk/Line** data in **Lines** programming.

Full Handsfree: See Handsfree.

G

Ground Start trunk: Ground start trunks offer the same features as loop start trunks, but are used when the local service provider does not support disconnect supervision for the digital loop start trunks. By configuring lines as

ground start, the system will be able to recognize when a call is released at the far end. Ground start trunks are provided only by a DTI.

Group Listening:    

A feature that allows you to have others in your office hear a caller through your telephone speaker. The caller hears you only when you speak into the receiver. They cannot hear other people in the office.

You can cancel Group Listen for the current call. Group Listen is cancelled automatically when you hang up the Group Listen call.

H

Handsfree:

A feature you can use to make calls without using the telephone receiver. Full Handsfree is activated under **Capabilities** in **Terminals&Sets** programming. When it is activated, a Handsfree/Mute button is automatically assigned to the telephone.

Handsfree (HF) Answerback:

When activated, this feature automatically turns on the microphone at a telephone receiving a Voice Call so that the person receiving the call can respond without lifting the receiver. It is activated under **Capabilities** in **Terminals&Sets** programming.

Handsfree/Mute button: See Handsfree.

Hardware: A section in programming that shows what equipment has been installed in the ICS. This section is accessed by the installer.

headset: A head-mounted or ear-mounted telephone receiver that is used instead of the hand-held receiver. Headsets are not Norstar components and must be supplied by the customer.

Held (Line) Reminder: A system telephone rings and displays the message **On hold: LINENAM** when an external call has been placed on hold for a certain period of time. The **Held Line Reminder** feature and **Remind delay** are set under **Feature settings** in **System Programming**.

HF Answerback: See Handsfree Answerback.

Hold button: 

This button is used to suspend calls so that the person using the telephone can perform another task without disconnecting the caller.

Hook Switch Flash: See Link time.

Host system signaling: (Also referred to as end-to-end signaling.) System telephones can access a remote system or dial a number on an alternate carrier by means of host feature activation, such as Link, Pause and Run/Stop.

Hospitality The Hospitality features allow business which use hospitality telephones, or room-based telephones, to control access, alarms, and maintenance duties through the telephones.

Hotline: This feature automatically calls a pre-assigned number when the telephone receiver is lifted or the Handsfree/Mute button is pressed. A Hotline number can be an internal or external number. Hotline is assigned under **Capabilities** in **Terminals&Sets** programming.

Hunt group: The hunt groups feature allows a group of sets to be called by a single directory number ensuring that calls are easily routed to the appropriate group.

I

I/C: An abbreviation of intercom.

ICS (integrated communication system): The central hardware component in the Norstar system. The ICS has its own processor and memory, and provides a physical point of connection for the various types of devices, telephones, and expansion modules used in Norstar.

The ICS can function on its own as a basic system (with 32 system telephones and up to 48 external lines), or with the addition of Trunk Modules (TM) that supports more external lines, or Station Modules (SM) that support more system telephones.

Installer password: A one-to six-digit password that prevents unauthorized access to programming. The Installer password can be assigned and changed in **Passwords** programming.

Integrated Services Digital Network (ISDN): A digital telephone service that allows for a combination voice and data connection over a single, high-speed connection. ISDN service can operate over the same copper twisted-pair telephone line as analog telephone service.

intercom button: A button that provides access to internal lines used for calls within a Norstar system and access to external lines through a line pool or external code. A telephone may be assigned zero to eight Intercom buttons. This is done under **Line access** in **Terminals&Sets** programming.

intercom keys: See Intercom button.

internal line: A line on your telephone dedicated to making calls to destinations inside your Norstar system. An internal line may still connect you with an external caller if you use it to access a

line pool or to pick up a call using Norstar call handling features such as Call Park or Call Pickup Directed.

internal number: A number, also referred to as a Directory Number or DN, that identifies a Norstar telephone or device.

internal user: Someone using a system telephone within a Norstar system.

ISDN: See integrated services digital network.

ISDN DN: A directory number (DN) used by ISDN terminal equipment connected to the ICS. The system uses a maximum of thirty ISDN DNs.

ISDN Call Connection Limitation (ICCL) This feature piggybacks on the call initiation request and acts as a check at transit PBX points to prevent misconfigured routes or calls with errors from blocking channels.

K

Key service unit (KSU): See ICS.

L

Last Number Redial:   5

A feature that allows you to redial the last external number you dialed.

Fixed line:



A telecommunications line between two service points leased from a communications carrier for private use, usually incurring a monthly service rate. Fixed lines setting is used solely by data modules.

Least cost routing: See Routing service.

line: The complete path of a voice or data connection between one telephone (or other device) and another.

Lines: A programming section that allows you to assign settings to each trunk and external line. Lines programming can be done by an Installer or a System Coordinator Plus. A System Coordinator can program the name of a line.

Line number: A number that identifies an external line. The total number of lines depends on how many Trunk Modules are installed.



Line Pool:   6  4

A group of lines used for making external calls. Line pools provide an efficient way of giving a telephone access to external lines without taking up many line buttons. A line is assigned to be part of a line pool under **Trunk/Line** data in **Lines** programming.

Line Redirection:   8  4

A feature that allows you to redirect all calls on an incoming line to a destination outside the Norstar system. Once a line is redirected it cannot be answered within the Norstar system. The system may be set up to give a brief ring when a call comes in on a redirected line, under **Capabilities** in **Terminals&Sets** programming.

This feature differs from Call Forward in two ways: It redirects only external calls, not internal calls, and it redirects calls to destinations outside the system. Call forward redirects calls only to destinations inside the Norstar system. See Call Forward.

Link:   7  1

If your Norstar system is connected to a Private Branch Exchange (PBX), you can use a Link signal to access special features. The Link signal can also be included as part of a longer stored sequence on an External Autodial button or in a Speed Dial code. The Link symbol () uses two of the 24 spaces in a dialing sequence.

Long Tones: ☎ 8 0 8

A feature that allows you to control the length of a tone so that you can signal devices such as fax or answering machines which require tones longer than the standard 120 milliseconds.

Loop Start Trunk Cartridge: The Trunk Cartridge that allows you to connect loop start trunks to the Norstar system.

Lunch schedule: See Schedules, and Services.

M

M7000 telephone: This telephone has a no display. It does have four memory buttons. (Note this telephone is only supported on systems running Profile 2, 3, or 4).

M7100 telephone: A telephone with a single line display and one programmable memory button without an indicator.

M7208 telephone: A telephone with a single-line display and eight programmable memory buttons with indicators.

M7310 telephone: A telephone that has a two-line display, three display buttons, 10 programmable memory buttons with indicators, and 12 dual memory programmable buttons without indicators. An M7310 can be equipped with a Busy Lamp Field.

M7324 telephone: A telephone with a two-line display, three display buttons, and 24 programmable memory buttons with indicators. An M7324 telephone can be equipped with a CAP module.

Maintenance: A type of programming that is used to diagnose and repair problems in the Norstar system. Maintenance requires no programmable settings.

Malicious Caller ID (MCID) This feature is a European ETSI-based network feature that allows a user to use ☎ 8 9 7 record the caller information at the service provider.

memory buttons: Buttons that can be programmed to dial frequently used features or numbers automatically. See M7100/T7100, M7208/T7208, M7310, T7316, and M7324 telephone entries for their exact memory button configurations.

MCDN: Meridian Customer Defined Network is a PRI SL-1 protocol that allows Norstar systems on a network with a Meridian system to share some Meridian call features.

message: A feature that allows you to send a message to another Norstar user. The Message feature also allows you to know if you have any messages waiting and maintains a Message Waiting List to keep a record of your internal messages and your (external) voice mail messages.

Message Waiting Indicator: PRI lines can provide the signal that cause the set to display a message-waiting message, or light a lamp on the set to indicate a voice message. If your system is serviced by a remote voice mail system from a third-party vendor, the Meridian attendant telephone uses the MIC/MCK buttons to activate the MWI lamp on telephones at other sites.

Modular ICS NVRAM cartridge: A replaceable cartridge containing the Norstar features, commonly known as the Feature cartridge. The ICS NVRAM cartridge is inserted into the ICS.

Modular ICS ROM software cartridge: A PCMCIA cartridge containing the Norstar NA-MICS 4.0 features. The ICS ROM software cartridge is inserted into the Modular ICS NVRAM cartridge.

Module: A component of the Norstar 0X32 key system. Includes the Integrated Communication System, Trunk Module and Station Module.

Module status: A heading in **Maintenance** programming that shows what types of Trunk Cartridges are connected and whether they're busy, disabled, or malfunctioning.

Move Line buttons:

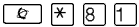

A feature that allows you to move assigned lines to different buttons (with indicators) on your telephone.

Music source: A radio or other source of music can be connected to the Integrated Communication System to provide music for the Music on Hold and Background Music features. A music source is not part of the Norstar system and must be supplied by the customer.

N

Names: Names can be assigned to System Speed Dial numbers, external lines, telephones, and service schedules. This is done in programming. You can use up to 16 characters to name a System Speed Dial number, and seven characters to name a telephone, line, or schedule. If a Name has not been assigned, the line number or DN will appear on the display instead of a name.

Network Call Diversion (NCD)

Norstar Network Call Diversion (NCD) is a network function that allows forwarding and redirection of calls outside the Norstar network when using an ETSI ISDN line. Functionality is similar to that of External Call Forward (ECF).

Network DN: A number supplied by the ISDN network service provider for ISDN terminal equipment.

Night schedule: See Schedules, and Services.

NT1 (Network termination type 1): A device used to connect the U interface of a service provider and the S or T interface (customer equipment). The Modular ICS can act as an NT1 when equipped with a BRI-U2 or BRI-U4 Card.

O

On hold: A setting, programmed under **Feature settings** in **Sys Programming**, that controls whether external callers hear music, periodic tones, or silence when they are placed on hold.

OPS: Off premise station.

OPX: Off premise set.

overlay: See Programming overlay.

overflow: A setting in **Routing Service** that allows users to decide what path an outgoing call will take if all the lines used in a particular route are in use when the call is made.

Overrides: One component of a restriction filter. Overrides are numbers you can dial even if they are forbidden by a more general restriction. See Restrictions.

P

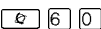
Page: 

A feature you can use to make announcements over the Norstar system. You can make page announcements over the telephone speakers and/or external speakers.

Page Time out: A setting that controls how long a Page Announcement can last. It can be assigned under **Feature settings** in **Sys Programming**.

Page zone: An area in the office that receives internal page announcements independently of the rest of the office.

Each page zone is identified by a number. Telephones are assigned to page zones under **Capabilities** in **Terminals&Sets** programming.

Park prefix: See Call park prefix.

Park timeout: The time before an unanswered parked call is routed back to the telephone that parked it. **Park timeout** is configured under **Feature settings** in **Sys Prgrmmng**.

Password: A password is a specific sequence of digits that you enter to gain access to Norstar programming, to override dialing restrictions, or to use remote access with DISA.

Passwords: A programming section that allows you to assign or change COS passwords, Call log passwords, or any of the programming passwords. Under **Passwords** programming, you can only modify the passwords for your level of programming.

Pause:

A feature that enters a 1.5-second delay in a dialing sequence on an external line. This is often required for signaling remote devices, such as answering machines, or when reaching through to PBX features or host systems. The Pause symbol (Ⓢ) uses one of the 24 spaces in a dialing sequence. For pulse dialing, inserts a 1.5 second pause into the dialing sequence.

PBX: private branch exchange.

Pickup Group:

A telephone can be placed into one of nine call pickup groups. A call ringing at a telephone within a pickup group can be picked up at any other telephone within the same pickup group. A

telephone is assigned to a pickup group under **Capabilities** in **Terminals&Sets** programming.

Pool: See Line pool.

portable telephone: See Companion portable telephone

Pre-dial: A feature that allows you to enter a number and check it on your telephone display before it is actually dialed. If the number is incorrect, you can edit it. The number is dialed only when you pick up the receiver or select a line.

Primary Rate Interface (PRI): An ISDN interface which uses 23 B channels and a D channel (23B+D).

Prime line: The line on your telephone that is automatically selected when you lift the receiver, press the Handsfree/Mute button or use an external dialing feature.

A **Prime Line** is assigned to a telephone under **Line** access in **Terminals&Sets** programming.

Prime Set (prime telephone): A telephone that provides backup answering for incoming calls on external lines. The prime telephone for a line will ring for any unanswered calls on that line. A prime telephone is assigned to a line under **Trunk/Line** data in **Lines** programming.

Priority Call:

If you get a busy signal when you call someone in your office, you can interrupt them for an urgent call. This feature is enabled for a telephone under **Capabilities** in **Terminals&Sets** programming.

Privacy: This feature determines whether a Norstar user may select a line in use at another telephone and join an established call. **Privacy** is enabled

under **Trunk/Line** data in **Lines** programming, but can be turned on and off by users during individual calls.

Private line: See **Private** to.

Private network: A telephone network consisting of owned or leased telephone lines used to connect different offices of an organization independently of the public network.

Private Network Identifier (PNI) this is an identifying digit or set of digits assigned to each system in a private network with a Meridian system. These codes are provided by the Meridian system administrator when the node is brought on to the network.

Private to: Allows you to select the telephone that will use the line exclusively. The line cannot appear on any other telephone, except the prime telephone for that line. Private lines cannot be placed into line pools.

Private lines are assigned under **Trunk/Line** data in **Lines** programming.

Programmed release:



A feature that performs the function of the  button in a programmed dialing sequence.

programming: Setting the way the Norstar system will work. Programming includes system-wide settings and individual telephone and line settings.

programming overlay: A paper template that is placed over the four memory buttons with indicators on the M7310, T7316 or M7324 telephone during programming. The overlay labels indicate the special function that each of the four buttons takes on in programming.

public line: An external line that can be assigned to any telephone and to many telephones. A line is assigned as **Public** under **Trunk/Line** data in **Lines** programming.

public network: The regular telephone network that connects most homes and businesses.

Public Safety Answering Point (PSAP): This is the first point of contact a caller reaches after dialing 911.

pulse/tone dialing: An external line setting for pulse or tone dialing. Pulse is the traditional method of dialing used by rotary-dial or push- button single-line telephones. Tone dialing allows telephones to communicate with other devices such as answering machines. Tone dialing is required to access the features that PBX systems may offer or to use another Norstar system remotely.

R

recall: See **Link** time.

receiver: The handset of a telephone.

receiver card: An abbreviated list of system feature codes that is stored under the telephone receiver. The card is found on a perforated sheet that comes with a system telephone.

Regression Code: Restores the previous system security number so that previously applied UTAM Activation Codes and Portable Credit Codes can be reentered to restore full system operation. Also required in cases of system recovery. This code cannot be reused.

Remind delay: A feature that causes a telephone to beep and display the message **On hold: LINENAM** when a call has been on hold for a programmable period of time. This period is the **Remind** delay.

Remote access: The ability to dial into a Norstar system from outside the system and make use of selected Norstar features. The lines, features, and dialing capabilities available to a remote user are determined by the Class of Service. If the remote access line is answered with DISA, the user must enter a Class of Service password to gain access to the Norstar system features.

remote access dial restriction:
See Remote restriction.

Remote capability: A subset of Norstar features that are available to users connected through remote access.

Remote monitoring: A feature that allows an off-site technician with a PC call in and troubleshoot your system through the built-in modem.

Remote paging: This feature allows remote users to use the Norstar paging feature. Access to this feature is governed by the Class of Service for the call. See Remote Access and Class of Service.

Remote restriction: A restriction filter applied to a line in order to control which digits can be dialed during an incoming remote access call. It is the equivalent of a set filter for a remote user.

remote user: Someone who calls into a Norstar system from a telephone outside that system and uses Norstar features or lines. See Remote Access.

Restriction filter: Through a combination of restrictions and overrides, restriction filters prevent certain telephone numbers or feature codes from being dialed. Restriction filters can be applied to lines, sets, specific lines on a set, and to Class of Service passwords. The Norstar system can handle up to 100 restriction filters.

Restriction service: A Services section that allows you to assign alternate dialing filters to lines, telephones, lines on a particular telephone, and alternate remote filters to lines at specified times of the day and on specified days.

restrictions: One component of a Dialing filter. Restrictions are numbers you cannot dial when that dialing filter is in effect. See Exceptions.

Ring Again:

A feature that can be used when you can't get through to someone on your Norstar system because their telephone is busy or there is no answer. Ring Again instructs the Norstar system to inform you when they hang up or next use their telephone.

ring group: A setting under Services that allows you to assign a number of different telephones to ring during one of the schedules. Up to 20 ring groups can be programmed by an installer or a system coordinator plus.

ring type:

A feature that allows you to select one of four distinctive rings for your telephone.

ring volume:

A feature that allows you to set the volume at which your telephone rings.

ringing service: A Services section that allows you to make additional telephones ring at specified times of the day and on specified days.

RIIs button: Ends a call in the same way that hanging up the receiver does. The Release button may also be used to end programming, Maintenance sessions, and feature operations.

Routing: See Routing service.

Routing service: A programming section that allows outgoing calls to be directed automatically based on the numbers a caller dials. For Norstar

systems linked in a network, routing can create a transparent or coordinated dialing plan. It can also be used to direct calls to the least expensive lines according to a Services schedule (sometimes called least cost routing).

Run/Stop:  *  9

A feature that creates a break point in a programmed external dialing sequence. When you press a programmed key, the system dials the number up to the run/stop. When you press it again, the system dials the digits following the run/stop.

S

S loop: A type of loop provided by a BRI-ST Card. It connects the ICS to ISDN terminal equipment which uses an S interface.

SAPS: See station auxiliary power supply.

Saved Number Redial:    7

A feature that allows you to save the number of the external call you are on (providing you dialed the call) so that you can call it again later.

Schedules: Any of six different sets of services that can be applied to your Norstar system. A schedule can be activated manually from a control telephone or activated automatically at specified times. See also Services.

Selective line redirection: See Line Redirection.

Service modes See Services.

Service Profile Identifier: See SPID.

Services: A programming section that allows you to assign which telephones ring, which restrictions apply, and which call routing is used during any of six different schedules. There are three services: Ringing

service, Restriction service and Routing service, all found in Services programming.

set: A telephone.





Set Copy: A programming section that allows you to copy programmable settings from one telephone to another of the same type. Set Copy provides two options: duplicating System Data and User Data, or duplicating System Data only. Set Copy does not provide the same copy capability as **COPY**, which is more selective of the settings that can be duplicated.

Set filter: See Restriction filter.

Set lock (telephone lock): This feature allows you to limit the number of features that may be used or programmed at a telephone. Full set lock allows very few changes or features, Partial set lock allows some changes and features, and No set lock allows any change to be made and any feature to be used. Set lock is assigned under Capabilities in Terminals and Sets programming.

Set relocation: See Automatic Telephone Relocation.

shift button: A small triangular button beside the dual memory buttons on the upper half of the M7310 telephone. You press the shift button to store or access features on the top half of the dual memory buttons.

Show Time:    0  3

While on a call, accessing this feature allows you to see the current date and time on the Norstar telephone display.

Software keys: A programming section used to enable the optional Remote monitoring feature. One setting provides a System ID, which an installer or system coordinator plus then uses to request three password keys from the Nortel Customer Response Center.

Once these three passwords have been entered, the system will permit Remote monitoring.

SPID (Service Profile Identifier):

A number that identifies devices connected to an ISDN network. A device may have more than one SPID depending on the number of channels it uses. SPIDs may be used to identify terminal equipment to the ICS, or to the service provider.

Startup programming: When a Norstar system is first installed and powered up, Startup programming must be performed before any programming can be done. Startup initializes the system programming to defaults.

Station: An individual telephone or other Norstar device.

Station Auxiliary Power Supply (SAPS):

A device which provides power to a Norstar telephone that is connected more than 300 m (975 ft.) and less than 1200 m (3900 ft.) from the ICS, or to a CAP module.

Station Module: A module that allows you to connect up to 16 additional telephone to your Norstar system.

Station set test:

A series of diagnostic tests for these components of a Norstar telephone: display, buttons, handset, speaker, and power.

System coordinator: The person responsible for customizing the Norstar system through programming and for helping co-workers use the Norstar system.

System coordinator password: A one- to six-digit password that prevents unauthorized access to programming.

The System coordinator password can be assigned and changed in Passwords programming.

System coordinator plus: A system coordinator who also performs technical and maintenance functions for the Norstar system.

System coordinator plus

password: A one- to six-digit password that prevents unauthorized access to programming. The System coordinator plus password can be assigned and changed in Passwords programming.

System coordinator plus

programming: A combination of common and installer programming settings.

Press * * , then to access System coordinator plus programming.

System coordinator

programming: The programming settings that are most commonly changed once the Norstar system is installed.

Press * * , then to access System coordinator programming.

system data: An option in the Set Copy function. System Data refers to the programmable system settings that apply to all telephones and lines.

System programming: A programming section that allows you to assign and maintain certain settings on the Norstar system. System programming is performed by an installer or system coordinator plus.

System speed dial code: A three-digit code (001 to 255) that can be programmed to dial a telephone number up to 24 digits long. System speed dial codes are programmed for the entire Norstar system under the System Speed programming heading.

System Startup: See Startup programming.

System Startup access code: To begin System Startup, press **[*][*][S][T][A][R][T][U][P]**. An Installer password is required before Startup programming can begin.

System ID: The System ID (or System Security number) can be accessed on any programming telephone display by pressing **[*][*][S][Y][S][I][D]**, or **[*][*][7][9][7][4][3]**.

System-wide Call Appearance (SWCA) keys **[*][*][5][2][0]** to **[*][*][5][3][5]**. These 16 feature codes can be assigned to buttons with indicators on a group of telephones to provide call appearance for incoming calls that can be answered by any telephone in the group. At the same time, the indicator displays the current status of the call.

T

T1: Digital carrier system or line that carries data at 1.544 Mbps.

T7000 telephone This telephone has a no display. It does have four memory buttons. This telephone functions in the same way as the M7000 telephone. (Note this telephone is only supported on systems running Profile 2, 3, or 4).

T7100 Business Series Terminal: A telephone with a single line display and one programmable memory button without an indicator.

T7208 Business Series Terminal: A telephone with a single-line display and eight programmable memory buttons with indicators.

M7316 Business Series Terminal: A telephone that has a two-line display, three display buttons, 16 programmable memory buttons with indicators, and 12 memory programmable buttons without indicators.

T7406 telephone: This portable handset functions very similarly to the T7310 telephone. Functions and installation are all described in separate documentation specific to the telephone.

T loop: A type of loop provided by a BRI-ST Card. It connects the ICS to an ISDN network using an NT1.

Target lines: Lines used to answer incoming calls only. A target line routes a call according to digits it receives from an incoming trunk. They are referred to by line numbers in the same way as physical lines.

TE: See Terminal equipment.

TEI (Terminal Endpoint Identifier): A digit used to identify devices which are using an ISDN connection for D-channel packet service.

Telco features: A programming section that allows you to specify the external telephone numbers that are dialed by the Message feature to retrieve voice messages, or to set up CLASS (CMS) services for lines and sets. Telco features are accessed by an installer or a system coordinator plus.

Terminal Endpoint Identifier: See TEI.

Terminal equipment (TE): A generic term for devices that connect to an ISDN network. Examples of ISDN TE are ISDN telephones, computers equipped with ISDN cards and video terminals.

Terminals and Sets: A programming section that allows you to assign and change settings that apply to

the telephones and other devices connected to the Norstar system. Terminals and Sets programming is performed by an installer or a system coordinator.

Time and date: A programming section that allows you to manually change time or date. The time and date can also be changed by pressing and entering the Basic password or one of the programming passwords.

Transfer:

A feature that allows you to redirect a call to another telephone in your Norstar system, over a network or outside your Norstar system.

Transfer Callback: If a transferred call is not answered after a specific number of rings, the call will return to the telephone that made the transfer. The number of rings is assigned under Feature settings in System programming. Transfer Callback does not apply to calls transferred externally.

Trunk: The physical connection between the Norstar system and the outside world using either the public telephone system or a private network.

Trunk Answer:

A feature you can use to answer a call on any line that has an active Ringing service Service Mode, even if that line does not appear on your telephone. Trunk Answer is enabled in Services programming.

Trunk Anti-Tromboning (TAT):

This MCDN network feature is a call-reroute feature that works to find better routes during a transfer of an active call. This feature acts to prevent unnecessary tandeming and tromboning of trunks. This action occurs after the speech path has been established.

Trunk Module: A module that allows you to install additional Trunk Cartridges in your system to provide up to 12 additional trunks.

Trunk route optimization: (TRO)

This is a private network feature that provides routing for forwarded calls along the shortest or best route on the private network.

U

U interface: A two-wire ISDN interface used for both network connections and terminal connections to the ICS.

U-LT: A type of loop provided by a BRI-U2 or BRI-U4 Card. It connects the ICS to ISDN terminal equipment which uses a U interface.

Uniform Dialing Plan: (UDP) This type of dialing plan uses a location code to identify each node on a private network. Dialing sequence: (destination code)+(location code)+DN.

U-NT loop: A type of loop provided by a BRI-U2 or BRI-U4 Card. It connects the ICS to an ISDN network.

Unsupervised line: A line for which disconnect supervision is disabled. If an external caller hangs up, the Norstar system does not detect the disconnection and does not hang up its line. See Disconnect Supervision.

User Data: User Data is an option in the Set Copy feature. User Data refers to the personal settings that are unique to an individual telephone, and are not programmed for the system. User Data is programmed at each telephone.

These settings, for example, include user Speed Dial and the assignment of programmable memory buttons.

User Filter: See Restriction filter.

User Preferences: a programming section that allows you to assign autodialers, user speed dial codes, display contrast, and other settings to a specific telephone or person. You do not have to program these settings at the person's telephone. User preferences are assigned in Terminals and Sets programming.

User Speed Dial:

Three-digit codes (256-279) can be programmed to dial external telephone numbers. User Speed Dial numbers are programmed for each telephone, and can be used only at the telephone on which they are programmed.

V

Voice Call:

A feature you can use to make an announcement or begin a conversation through the speaker of another telephone in the Norstar system. The telephone you call will not ring. Instead, the person you call will hear a beep and then your voice. Their telephone will beep periodically to remind them that their microphone is open.

Voice Call deny:

A feature that prevents your telephone from receiving Voice Calls.

Voice message center: If you have subscribed to Call Display services you can receive visual Voice Message Waiting Indication, providing your telephone has a display. If you have Voice Message Waiting Indication, you can program the telephone numbers required to access up to five different Voice Message Centers. You can also program which of the five Centers is to be accessed by each specific line.

W

Wait for dial tone:

A feature that causes of sequence of numbers to pause until dial tone is present on the line before continuing to dial. The Wait for dial tone symbol () uses two of the 24 spaces in a dialing sequence. This feature requires a Services or Combo Cartridge.

wireless: See Companion.

Index

Symbols



**79743 (System ID) 293
**CONFIG (☎) **266344) 305
**DIALPAD (☎) **3425723) 300
**LINE 294
**PROFILE (☎) **7763453) 299
**SET (set programming) 294
**STARTUP (☎) **7827887) 301
**SYSID 293
**SYSID (☎) **79743) 453
**TIME (☎) **8463) 388
*7, Contrast Adjustment 549
1, message reply enh 408
811 Call Display 331
819 ONN blocking 432

Numerics

0X32

using old modules 199
1st display, programming 331
25-pair connector 225
2-way DID, PRI dialing plan 108
2-way service 109
900 CbC service
911, restrictions 324

A

absorb length, zero 374

access

controlling on a network 85
line pool programming 312
passwords for programming 278

access codes

auto DN 420
carrier codes 422
CDP 95
conflicts 95, 416
default codes 416
direct dial number
 system programming 419
DISA DN 421
external code 419

line pool 102
line pool and access code 424
line pool codes 417
listing 280
long distance 375
park prefix 418
private access code 421
programming 416
remote line access 423

access package, COS 85
access services, CbC services 433
adaptive, BRI sampling 475
administrative set, Hospitality services
 207
advanced private network, see APN and
 MCDN

AEM

cable connections 225
see also ASM

alarm

check active 536
check current 500
codes 506
CSU 536
network evt log 504
short term 537
system administration log 503
troubleshooting 510

Alarm 10 507, 510

Alarm 37 508

Alarm 37 510

Alarm 40 508, 510

Alarm 41 508, 510

Alarm 42 508, 510

Alarm 43 508, 510

Alarm 44 508, 510

Alarm 45 508, 510

Alarm 46 508, 510

Alarm 47 508, 510

Alarm 50-X 508, 510

Alarm 51-X 508, 511

Alarm 52-X-Y 509, 511

Alarm 61-X-Y 509, 511

Alarm 62-X-Y 509, 512

Alarm 63-Z 509, 512

- Alarm 68-Z 509, 513
- Alarm 75 513
- Alarm 76-X 509, 513
- alarm messages
 - programming alarm set 406
- alarm set
 - programming 406
- alarm telephone 218
- alarms
 - hospitality 441
 - Hospitality services 207
- allow last number redial 328
- allow redirect 318
- allow saved number redial 328
- alpha tagging
 - CLID match 409
- alternate call ringing 353
- analog
 - message reply enh 407
 - name and number blocking 432
 - trunk data settings 334
 - trunk type 335
- analog access lines (AAL) 461
- analog E&M trunks, private network 77
- analog network loss treatment 461
- analog station module
 - cable connections 225
 - connecting 224
 - message reply enh
 - see also analog extension module
- Analog Station Module, see ASM and AEM
- analog telephones, external code 419
- Analog Terminal Adapter, see ATA or ATA2
- analog trunk
 - E&M 77
 - see also loop start trunks 75
- analog trunk cartridge 214
- analog VSC
 - programming 449
- ANI
 - E&M and DID lines on DTI 346
 - programming number
 - Winkstart 346
- ANI number 334
- answer calls
 - SWCA lines 403
- answer DNs
 - Companion 314
 - programming 314
 - view 315
- answer keys
 - phantom DN 409
 - programming 408
 - setting features 408
- answer mode 334, 341
- answer timer 460
- answer with DISA 334, 342
- ANY key
 - destination codes 369
- APN
 - also see MCDN 121, 126
 - network features 111
 - networking features 110
 - using MCDN protocol
- appearance
 - auto privacy 340
 - DID lines, default numbering 310
 - DID target line 74
 - E&M trunk manual-answer 78
 - hunt group 390
 - loop start trunk, manual answer 75
 - message waiting indication 331
 - network route 104
 - trunks 72
 - using internal line for private call 162
- appearances
 - setting SWCA controls 403
 - SWCA keys 403
- applying template 279
- appr only 147, 152, 309, 315, 390
- appr&ring 147, 152, 309, 315, 390
- ascending mode, service provider 109
- ascending, B-channel sequence 458
- ASM
 - analog station module 466
 - see also AEM
 - verifying status 466
- assign
 - answer DNs 314
 - CAP lines 311
 - intercom buttons 314
 - line pools 312
 - lines 309
 - prime line 313
- assigned lines, viewing 311

assigned, BRI DNs 476

ATA

- accessing external lines 419
- answer timer 319
- device 320
- for OPX applications 266
- optional equipment list
- programming 320
- settings 318
- troubleshooting 562
- use 320

attn attempts 441

Attn duration 441

auto associate, SWCA 403

auto attendant, bypassing

auto DN

- access codes 74
- conflicts 339, 367, 420
- DID trunk 83
- PRI trunk 83
- private network auto-answer 83
- programming 420
- rec'd number length 420
- received number length 426

auto number identification, see ANI

auto privacy 334

- F83 340
- programming 340

Auto time&Date

- programming 402

auto-answer

- answer with DISA 342
- BRI trunks 309
- DID 73
- disconnect supervision 341
- E&M trunks 77
- E&M/DISA 76
- loop start trunk and DISA 75
- loop start trunks 75
- no DISA 75
- private network 83
- remote access 82
- remote access trunks 81
- remote restrictions 352
- restriction filters 82
- trunks, DISA 89

autodial, network calls 104

automatic ongoing line selection 337

automatic route selection, see routing

automatic telephone relocation

- programming 267

Automatic Time and Date 402

auxiliary equipment

- wiring chart 245

auxiliary ringer 271

- call transfer 343
- maximum voltage 271
- optional equipment list 181
- programming 343, 360
- Terminals&Sets 318
- troubleshooting 564
- trunk type data 334

available, BRI DNs 476

B

B1 and B2 directory numbers 241, 242–243

back 285

backboard 216

background music

- installation 271
- programming 272, 397
- troubleshooting 564

backspace (bksp) button 286

back-to-back cross-connections 257

backup

- maintaining records 195

backup, NRU 363

basic

- answer key 408
- hospitality 440

basic password

- description 278
- programming the password 386

basic programming

- common changes 307

Basic Rate Interface, see BRI, see also ISDN

B-channels

- BRI card 472
- port numbering 241
- programming static DID 2-way
- service 109
- sequence, PRI 458

BchanSeq 458

BchnSeq mode, static DID and two-way

- DID 109

- Bellcore standard 212
- Bellcore/National ISDN Users Forum (NIUF) 57
- BLF, M7310 only
- bracket 215
- break-in, MCDN 143
- BRI
 - answer mode 341
 - assign DNs 476
 - assign lines/loops 309
 - assigning SPIDs to T and NT loops 472
 - becoming a clock source 477
 - BRI-ST cartridge wiring 262
 - BRI-U wiring 250
 - call type 473
 - card 48—53, 471—476
 - card programming 471
 - cards 249
 - clock source loops, power up or down 478
 - DNs on loop 475
 - D-packet service 474
 - handling calls 63
 - internet connection 67
 - lines on T/NT loop 471
 - lines pooled 63
 - loop DN 476
 - loop type on card 471
 - loopback test 532
 - loops on card 471
 - LT loop (Lp) 474
 - name and number blocking 432
 - network DNs 473
 - network loop programming 69
 - network name display supporting protocols 429
 - network wiring 252
 - number of B-channels 472
 - ONN blocking 450
 - POSTA 69
 - profile support 297, 298
 - programming lines 63
 - programming VSC 449
 - SPID 309
 - ST card 214
 - ST card wiring 249
 - T network wiring 252
 - target line, if busy 339
 - TEIs 474
 - terminal equipment 65
 - test network connection 211
 - trunk 79
 - trunk data settings 334
 - trunk module locations 467
 - trunk type 335
 - U2 card 214
 - U4 card 214
 - U-NT network wiring 252
 - view card 456
- BRI (Basic Rate Interface)
 - U2 trunk modules 218
 - U4 trunk modules 218
- BRI, see also ISDN
- bridge taps 187
- BRI-ST
 - terminating resistors 222
 - trunk modules 243
- BRI-U2, trunk modules 243
- BRI-U4, trunk modules 243
- broadcast
 - hunt groups 393
 - ILG upgrade to Hunt Groups 206
- broadcast ring 309
- business name
 - network name display 431
 - programming 429
- BusName, see business name and call display
- BUSY 492
- busy
 - busy tone 395
 - lines, hunt groups 395
 - overflow set, hunt groups 396
 - routes, overflow routing 379
- busy lamp field, see BLF
- button prgrming 289, 321
- buttons
 - Feature 282
 - handsfree 282
 - Hold 282
 - programming button definitions 285
 - programming telephones 282
 - Release 282
 - volume control 282

C

- cable trough 225, 232, 274
- cadence, service tone 589
- call attendant, SL-1 network
- call blocking, ONN programming 432
- call by call
 - card settings 458
 - PRI limits 437
 - programming 435
 - programming PRI limits 437
 - programming service selection 436
 - protocols referenced with services 435
 - routing map table 459
 - routing table 365
 - routing, all 459
 - routing, incoming calls 458
 - routing, none 459
 - service selection for PRI 433
 - services, supporting protocols 433
 - supported services 433
 - usage metrics 542
- Call by Call, see also CbC
- call descriptions, public network 155
- call disconnect, OSI 341
- Call Display
 - programming 330
 - using CLASS assignment 330
- call display
 - ANI number 346
 - CI trunk cartridge 214
 - order of display 331
 - outgoing call 316
 - services, customizing 330
- call diversion
 - networks 166
- call forward, hunt groups 390
- call information feature 332
- call information trunk cartridges
 - loop start signaling 76
- call log
 - call log opt'ns 321
 - call log pswrds 280
 - information, power fail 276
 - password 384
 - resetting 405
 - space 332
 - space, available spaces 405
- call park prefix, conflicts 367
- call pickup, message answer enh 407
- call restriction
 - hospitality services 440
 - line restrictions 350
 - programming filters 322
 - users 349
- call routing
 - between switches 104
 - carrier codes 125
 - CDP 95, 131
 - CDP, Public DN 94
 - dialing plan
 - description 94
 - E&M dialing plans 97
 - external routing code 106
 - hunt groups 389
 - incoming DID calls 106
 - internal DID calls 106
 - prime set overflow 340
 - private network, routing codes 121
 - programming CbC services 436
 - Public DNs 124
 - restriction filters 103
 - setting up access code table 96
 - tandem networks 119
 - UDP 128
 - using E&M trunks 162
- call setup, ISDN and OLI 315
- call transfer, auxiliary ringer 343
- call type, BRI card 473
- call usage, monitoring set 72
- call waiting indications, see also CWI
- call, using destination codes 376
- called ID
 - network name display 430, 431
 - programming 332
- called number, OLI 315
- Called Party Number, see CDN
- caller features
 - through private network 93
 - through public network 92
 - within system 92
- Caller ID set 330
- caller ID, see call display services
- caller identification, ANI number 346
- caller information, see also CID 111
- calling party, BusName, programming 429

- callog opt'ns 289
- camp timeout, programming 398
- camp-on
 - MCDN 142
- CAP
 - features 411
 - line assignment 311
 - line keys 310
 - M7324 telephone
 - moving a set 412
 - programming 411
 - programming assignment 411
- capabilities
 - listing 280
 - programming 317
- card
 - answer timer 460
 - CO fail 460
 - edge loopback test 527
 - I/F levels 461
- cards on ICS 455
- cards on KSU
 - listing 280
 - show module 455, 456
- carrier access code
 - branded outwat calls 365
 - conflicts 422
 - description 125
 - programming 422
- carrier failure
 - alarms 533
 - standard 460
- Carrier Identification Code (CIC) 422
- cartridge
 - checking the state 497
 - E&M Trunk 185
 - enabling 498
 - enabling/disabling 467
 - inserting 221
 - installation 213
 - installation tips 217
 - loop start trunk 185
- cause code 438
- CbC
 - destination codes 362
 - dialing plan 106
 - incoming routing for DISA 64
 - network 104
 - Private DN over Tie 106
 - requirements, no CbC 105
 - see also call by call
 - service options 459
- CCI, emergency transfer conditions
- CCITT 278
- CDN
 - DISA
 - service types 64
 - Target Line Receive Digit Length 64
- CDP
 - access codes 95
 - call routing 95, 131
 - call scenarios 131
 - dialing plan features 412
 - dialing sequence 95
 - dialing string 130
 - DN range 130
 - DNs 94
 - overview 94
 - public DN 94
 - SL-1 network features
- CE logo 23
- central answering position, see CAP
- central office, ANI/DNIS service 346
- change DN type 280
- change DNs 244, 280
- change, button 286
- changing DNs 397
- Channel Service Unit, see CSU, CSU
 - internal
- channel, disabling PRI 524
- charts, wiring 241
- checking the system version 487
- CI trunk cartridge
 - installing 214
 - wiring chart 256
- CIC (Carrier Identification Code) 422
- Class of Service password, see COS
- CLASS trunks 402
- clear line data 456
- CLI, programming in pools 316
- CLID
 - CLID match for alpha tagging 409
 - CLID match 409
 - CLID set
 - network name display 431
- clock
 - automatic date and time 402

- hospitality, setting time 440
- clock source
 - becoming a source 477
 - description 476
 - network clock settings 478
 - primary reference 477
 - programming 481
 - sample configurations 478—481
 - secondary reference 477
 - timing master 477
- clocking cartridge 52
- ClockSrc 464
- CO fail, TI and PRI 460
- combo cartridg, installation planning 180
- common dialing plan 110
- common settings
 - list 280
 - programming 381
- Companion
 - answer DN 314
 - changing DNs 425
 - equipment list 181
 - expansion module numbering 243
 - hunt group 390
 - installing base stations 274
 - interface headings 280
 - listing 280
 - programming registration password 386
 - services cartridges 181
 - software key 452
 - supported 31
 - UTAM, upgrading 196
- cond pswd, programming 387
- configuration programming, default
 - access codes 417
- conflicts 427
- connect wiring 237
- connected name, network name display 430
- connection
 - expansion modules 224, 239
 - stand alone 54
- contact, external paging 273
- continuity loopback test 528, 531
- control circuit interface, see CCI
- control set
 - activating services 353
 - assigning to lines and sets 354
 - programming 354
 - schedules 355
- controlling schedules 358
- coordinated dialing plan, see CDP
- coordinator, system password 277
- copy
 - COS password 382
 - display button 286
 - list of copy/not copy 292
 - remote access packages 424
 - set programming 290, 308
 - single, range, all 290
 - system data 290
 - telco features 330
 - to a group of telephones, not part of a range 291
 - to a range of telephones 290
 - to a single telephone 290
 - trunk/line data 335
 - user data 290
- COS
 - auto DN 420
 - auto-answer E&M trunk 78
 - auto-answer system 82
 - auto-answer, no DISA 75
 - calls answered with DISA 421
 - changing 85
 - copy 382
 - dialing capabilities 81
 - dialing filters 85
 - incoming remote call 85
 - line filter 383
 - maximum 382
 - network 85
 - password 74, 76
 - programming 382
 - programming tips 382
 - public call 156
 - remote access package 423
 - remote access with DISA 82
 - remote pkg 384
 - restrictions 74
 - security 85
 - user filter 383
 - with DISA 89
- credit card verification 68
- cross connections, E&M/DISA trunk cartridge 258
- CSU

- alarms 536
- clock source 464
- connecting DTI to external 254
- disabling internal CSU 237
- line build 463
- line coding 464
- listing 280
- performance statistics 534
- stats 485, 533
- turning off/on, disable trunk 462
- customizing call display services 330
- CWI, SL-1 network
- cycle, park mode 399

D

- data copied 292
- Data Module 483
- data modules, connecting 224
- data not copied 292
- data, call type 473
- date and time, see AutoTime&Date
- Daylight Savings Time, see daylight time
- daylight time, programming 402
- D-channel packet
 - service 69
 - service, see ISDN
 - TEIs 474
- DDD, message reply enh, analog sets 408
- D-Dial 317
- debit machines 68
- default destination codes
 - MICS 368
- default password
 - basic 307
 - system coordinator 307
 - system coordinator plus 306
- default programming, returning to 275
- defaults
 - basic password 386
 - changing 304
 - dialing restriction 324
 - DN lengths 427
 - filters, cold start 325
 - Installer password 385
 - line numbers 468
 - remote access packages 424
 - restrictions 324

- set restrictions 327
- System Coordinator password 386
- System Coordinator Plus password 386
- delay
 - by number of rings 291
 - camp timeout 398
 - dial signal type 345
 - DRT 400
 - held line reminder 401
 - park timeout 399
 - transfer callback 399
- delayed ring transfer
 - hunt groups 392
 - programming 400
- delayed ring transfer to prime, see also DRT
- deprovisioning a line 524
- descending mode 109
- descending, B-channel sequence 458
- desk information, hospitality 439
- desk pswd 387
- desktop conferencing 173
- destination codes
 - conflicts 303, 339, 367, 418, 419, 420, 421
 - defaults for MICS 368
 - description 363, 367
 - digit absorption 370
 - E&M dialing plan 97
 - network 96
 - normal rte 370
 - numbering 96
 - using 74
 - using to make a call 376
 - wild card 368
 - wild cards 369
- device
 - disabling 492
 - enabling 493
 - state 492
- diagnostics
 - release reasons 438
 - T1 signal 533
 - test results, system test log 499
- dial mode 334, 338
- dial tone, absent on external lines 554
- dialed digits
 - CLID match 409

- DID trunk 83
 - host delay 406
 - PRI trunk, matching DNs 83
- dialed number identification, see DNIS number
- dialing
 - CDP call scenarios 131
 - filter, E&M trunk 88
 - filter, remote 87
 - line restrictions 350
 - restriction filters 86
 - restriction for remote callers 351
 - UDP call scenarios 127
 - unified dialing plan with line pools 338
- dialing opt'ns 289, 321
- dialing plan
 - 2-way DID 108
 - CbC configuration 106
 - CDP 94
 - enbloc dialing 412
 - listing 280
 - network 413
 - prefix 415
 - PRI routing table 366
 - programming 412
 - public DNs 415
 - public network 415
 - shared line pools 102
 - transparent 94
 - UDP 95, 414
 - using E&M lines 97
 - using line pools 338
 - using public lines 96
- dialing plans 94
- dialing restriction
 - allocated overrides 325
 - defaults 324
 - filters 350
 - line filter 383
 - line/set restriction 329
 - maximum length 325
 - maximum number 325
 - maximum restrictions and overrides 325
 - remote user 352
 - removing a filter 325
 - set restrictions 327
 - user filter, COS 383
 - wild card character 323, 368
- dialing rules
 - interdigit timeout 416
 - private DN length 415
 - private network ID 414
- dialing sequence
 - digit absorption, destination code 370
 - VSC 450
 - wild card 325
- dialing sequence restrictions 322
- dialout
 - programming 364
 - use pool 364
- dialpad
 - entering numbers 288
 - installation checklist 178
 - password 278
 - programming 296, 300
 - programming headings 279
- DID
 - ANI number 346
 - auto DN 74
 - auto-answer only 73
 - default line numbering for target lines 310
 - DISA DN 74, 89
 - DTMF
 - emergency transfer 261
 - incoming 76
 - line numbers 468
 - line setting 337
 - no DISA 83
 - PRI lines 105, 308
 - prime line 313
 - private network features 83
 - remote access, DISA 81
 - restrictions 74
 - simultaneous calls 310
 - supervisory signaling 261
 - target line 74
 - target lines 71, 73
 - trunk 83
 - trunk cartridge 214
 - trunk cartridge wiring 259
 - trunk data settings 334
 - trunk description 73
 - trunks
 - DID template, target lines 80

- DID trunk
 - access codes allowed 74
 - no prime line 74
- digit absorb, destination codes 370
- digital
 - access lines 461
 - DTI wiring 254
 - interface, clock source 476
 - network loss treatment 461
 - T1 trunks, adding 199
- digital trunk
 - configurations 482, 483
 - Interface trunk, see DTI
- direct dial
 - intrnl/extrnl 410
 - line selection 410
 - programming 410
- direct dial digit
 - conflicts 303, 367, 418, 419, 427
 - programming, F1 408
- Direct dial extension 409
- direct dial set, extra-dial telephone 420
- Direct Inward Dial trunks, see DID trunks
- Direct Inward System Access, see DISA
- directd pickup 401
- direct-dial # 419
- direct-dial number
 - programming 419
- directory numbers
 - B1 and B2 241
 - changing 397
 - changing starting DN 302
 - conflicts 303
 - hunt groups 391
 - in a network 94
 - length 427
 - target line received number length 303
- DISA
 - accessing
 - auto DN 420
 - auto-answer no DISA 75
 - auto-answer trunks 75
 - Called Party Number (CDN) 64
 - calling name information 430
 - conflicts 367
 - DID trunk 83
 - DISA DN 64
 - disconnect supervision 341
 - DN 421
 - E&M network 97
 - E&M trunk cartridge 214
 - E&M trunks 78
 - loop start trunks 75
 - PRI trunk 83
 - private networks 156
 - programming answer with DISA 342
 - programming on PRI 64
 - remote access trunks 81
 - remote callers 89
 - trunk cartridge wiring 258
 - using 75
 - using COS password 89
 - wiring chart 257
- DISA DN
 - changing the COS password 85
 - conflicts 339, 421
 - DID trunk 74, 83
 - mapping to DID trunks 89
 - overriding filters 88
 - PRI trunk 83
 - private network auto-answer 83
 - public call 156
 - received number DN 426
 - received number length 421
 - using 74
- Disabled by sys 492, 497
- Disabled by user 492, 497
- Disabling 492, 497
- disabling
 - a device 492
 - a module 498
- disconnect OSI 341
- disconnect supervision
 - disconnect timer 460
 - loop start trunks 76, 82
 - programming trunk mode 341
 - T1 trunks 72
- disconnect time, hardware cards 460
- display buttons 285
- display cntrst 289, 321
- display unreadable, troubleshooting 550
- distribution block, see distribution panel
- distribution mode, hunt groups 393
- distribution panel, connecting the wiring 237
- DN hunting, see multi-line hunt





- DN length
 - at startup 303
 - conflicts 427
 - listing 280
 - programming 427
 - DND
 - CAP 411
 - leaving hunt group 390
 - on busy 317
 - DNIS number
 - programming
 - trunk/line data settings 334
 - Winkstart 346
 - DNs
 - assign to BRI card 476
 - BRI loop DN 476
 - BRI network DNs 473
 - changing 397
 - conflicts 418, 419
 - default ranges 425
 - defaults 417
 - DISA 421
 - entering in programming 288
 - hunt groups 391
 - ISDN 62
 - length 427
 - on loop, BRI card 475
 - private DN length 415
 - D-packet service
 - BRI card 474
 - LT loop 474
 - POSTA 68
 - POSTA for BRI 69
 - TEI and DN
 - DRT delay 400
 - DRT, programming 400
 - DTI
 - (T1) disconnect timer 460
 - B-channel sequence 458
 - card PRI firmware download 59
 - clock source 464, 476
 - configurations 482
 - connecting 237
 - connecting to external CSU 254
 - connecting to service provider 254
 - continuity loopback test 531
 - CSU line build 463
 - E&M network 97
 - framing 462
 - ground start trunk 72
 - internal CSU 463
 - LEDs 568
 - line numbers 468
 - loop start signaling 76
 - network clock settings 478
 - PRI 179
 - PRI software key 452
 - PRI support 65
 - primary reference 477
 - programming clock source 481
 - programming lines 337
 - secondary reference, clock source 477
 - selecting a PRI protocol 456
 - specifications 591
 - timing master, clock source 477
 - trunk 71, 214
 - trunk type, changing 335
 - wiring chart 254
 - DTMF
 - answer mode 342
 - dial mode 338
 - E&M line settings 337
 - on DISA 74
 - receivers 74, 185
 - dualtone multifrequency, see DTMF
- ## E
-
- ### E&M
- analog, private network 77
 - ANI number 346
 - answer mode 341
 - answer with DISA 342
 - auto- manual-answer 77
 - dialing plan 97
 - DISA 78
 - disconnect supervised 82
 - disconnect timer, on card 460
 - DNIS number 346
 - for target lines 80
 - full auto hold 344
 - gain level 347
 - line numbers 468
 - line pools 336
 - line setting 337
 - line settings 337
 - loop start requirements 76

- network requirements 97
- private network answer mode 342
- private network, no DISA 82
- profile support 297, 298
- remote access 81
- remote access, private network 82
- set filters 88
- single trunk to line pool 338
- trunk cartridge 185, 214
- trunk cartridge cross connections 258
- trunk cartridge wiring 258
- trunk cartridge wiring chart 257
- trunk data settings 334
- trunks 71
 - incoming calls, DISA 78
 - trunks, outgoing calls 78
- EAIC (equal access identifier code) 422
- electrical
 - outlet, power bar, extension cord 184
 - specifications 590
 - third-wire ground 184
- electrical connection 180
- electrical requirements 184
- emergency
 - numbers 28
 - transfer, DID trunk cartridge 261
- emergency telephone
 - BRI restrictions 248
 - installation 265
 - restrictions 265
 - troubleshooting 552
 - trunk module 222
 - with E&M/DISA trunk cartridge 258
- Enabling 492, 497
- enabling
 - a device 493
 - module or its cartridges 498
- enbloc dialing
 - description 412
 - dialing plan 412
- enhanced answer key 408
- entering numbers 288
- entering software keys 454
- environmental specifications 590
- equal access identifier code (EAIC) 422
- equipment
 - certification 29
 - installation checklist 179
 - installing optional equipment 271
 - optional auxiliary ringer installation 271
 - optional external paging 273
 - optional, external music source 272
- error message, description 241
- ETSI
 - MCID 170, 445
 - network call diversion 166
- evening schedule 356
- event messages
 - maintenance 514
 - significant 515
 - system restarts 519
- Evt 210-YYYZ 515
- Evt 211-YYYZ 515
- Evt 220-3546 515
- Evt 221-3546 515
- Evt 222-3546 515
- Evt 255 515
- Evt 260-0302 515
- Evt 261-0302 515
- Evt 263-302 515
- Evt 264-302 515
- Evt 265-302 515
- Evt 267 515
- Evt 268-07 515
- Evt 269-3546 516
- Evt 299 516
- Evt 327 516
- Evt 328 516
- Evt 329 516
- Evt 330 516
- Evt 336 516
- Evt 373 516
- Evt 400 516
- Evt 407 516
- Evt 408 516
- Evt 412-3546 516
- Evt 413-3546 516
- Evt 414-3546 516
- Evt 415-3546 516
- Evt 416-3546 516
- Evt 417-3546 516
- Evt 418 516
- Evt 419 516
- Evt 421 516
- Evt 422-3546 517

- Evt 423-3546 517
- Evt 441 517
- Evt 442 517
- Evt 453 517
- Evt 454 517
- Evt 458 517
- Evt 459 517
- Evt 680 517
- Evt 681 517
- Evt 683 517
- Evt 687 517
- Evt 688 517
- Evt 689 517
- Evt 690 517
- Evt 691 517
- Evt 692 517
- Evt 693 517
- Evt 694 517
- Evt 695 517
- Evt 696 517
- Evt 697 517
- Evt 698 518
- Evt 822 518
- Evt 882 518
- Evt 883 518
- Evt 992 518
- EVT799-XXXX YY 518
- exception (see dialing restriction)
- exiting the program 287
- expanded system 227
- expansion cabinet
 - clip ferrite bead 202
- expansion cartridge
 - installation error 218
 - installation planning 180
 - not supported 186
 - numbering 242
 - six-port 228
 - system initialization 275
 - twelve-port 229
 - two-port 227
- expansion equipment
 - installation checklist 180
 - not supported 186
- expansion module
 - 12-port cartridge 229
 - 6-port cartridge 228
 - connecting 235, 236
 - routing fibers 236
- expansion modules
 - connecting 224, 235, 239
 - fiber cable guide 232
 - fiber comb 232
 - fiber spool holder 233
 - ICS door label 233
 - spacer 233
 - spacing 232
 - wiring 237
- expired alarms, hospitality 441
- extended
 - answer key 408
 - superframe (IESF) 462
- extension
 - Direct dial 409
- extension cord 184
- extension wiring, S or T 268
- external
 - CSU, connecting the DTI 254
 - music source, impedance 271
 - paging, troubleshooting 564
 - voice message telephone number 447
- external access code
 - conflicts 367
- external call
 - CAP features 411
 - DNIS number
 - host delay 406
 - hunt group cadencing, fixed, hunt groups 391
- external code, access codes 419
- external equipment
 - music source 272
 - paging 273
- external line
 - access code conflicts 418, 419, 427
- external lines
 - auxiliary ringer 343
 - line/set restrictions 86
- external music source
 - input levels and impedance 272
 - optional equipment list 181
 - programming 272
- external paging
 - contacts diagram 273
 - external line port for talkback 273
 - output and input impedance 273

programming 273
 external terminal, tandem network 119
 external voice mail access, sets 331
 extra-dial telephone
 direct dial set 420
 programming 359

F

FCC, radio/TV interference 23
 featr settings 280
 feature
 codes, troubleshooting 584
 hospitality services 207
 hunt groups 206
 line redirection 163
 settings programming 397
 settings, see also featr settings
 using remotely 81
 feature button 282
 feature button, T7316 icon 293
 feature cartridge slot 216
 feature cartridge slots 199
 feature codes 427
 Features (Restrictions)
 Link (71) 364
 Pause (78) 364
 Programmed Release (*89)
 364
 Run/Stop (*9) 364
 Wait for Dial Tone (804) 364
 Federal Communication Commission
 (FCC) see FCC
 ferrite bead 202
 fiber cable management system
 fiber cable guide 232
 fiber comb 232
 fiber spool holder 233
 ICS door label 233
 spacer 233
 fiber cables
 connecting 235
 fiber comb 235
 fiber spool holder 235
 guide 232
 installation 230—236
 making connections 235
 routing 236
 fiber comb, description 232

fiber expansion cartridge, installation tips
 217
 fiber port allocation, ICS door label 233
 fiber spool holder, description 233
 fiber spool, using 234
 fibre cable 225
 file transfer 174
 filter 00 324
 filter 01 324
 filters
 default line restrictions 350
 default remote restrictions 351
 defaults 324
 dialing sequences 322
 hospitality room settings 440
 line restrictions 350
 maximum length 325
 overrides 350
 overriding 88
 programming 322
 remote restrictions 351
 removing 325
 removing restrictions 326
 restriction 350
 schedules 327
 see also restriction service 322—
 327
 wild card 325
 filters, see also restriction service
 fixed charge dialing, see 900
 fixed trunk, data settings 334
 fixed, BRI sampling 475
 foreign exchange (FX), CbC service 433
 framing
 disable trunk cartridge 462
 extended superframe 462
 format for T1 and PRI 462
 module status, disable trunk 462
 superframe 462
 T1 and PRI 462
 full
 autohold programming 344
 autohold, trunk/line data 334
 hospitality 440
 fwd no answer 317
 fwd on busy 317
 FX 362
 routing table 365

FX, INWATS, 900, nine hundred, see
900

G

gain

- high 347
- normal level 347
- programming 347
- trunk/line data settings 334

gain level

- CSU line bld 463

ground start trunk 72

grounded outlet 180

groundstart

- answer mode 341
- line setting 337
- trunk data settings 334

Group 4 fax using ISDN applications 174

group function, naming hunt groups 396

H

handsfree

- programming 317

handsfree button 282

handsfree/mute, assigned 314

hardware

- clock source 476
- D-channel 69
- disconnect timer, cards 460
- installation checklist 178
- interface list 280
- modules 465
- power software first 189
- programming 455
- programming CbC services 435
- setting clock source 481
- software install first 189
- system initialization 275
- top level 305
- trunk cartridges in ICS 455

heading 285

headset 181

hearing aids 28

held line reminder

- delay, programming 401
- programming 400

HF answerback 317

Hold

button 282

setting SWCA controls 403

hold

- full autohold, programming 344
- tones, music, or silence 398

hospitality

- administrative set features 207
- call restrictions 440
- features 207
- password 387
- password listing 280
- room set features 207
- room/desk information 439
- service times 440
- services programming 439
- setting alarms 441
- user interface 280

host delay 406

hotline 318

humidity, ICS 182

hung lines 555

hunt delay 394

hunt group

- page zone 390

Hunt groups

- member order 391
- usage metrics 541

hunt groups

- adding and removing members 390
- appearances 390
- broadcast 393
- busy tone 395
- call forward override 390
- delayed ring transfer 392
- description of use 389
- distributing hunt group calls 393
- external cadencing 391
- features 206, 390
- hunt delay 394
- hunt group DN 391
- listing 280
- member order 391
- moving members 391
- name display 430
- naming the group 396
- no answer 394
- overflow 395
- overflow set 396
- priority calls 390

- programming 391
- programming options 389
- queue timeout 394
- queue timeout 395
- queue, on busy 395
- ringing group 390
- rotary 394
- routing for busy lines 395
- sequential 393
- set number range 391
- temporarily leaving group 390
- unassigning lines 392
- upgrading from ILG 206
- videophones 390

I

I/F levels 461

icons on programming telephones 282

ICS

- background music 397
- BRI-U wiring 250
- cable connections 238
- cable trough 274
- cards 455
- door label, description 233
- emergency telephone installation 265
- expansion cartridge numbering 242
- expansion module spacing 232
- external loop start lines wiring chart 247
- feature cartridge slots 199
- humidity 182
- installation checklist 182
- internal modules 241
- minimum clearance 182
- minimum distance 182
- non-expanded numbering 242
- primary reference 477
- required equipment 179
- slot, installation alarm 218
- slots, diagram 216
- spacing requirements for MICS-XC 183
- ST interface card wiring 249
- system coordinator passwords, using 277

- telephone and auxiliary equipment wiring chart 245
- telephone wiring chart 244
- temperature 182
- troubleshooting 570
- trunk cartridge slots 455
- trunk module location 467
- ventilation gap 182
- wiring 241

identify device connected to the system 489

identifying the system 293

Idle 492

idle line

- full autohold 344

- search for 337

if busy 334, 339

ILG, upgrading to Hunt Groups 206

immediate signal type 345

impedance

- external pacing equipment 273

- loss package settings 344

incoming

- call routing, call-by-call 458

- calls, loop start trunks 75

- changing the COS password 85

- E&M trunk, no DISA 78

- target lines 80

- using DID trunks 76

incoming external lines, restricting 88

indicators

- power 276

- telephone buttons 284

initial configuration checklist 178

initializing the system, startup

- programming 301

inserting trunk and service cartridges

- 221

installation

- cartridges 213

- checklist 210

- clock source loops 478

- electrical requirements 184

- emergency telephone 265

- equipment and supplies checklist

- 179

- expansion equipment checklist 180

- expansion module spacing 232

- external paging system 273

- feature cartridge 219
- fiber cables 230, 232
- ICS and expansion modules
 - checklist 182
- ISDN terminal equipment 268—270
- location requirements 182
- module spacer 233
- music 271
- Norstar telephone 265
- optional equipment checklist 181
- planning checklist 178
- safety precautions 21—23
- Installer
 - interface list 280
 - password 278, 280, 301, 385
 - programming 305
- installing
 - auxiliary ringer 271
 - modules 215
 - optional equipment 271
- Integrated Communication System, see ICS
- Integrated Voice Response Center 452
- intercom
 - assigning buttons 314
 - button programming 311
 - prime line 313
- intercom DNs, conflicts 367
- intercom key
 - target lines 71, 79
- interdigit timeout, dialing rules 416
- interface levels 461
- interference, minimum distance 182
- internal CSU
- internal numbers
 - changing 397
 - length 427
- internal terminal, tandem network 120
- internal user access features 92
- internal wiring requirements 186
- internal/external number, direct dial 410
- international Inwats, CbC service 433
- Internet access 175
- internet access
 - ISDN router 67
- Internet service provider (ISP) 67
- invalid configurations, trunks 483
- Invoke by hold, SWCA 403
- Inwats, CbC service 433
- ISD/TT, I/F levels 461
- ISDN
 - applications 173—175
 - bearer capability 40
 - BRI card 48—53, 471
 - BRI card B-channels 472
 - BRI card call type 473
 - BRI card D-packet service 474
 - BRI card loop lines 471
 - BRI card loop types 471
 - BRI card loops 471
 - BRI card terminal equipment 65
 - BRI card, assign DNs 476
 - BRI card, DNs on loop 475
 - BRI card, loop DN 476
 - BRI card, LT loop 474
 - BRI card, network DNs 473
 - BRI card, sampling 475
 - BRI card, TEIs 474
 - BRI ICS wiring charts 248—251
 - BRI line, loopback test 532
 - BRI network interface wiring 252
 - BRI trunk 79
 - BRI trunk module wiring charts 262—264
 - BRI trunks
 - BRI, ST trunk modules 218
 - BRI, U2 trunk modules 218
 - BRI, U4 trunk modules 218
 - BRI-ST card 214
 - BRI-ST trunk modules 243
 - BRI-U2 card 214
 - BRI-U2 trunk modules 243
 - BRI-U4 card 214
 - BRI-U4 trunk modules 243
- capabilities 37
- clock source 476
- clocking 52—53
- data transmission speed 42
- D-channel packet service 69, 474
- default DNs 65
- desktop conferencing using 173
- devices 179
- digital access lines (DAL) 461
- DN 476
- DN default range 425
- DN range 61
- DN range, default 476
- equipment 173—175

- file transfer using 174
- framing format for T1 and PRI 462
- Group 4 fax using 174
- hardware configuration 48–52
- I/F levels 461
- installation programming 58
- integrated X.25 PAD 68
- Internet access using 175
- jack and plug pin numbering 253
- LAN access using 174
- LAN to LAN bridging using 175
- layers 39
- leased line backup using 174
- Loop DN, see also ISDN DN 65
- loop termination 222
- module port numbering 241
- network DNs 473
- network loop programming 69
- network synchronization 52–53
- OLI #, programming 315
- ordering 55
- planning service order 39
- PRI configurations 482
- PRI line setting 337
- PRI trunks 71, 79
- primary reference, clock source 477
- profile 297, 298
- profile support 297
- programing PRI lines 62
- programming BRI lines 63
- programming BRI resources 60
- programming clock source for DTI and PRI 481
- programming sequence 58
- router 67
- S interface 51
- S loop programming 65
- S loop, wiring requirements 187
- S or T loop, additional power 269
- S or T loop, wiring 268
- S reference point 51
- secondary reference, clock source 477
- see also Integrated Services Digital Network
- service provider protocol 58
- services and features 42
- set DNs 62

- software key 452
- SPID 66
- SPID, assigning to T and NT loops 472
- standards 54
- T network wiring 252
- T reference point 51
- telecommuting using 174
- terminal equipment configuration 49–51
- testing network connection 211
- timing master 477
- total DNs per system 65
- U interface 49
- U-LT loop programming 65
- U-LT reference point 49
- U-NT network wiring 252
- U-NT reference point 50
- videoconferencing and video telephony using 173
- wiring charts 248–253
- wiring requirements 186
- ISDN call connection limitation (ICCL), MCDN 45, 111, 136, 602
- ISDN loss plan 461
- ISDN, NIUF, see Bellcore/National ISDN Users Forum 57

J

- jack
 - pin numbering 253
 - U-LT pin-out 270
 - wiring for terminal 268

K

- key service unit (KSU), see ICS (Integrated Communication System)
- KSU cards, Hardware setting 455

L

- LAN
 - access using ISDN applications 174
 - router 175
 - to LAN bridging ISDN applications 175
- languages

- display 321
- profile 1 297
- profile 2 297
- profile 3 298
- profile 4 298
- User Preferences 289
- last dialed digits 82
- leased line backup using ISDN
 - applications 174
- least-cost routing
 - creating routing over private network 377
- leaving the program 287
- LEDs
 - DTI 567
 - power indicators 276
- lightning protectors 187
- line
 - assign prime set 340
 - assignment 309
 - BRI, about 79
 - capacity of trunk cartridges 185
 - default line restrictions 350
 - deprovisioning 524
 - filters 86
 - held reminder programming 400
 - line pool types 336
 - loopback test 526
 - number range 468
 - pool
 - in a dialing plan 94
 - troubleshooting 585
 - profile, reviewing programming 293
 - programming alarmsset 406
 - programming ANI number
 - programming answer keys 408
 - programming answer mode 341
 - programming answer with DISA 342
 - programming auto privacy 340
 - programming auxiliary ringer 343
 - programming CAP assignment 411
 - programming dial mode 338
 - programming dialing plan 412
 - programming direct dial 410
 - programming DNIS number
 - programming DTI 337
 - programming full autohold 344
 - programming gain 347
 - programming host delay 406
 - programming if busy 339
 - programming line restrns 350
 - programming link signal (link at CO) 343
 - programming link time 406
 - programming loss package 344
 - programming message reply enh 407
 - programming name 349
 - programming received number 339
 - programming remote restrns 351
 - programming restrictions 349
 - programming restrn filters 350
 - programming set relocation 407
 - programming signal type 345
 - programming system telco features 352
 - programming trunk mode 341
 - programming trunk type 335
 - programming voice msg center 352
 - programming, viewing the settings 294
 - provisioning 524
 - public, private to, pool 336
 - redirection feature 163
 - restriction 86
 - ringing service, auxiliary ringer 344
 - search for idle 338
 - selecting first line 313
 - target line ring 339
 - troubleshooting 553–561
 - trunk/line data, copying 335
 - type 336
 - viewing assigned lines 311
 - voice message routing 447
- line access
 - listing 280
 - programming CbC services 435
 - programming for sets 308
- line build, CSU 463
- line buttons
 - loop start 76
 - maximum 311
 - no buttons 311
- line coding 464
- line feature, auto privacy 340
- line filter 383
- line keys, limits 310

- line numbers 288, 468
- line pool
 - access code 417, 424
 - access code coordination 102
 - access codes 337
 - assign 336
 - E&M trunk for ring again 338
 - limit to outgoing 336
 - loop start 76
 - PRI trunks 71, 79
 - prime line 313
 - programming line access 337
 - target lines 338
 - types 336
- line pool access code 74
 - auto DN 74
 - conflicts 339, 418, 419, 420, 421, 427
 - programming 312
 - with DISA 74
- line pool codes
 - conflicts 303, 367
- line pools
 - dialing plan for shared pools 102
 - PRI 312
 - programming 436
 - programming tip 316
- line redirection, calling name information 430
- line restrictions
 - defaults 350
 - programming 350
 - remote access 74
- line selection, for a direct-dial telephone 410
- line settings, ringing 359
- line supervision, disconnect timer, on card 460
- line type
 - programming pool for prime line 313
 - trunk/line data settings 334
- line/set
 - filters 86
- line/set restriction
 - filters 86
 - maximum 329
 - user filter 383
- lines
 - assigning, hunt groups 392
 - BRI card 471
 - dialing filters 87
 - external codes 419
 - line button 63
 - listing 280
 - remote access package 423
 - setting auxiliary ring 271
 - single SPID 63
 - SWCA keys 403
 - top-level 304
 - trunk type data settings 334
 - trunk/line data programming 333
- link
 - blocking use of 328
 - F71 343
 - outgoing restrictions 343
 - programming link at CO 343
- link at CO 334
- link signal, dialout 364
- Link status 485
- link status, user interface 280
- link time 406
- list button 286
- local calling, setting up route 371
- location
 - private access codes 95
 - UDP code 414
 - UDP private DN length 95
- location requirements
 - installation planning 182
- log
 - network evt 504
 - system administration 502
 - system test 499
- log space
 - number of spaces 332
 - programming 332
- logging calls
 - MCID 170, 445
- long distance
 - adding an access code 375
 - carrier code 125
 - setting up route 373
- long telephone numbers 288
- longCO 345
- longPBX 345
- loop
 - BRI card 471

- BRI card, DN on loop 475
- line numbers 468
- network programming 69
- view card 456
- loop DN
 - BRI card 65, 476
- loop performance 269
- loop start
 - answer mode 341
 - answer with DISA 342
 - as prime line 76
 - configuring 185
 - data settings 334
 - disconnect supervision 82, 341
 - E&M requirements 76
 - emergency telephone 265
 - for target lines 80
 - full autohold 344
 - line pools 336
 - line setting 337
 - loop start signalling 76
 - loss package settings 345
 - MICS-XC compatibility 77
 - no set lines 309
 - ONN blocking 451
 - outgoing 76
 - providing direct dialing capability 76
 - remote access 81
 - remote access, public network 82
 - trunk 75, 214
 - trunk cartridge wiring chart 256
 - trunks 71
 - wiring 186
 - wiring chart 247
- loop start signalling, supporting trunk
 - cartridges 76
- loop start trunk
 - auto-answer 75
 - incoming calls 75
- loop supervision, see disconnect
 - supervision
- loop termination
 - ISDN terminal 222
 - shorting straps 223
- loop type, BRI card 471
- loopback test
 - BRI lines 532
 - initiated by the central office 529
 - initiated from Norstar 529

- starting 530
- loops
 - no bridge taps 187
 - profile support 297
 - S or T extension wiring 268
- loss level 461
- loss package
 - descriptions 345
 - programming 344
 - trunk/line setting 334
- loss/gain settings 344
- lowest, park mode 399
- Lp, BRI LT loop 474
- LT loop
 - BRI card 474
 - D-packet service 474
- lunch schedule 356

M

- M1, see Meridian
- M7100 telephone, accessing external
 - lines 419
- M7310, programming telephone 282
- M7324
 - CAP assignments 411
 - programming telephone 282
- maintenance 280
 - alarm codes 506
 - beginning a session 486
 - bipolar violations 537
 - carrier failure alarms 536
 - CSU stats 533
 - current alarm 500
 - device version number 491
 - disabling module/cartridges 498
 - enabling the module/cartridges 498
 - event messages 514
 - identify device connected to system
 - 489
 - module 495
 - network event log 504
 - port/DN status 488
 - provisioning 522
 - short term alarms 537
 - state
 - of a cartridge 497
 - of a module 496
 - of device 491

- system
 - administration log 502
 - test log 499
- system administration log 502
- system version 487
- top level 305
- making a call using destination codes 376
- Malicious call identification (MCID)
 - programming 170, 445
- manual answer
 - E&M trunks 77
 - line appearances 78
 - loop start trunk 75
- map table, call by call routing 459
- maxi system
 - module ports 227
 - trunk module location 467
- maximum incoming calls, CbC limits 437
- maximum line buttons 311
- maximum outgoing calls, CbC
 - programming 437
- MCDN
 - APN network features 111
 - break-in 143
 - camp-on feature 142
 - ISDN call connection limitation (ICCL) 45, 111, 136, 602
 - Meridian configurations 125
 - network call redirection information (NCRI) 134
 - network features 141
 - see also PRI and APN
 - software code 110
 - software key 452
 - trunk anti-tromboning (TAT) 45, 111, 140
 - trunk route optimization (TRO) 138
- medium, hospitality 440
- mediumCO 345
- mega system 227
- member DNs 391
- member order, hunt groups 391
- memory button
 - CAP 411
 - loop start 76
- Meridian
 - advanced private networking 121, 126
 - MCDN 125
 - networking 89
 - networking with SL-1
 - SL-1 network 125
- message
 - reply enh programming 407
 - waiting indicator, see also MWI 331
- messages
 - CAP 411
 - network features 141
- MICS
 - basic password 281
 - behind a PBX 93
 - default destination codes 368
 - default DID line numbering 310
 - electrical
 - connection 180
 - ISDN DNs 65
 - maximum 8 modules 455
 - mounting the modules 215
 - NVRAM cartridge 192
 - planning checklist 178
 - power the system 274
 - power, PS1, PS2, PS3 269
 - private network caller features 93
 - private network tandem calling (PNTC) 112
 - remote access caller features 92
 - software keys 452
 - software upgrade tool 193
 - station module 466
 - system coordinator password 281
 - system functionality 31
 - system internal caller features 92
 - system overview 188
 - trunk modules 467
 - upgrading to MICS-XC 196
- MICS-XC
 - basic password 281
 - Companion software key 452
 - connecting expansion modules 239
 - default DID line numbering 310
 - fiber connections 235
 - interface headings 280
 - loop start trunk compatibility 77
 - maximum 14 modules 455
 - mounting the modules 215
 - powering the system 274
 - software keys 452

- software upgrade tool 193
 - station module 466
 - system coordinator password 281
 - system functionality 31
 - system overview 188
 - trunk modules 467
 - upgrading from MICS 196
 - US systems, upgrading, UTAM 196
 - MICS-XC, see also ICS
 - midi system
 - module ports 227
 - trunk module location 467
 - minimum clearance 182
 - minimum incoming calls, CbC limits 437
 - minimum outgoing calls, CbC
 - programming 437
 - model 289, 321
 - modify, NRU 363
 - Modular 8X24 KSU, replace with 0X32 ICS 195
 - Module status 485
 - module status
 - enabling/disabling cartridges 467
 - listing 280
 - modules
 - ASM features 466
 - brackets 215
 - BRI B-channels 472
 - BRI call type 473
 - BRI card, assign DNs 476
 - BRI card, DNs on loop 475
 - BRI card, D-packet service 474
 - BRI card, loop DN 476
 - BRI card, sampling 475
 - BRI loop lines 471
 - BRI loop types 471
 - BRI loops 471
 - BRI LT loop 474
 - BRI network DNs 473
 - BRI TEIs 474
 - check number of trunk cartridges 496
 - checking the state 496
 - connecting 240
 - connecting multiple modules 226
 - Data Module 483
 - enabling 498
 - fiber cable guide 232
 - fiber spool holder 233
 - hardware 465
 - ICS and feature cartridge slots 216
 - ICS door label 233
 - mounting 215
 - non-expanded numbering 242
 - numbering 242–243
 - port DNs 241
 - port numbers 241
 - power LEDs 276
 - show system modules 455
 - showing inventory 495
 - spacer 233
 - Station Module 466
 - troubleshooting 570–588
 - Trunk Module 467
 - verifying ports 467
 - verifying status of analog module 466
 - wiring 237
 - wiring charts 241
 - monitoring
 - call usage set 72
 - incoming call usage 309
 - mounting bracket 216
 - moving telephones 267
 - moving telephones, also see set relocation
 - msgIndicate 320
 - multi-line
 - hunt 42
 - hunt groups
 - ordering 57
 - multiple modules 226
 - multiple target lines, broadcast ring 309
 - music
 - adjust volume of external source 272
 - background music 397
 - installation 271
 - license 28
 - on hold 398
 - source 25, 272
 - MWI, assigning to a line 331
- N**
-
- name
 - programming for lines 349
 - terminals&sets 280, 320

- trunk/line data 280
- name display, ANI number 346
- National ISDN standards 54
- national length, profile 2 428
- network
 - access, CbC services 433
 - APN features 111
 - APN, see also MCDN 121, 126
 - behind PBX 93
 - caller information on SL-1 111
 - calls within network 160
 - CDP call routing 131
 - clock source settings 478
 - configuration samples ??—109, 155—171
 - configurations 91—??
 - controlling access 85
 - COS 85
 - destination code number 96
 - E&M dialing plan 97
 - event log 504
 - external termination, tandem network 119
 - internal termination, tandem network 120
 - line pool access codes 102
 - line pool access, set 104
 - log, check items 505
 - node 82
 - options 92
 - private access codes 95
 - private DN length 95
 - private systems to Norstar system 93
 - private, call scenarios 159
 - public network to Norstar system 92
 - restriction filter 86
 - SL-1 features 110
 - tandem 102
 - tandem network 112
 - target line 82
 - test BRI network connection 211
 - transparent dialing plan 94
 - troubleshooting 576—588
 - user problems 576
 - using destination codes 96
 - using E&M trunks 162
 - using SL-1 110
- Network Call Diversion 47, 165, 443, 604
- Network call diversion (NCD) programming 166
- network call redirection information (NCRI), MCDN 134
- network calls
 - creating autodial 104
 - external calls 104
- Network DN
 - BRI card 473
- network DN 60
 - call type 473
 - incoming calls 63
 - received number 339
 - single SPID 63
- Network evt log 485
- network evt log 280
- network loop programming 69
- network name display
 - calling party name 429
 - connected name, receiving and sending 430
 - hunt group 430
 - interactions 430
 - OLI# 430
 - other programming, OLI#, Called ID, CLID set 431
 - private/unknown names 429
 - programming 431
 - programming BusName 429
 - protocols, supported 429
- network services
 - listing 280
- network specific facilities, see NSF
- networking
 - MCDN features 141
 - MCDN, break-in 143
 - MCDN, camp-on feature 142
 - MCDN, ISDN call connection limitation (ICCL) 45, 111, 136, 602
 - MCDN, network call redirection (NCRI) 134
 - MCDN, trunk anti-tromboning (TAT) 45, 111, 140
 - MCDN, trunk route optimization (TRO) 138
- next 285

- NI-2, protocol 457
 - night ringing service schedule 358
 - night schedule 356
 - night service 357
 - nine hundred, see 900
 - NIUF, see Bellcore, National ISDN Users Forum
 - No free lines 561
 - node 82
 - Non Volatile Read-only Memory, see NVRAM
 - non-expanded system (ICS alone)
 - numbering 242
 - normal rte, destination codes 370
 - normal service
 - line restrictions 350
 - remote restrictions 351
 - Norstar
 - as off-premise extension 93
 - sets 179
 - starting the system 274
 - telephones 179
 - Norstar Remote Utilities, see NRU 363
 - Nortel Customer Response Center 452, 453
 - Not available 492, 559
 - Not in service 559
 - notify set, hospitality 441
 - NSF
 - extensions 457
 - NI-2 protocol, with CbC services 457
 - NT1 211, 252
 - stand alone connections 54
 - numbering, trunk module lines 205
 - numbers, entering 288
 - NVRAM cartridge
 - installation diagram 219
 - limitations 192
 - required equipment 179
- O**
-
- occupancy, room 440
 - OLI#
 - name display 430
 - network name display programming 431
 - PRI, call display 316
 - programming 315
 - on hold 398
 - ONN blocking 432
 - 819, ONN blocking 448
 - 819 432
 - listing 280
 - loop start on BRI card 451
 - on BRI 450
 - programming 432, 448
 - setting up modules 450
 - suppression bit 450
 - tone 432
 - VSC 449
 - open switch interval (OSI), description 341
 - disconnect timer 460
 - optional equipment
 - auxiliary ringer 271
 - auxiliary ringer, programming 343
 - external music source 272
 - external paging 273
 - installation 181
 - installation checklist 186
 - installing 271
 - troubleshooting 562—564
 - optional features
 - programming alarm set 406
 - programming answer keys 408
 - programming AutoTime&Date 402
 - programming background music 397
 - programming call log space 405
 - programming camp timeout 398
 - programming CAP assignments 411
 - programming daylight time 402
 - programming dialing plan 412
 - programming direct dial 410
 - programming directed pickup 401
 - programming DRT 400
 - programming DRT delay 400
 - programming held line remind delay 401
 - programming held reminder 400
 - programming host delay 406
 - programming link time 406
 - programming message reply enh 407

- programming on hold 398
- programming page timeout 402
- programming page tone 401
- programming park mode 399
- programming park timeout 399
- programming receiver volume 398
- programming set relocation 407
- programming transfer callback 399

OPX 266

OSI (open switch interval) 341

outgoing

- calls, routing table 365
- E&M trunks 78
- external routing codes 106
- host delay 406
- PRI lines 105
- restriction filters 86
- using loop start 76

outgoing name and number block, see

ONN blocking

Outwats

- carrier access codes 365
- CbC service 433
- routing 362
- routing table 365

overflow

- Hunt group 206
- in queue 395
- routing, schedules 379

overflow set, hunt groups 396

overlay

- button definitions 285
- positioning on the set 283

overrides

- maximum
- restriction filters 86, 350

P

packet service 69

page timeout 402

page tone 401

page zone

- Capabilities 317
- hunt group 390

paging

- Capabilities 317
- equipment connections 273

external output and input

impedance 273

park mode 399

park prefix

- access codes 418
- conflicts 303, 418, 419, 427

park timeout 399

pass codes, see software keys

passive bus 269

password

- admin 281
- basic 278, 281, 386
- call log programming 384
- calls answered with DISA 421
- cond pswd 387
- COS 74
- COS user filter 383
- desk pswd 387
- dialpad 278
- Hospitality password 387
- Installer 278, 280, 301, 385
- profile 278
- registration 386
- registration password 386
- System Coordinator 278, 281, 386
- System Coordinator Plus 280, 386
- System Coordinator plus 306
- system coordinator Plus 278
- user 281

password keys, see software keys

passwords

- COS, using DISA 89
- interface list 280
- programming 277, 278, 382
- programming passwords 385
- top level 304

Pause (F78) 364

payload loopback test 526

PBX, using Norstar 93

phantom circuits 269

phantom DN 409

physical trunks 309

pickup grp 317

pin number, ISDN jack 253

planning checklist, installation 178

plug pin numbering 253

PNTC

- external termination 119

- internal termination 120

- networking features 110
 - using SL-1
- point-of-sale terminal adapter, see POSTA
- point-of-sale terminals 68
- port numbering 241
- port numbers 241
- port, verifying module ports 467
- Port/DN status 485
- port/DN status 280, 488
- positioning the overlays 283
- POSTA
 - BRI 69
 - Bri cards, D-packet service 68
- power
 - LEDs 275
 - losing call log information 276
 - S or T loops 269
 - specifications 589
 - system indicators 276
 - warm start 275
- power bar 184, 274
- power cords 184
- powering the system
 - process 274
 - service cable connections 274
- prefix
 - conflicts 427
 - public network, dialing plan 415
- PRI
 - B channel sequence 458
 - BusName, network name display 429
 - Call-by-call services over network 104
 - card download 59
 - carrier failure, standard 460
 - CbC destination codes 362
 - CbC limits 437
 - CbC service selection 433
 - CbC trunk allocation 105
 - choosing lines for call 310
 - CO fail 460
 - configurations 482
 - configuring CbC 105
 - connecting to service provider 254
 - connecting wiring 239
 - dialing plan, 2-way DID 108
 - dialing with intercom 310
 - DTI 179
 - framing 462
 - invalid digital trunk configurations 482
 - invalid mixed trunk configurations 483
 - ISD/TT 461
 - line appearances 310
 - line numbers 468
 - line pools 312
 - line restriction rules 322
 - line setting 337
 - Meridian 1 networking (MCDN) 121, 126
 - Meridian M1 network configuration 125
 - network name display 429
 - networking 124
 - networking using SL-1 110
 - no DISA on trunk 83
 - no prime line 313
 - OLI # 316
 - profile support 297, 298
 - programming call limits 437
 - programming CbC services 435
 - programming clock source 481
 - programming DISA 64
 - programming line pools 436
 - programming lines 62, 308
 - programming routing table 366
 - remote access trunk 83
 - remote access, DISA 81
 - selecting a protocol 456
 - service types routing table 365
 - SL-1 networking features 110
 - SL-1 tandem network 112
 - software code 110
 - software key 452
 - suppression bit 450
 - target line, if busy 339
 - through-fed repeaters 237
 - trunk 71, 79
 - trunk data settings 334
 - valid digital trunk configurations 482
 - valid mixed trunk configurations 483
 - view card 456
- PRI channel

- disabling 524
- PRI channel, disabling 524
- PRI line
 - provisioning 523
- PRI line, provisioning 523
- PRI-A 312
- PRI-B 312
- Primary Rate Interface trunk, see PRI
- primary reference, clock source 477
- prime line
 - assign line pool 337
 - describing 313
 - DID 313
 - exception 74
 - external line assignment 313
 - intercom 313
 - line pool 313
 - no PRI 313
 - prime telephone 313
 - programming as intercom 338
 - programming line type pool 313
 - target line 313
- prime set
 - assign DN 340
 - auto-answer calls 340
 - DRT 400
 - prime line 313
 - received number 339
 - trunk type data 334
- priority call 317
- priority, hunt group 390
- PrivAccCode 421
- privacy, programming auto privacy 340
- private
 - CbC service 434
 - PRI protocol 456
 - routing table 365
- private access codes
 - conflicts 421
 - network 421
 - UDP 95
- private DN length
 - dialing rules 415
 - networking 95
- Private DN, CbC over Tie 106
- private line 336
- private name 429
- private network
 - additional configuration 124
 - auto-answer, DISA DN, Auto DN 83
 - call routing codes 121
 - CDP call routing 131
 - dialing plan 413
 - DID trunks 83
 - DISA 89
 - E&M no DISA 82
 - E&M trunk answer mode 342
 - E&M trunks 71
 - MCDN break-in 143
 - MCDN camp-on feature 142
 - MCDN ISDN call connection
 - limitation (ICCL) 45, 111, 136, 602
 - MCDN network call redirection
 - information (NCRI) 134
 - MCDN software key 452
 - MCDN trunk anti-tromboning (TAT) 45, 111, 140
 - MCDN trunk route optimization (TRO) 138
 - PNTC call routing 116
 - private access code 421
 - private access codes 95
 - private network ID 414
 - PSTN calls 124
 - Public DN, CDP 94
 - public DNs 124
 - remote access 82
 - sample configurations 159–162
 - SL-1, private network tandem
 - calling (PNTC) 112
 - tie lines 156
 - UDP 414
 - using E&M trunks 162
- private network tandem calling, see PNTC
- private networking (APN), see also MCDN 121, 126
- private number 332
- private numbering plan, CbC dialing 106
- profile
 - changing 299
 - installation checklist 178
 - password description 278
 - profile 1, North America 297
 - profile 2 297
 - profile 3 298
 - profile 4 298

- programming 296
- programming headings 279
- trunk cards, profile 1 297
- trunk cards, profile 2 297
- trunk cards, profile 3 298
- trunk cards, profile 4 298
- profile 1, languages 297
- profile 2, languages 297
- profile 3, languages 298
- profile 4, languages 298
- programmed release, dialout 364
- programming
 - 1st display 331
 - access 278
 - access codes 416
 - allow last number redial 328
 - allow link 328
 - allow saved number redial 328
 - analog and BRI ONN 432
 - analog VSC 449
 - ANI number
 - answer mode 341
 - answer with DISA 342
 - ATA ans timer 319
 - auto DN 420
 - auto privacy 340
 - auxiliary ringer 271, 343, 360
 - basic admin password 281
 - basic password 278, 386
 - BRI card 471–476
 - BRI lines 63
 - BRI resources 60
 - business name 431
 - BusName 429
 - busy lines, hunt groups 395
 - button definitions 285
 - call log password 384
 - call restrictions, hospitality 440
 - called ID 332
 - CAP assignment 411
 - capabilities 317
 - clock source for DTI and PRI 481
 - control telephone 354
 - copy trunk/line data 335
 - copying telephone programming 290
 - COS line filter 383
 - COS password 382
 - day-to-day changes 307
 - dial mode 338
 - dialpad 278
 - dialpad headings 279
 - dialpad, CCITT 300
 - display buttons 285
 - DN length 427
 - DNIS number
 - enable/disable trunk cartridge 464
 - entering 306
 - exiting 287
 - external code 419
 - external music source 272
 - extra-dial telephone 359
 - feature settings 397
 - full autohold 344
 - gain for E&M line 347
 - handsfree/mute 314
 - hardware 455–483
 - hospitality cond password 387
 - hospitality desk password 387
 - hospitality password 387
 - hospitality services 439
 - hunt delay 394
 - hunt group function name 396
 - hunt groups 391
 - if busy 339
 - indicators, telephone programming
 - buttons 284
 - insaller 305
 - installer password 278, 385
 - ISDN 58
 - ISDN PRI lines 62
 - least cost routing 377
 - line access 308
 - line keys, limits 310
 - line name 349
 - line pools 336
 - line pools for CbC 436
 - line restrictions 350
 - line type 336
 - lines 333–352
 - lines to DTI 337
 - link at CO 343
 - log space 332
 - loss package 344
 - maintenance 485–538
 - ONN 432
 - overflow
 - defining set, hunt groups 396

- overlay 283
- passwords 277, 278, 382—386
- PRI routing table 366
- prime set 340
- profile headings 279
- programming overview 278
- programming telephones 282
- received number 339
- registration password, Companion 386
- release reasons 438
- remote access 423
- remote restrictions 351
- restriction service 360
- restrictions 349
- reviewing lines 293
- reviewing sets 293
- ring delays 291
- ringing groups 359
- ringing service 357
- routing 95
- routing requirements 363
- routing service 361
- schedule names 355
- schedule times 355
- services 353—357
- set lock 328
- set name 431
- signal type 345
- software keys 452
- special characters 285
- startup 301—303
- startup headings 279
- system 277—293, 389—427
- system coordinator 306
- system coordinator password 278, 281, 386
- system coordinator plus password 278, 386
- system features 352
 - remote restrictions 351
 - restriction service 322—329
- system speed dial 381
- telco features 330, 352, 447
- telco features (system-wide) 352
- Terminals&Sets 308—332
- Time&Date 388
- timing for startup 301
- tools 282
- top-level 304
- trunk answer 357, 358
- trunk mode 341
- trunk type 335
- trunks and lines 333
- user preferences 289
- viewing assigned lines 311
- viewing line 294
- viewing updates 287
- VMsg center, on lines 352
- VSC for BRI 449
- programming record
 - about the overlays 283
 - description 287
 - planning the routing service 361
 - routing service 365
- programming system features
 - Caller ID set 330
- progrmmg pswds 280
- protocol
 - selecting 456
 - service provider 58
 - supporting call by call services 433
- Provisioning 485
- provisioning
 - DTI card 456
 - listing 280
 - T1 lines 523
- PS1, power 269
- PS2, power 269
- PS3, power 269
- PST
 - adapter, RS-232 interface 69
 - network loop programming 69
- PSTN
 - analog access lines 461
 - external routing code 106
 - I/F levels 461
 - on a network 111
- PSU LEDS 275
- Pswd, see password
- public
 - CbC service 433
 - PRI protocol 456
 - routing table 365
- public calls, Auto DN 157
- Public DN
 - dialing plan 415
 - external routing code 106

- private network 124
- public network call scenarios 155
- public networks, CDP 94
 - using with CDP 94
- Public DN length, private networking 124
- public line 336
- public network
 - call descriptions 155—163
 - carrier codes 125
 - dialing plan 413, 415
 - DID trunk
 - DISA 89
 - loop start trunks 71
 - PNTC routing 113
 - using DID 158
- pulse signalling 338

Q

- Q, dialpad 278, 300
- queue 395
- queue timeout, hunt groups 394, 395
- queues, Hunt groups 206

R

- reallocating log space 405
- Rec'd # length 426
- Rec'd # length, listing 280
- receive objective loudness rating (ROLR) 461
- receive, setting gain 347
- received number
 - conflicts 339
 - target lines 339
 - trunk/line data 334
- received number length
 - DISA DN 421
 - programming 426
- receiver volume 398
- receiver, see also handset
- receiving
 - calling name 429
 - connected name 429
 - redirected name 429
- receiving calling name 429
- redirection
 - line redirection 163
 - ring 318
- re-entering software keys 453

- reg. pswrd 280
- region 279
- registration password 386
- regulatory information 23
- Release button
 - icons 282
- release button 287
- release reasons
 - listing 280
 - programming 438
- relocating
 - CAP module 412
 - telephones 267
- remind delay 401
- remot access packages
 - COS 423
- remote access
 - caller features 92
 - COS password 382
 - default restrictions 351
 - defaults 424
 - DID trunks 83
 - DISA 64
 - DISA DN, programming 421
 - E&M trunks 82
 - filters 87
 - line packages 423
 - line restrictions 351
 - listing 280
 - loop start trunks 75, 82
 - PRI trunk 83
 - private network 82
 - programming 423
 - public network 82
 - remote pkg 384
 - restricting 423
 - restricting outgoing calls 88
 - restrictions 76
 - setting link time 406
 - system access 81—83
 - through network 92
 - trunk types 81
 - users, troubleshooting 576—588
 - using Call by Call programming
- remote access packages
 - copy 424
- remote feature code 74
- remote feature request 82
- remote filters 74

- remote line access
 - remote packages 423
- remote line access, programming 423
- remote packages 74
 - programming 384
 - remote line access 423
- remote restrictions
 - default filters 351
 - filters 383
 - process chart 88
 - programming 351
- repair facility 28
- replacing a telephone
 - of different types 551
 - of same type 551
 - status 552
- required equipment 179
- reset logs 405
- reset memory 279, 302
- restore, NRU 363
- restricting
 - line at telephone 329, 349
 - remote access 423
 - remote callers 351
 - telephones 322, 327
- restriction
 - default 324—327
 - filters 350
 - service 322, 349—352
 - line/set 329
- restriction dialing, setting up routes 380
- restriction filters
 - assign to sets 327
 - auto-answer 82
 - call routing 103
 - COS 85
 - default line restrictions 350
 - network 86
 - overrides 86
 - remote restrictions 351
 - removing filters 326
- restriction service 349
- restrictions
 - 911 324
 - default filters 324
 - hospitality services 440
 - lines 280
 - link signal 343
 - programming 349, 360
 - programming for terminals and sets 322
 - removing filters 325
 - schedules 86
 - see also Terminals&Sets and Lines 361
 - set restrictons 327
 - terminals&sets 280
- Restrtn service, list 280
- retrieving
 - calls, park prefix 418
 - voice messages 447
- retry intrvl 441
- reusing trunk and station modules 199
- reviewing line programming 293
- reviewing set programming 293
- RIN, see ringer equivalence number
- ring again, assign E&M trunk to line pool 338
- ring delay, programming 291
- ring only 147, 152, 309, 390
- ring transfer, hunt groups 392
- ring type 289, 321
- ring/call distribution, Hunt group 206
- ringer equivalence number
 - Canada 28
 - US 27
- ringer, auxiliary ringer 343
- ringing
 - broadcast, hunt groups 393
 - hunt delay 394
 - rotary, hunt groups 394
 - sequential, hunt groups 393
 - target line 339
- ringing group
 - hunt group 390
 - programming 359
 - ringing service 357
 - schedules 360
- ringing service
 - auxiliary ringer 344
 - list 280
 - night schedule 358
 - ring group assignment 358
 - ringing groups 357
- RJ-21
 - DID wiring 259
- RJ2HX/CA2HA distribution block
 - cross connections 257

-
- ROM software cartridge 179, 219
 - room # 439
 - room condition 207
 - room occupancy 207, 440
 - room vacancy 440
 - room/desk information, hospitality 439
 - rotary 206, 394
 - route numbers 363
 - router, ISDN 67
 - routing
 - adding a long distance access code 375
 - carrier code 125
 - carrier codes 422
 - CDP 131
 - destination codes 363
 - dialing restrictions 380
 - dialout 364
 - for least cost routing 377
 - for long distance calling 373
 - hunt group 206
 - incoming DID calls 106
 - normal route 370
 - overflow 379
 - programming 95
 - programming CbC services 436
 - programming requirements 363
 - sample for local calling 371
 - sample for long distance calling 373
 - setting up leading digits 96
 - tandem networks 119
 - routing service
 - list 280
 - planning 361
 - programming 361
 - routing table
 - CbC service 365
 - checking internal dialing 361
 - PRI dialing plan 366
 - using SID 365
 - voice message routing, telco features 447
 - Run/Stop, dialout 364
- S**
-
- S interface, ISDN 51
 - S loop
 - power 269
 - sampling 475
 - S or T reference point 51
 - S reference point 51
 - safety precautions 21—23
 - sample configurations, private network 159
 - sampling
 - BRI card 475
 - S loop 475
 - SAPS
 - optional equipment list
 - wiring loops 187
 - Sched 4 356
 - Sched 5 356
 - Sched 6 356
 - schedules
 - activating services 353
 - assigning filters 327
 - control sets 355
 - controls 358
 - default line restrictions 350
 - default names 355
 - default remote restrictions 351
 - default times 356
 - night ringing service 358
 - overflow routing 379
 - remote restrictions 351
 - restriction service 86
 - ringing groups 360
 - SDS
 - secondary reference
 - clock source 477
 - security
 - COS 85
 - dialing filters 86
 - selective line redirection (SLR) 430
 - self-test, system initialization 275
 - sending calling party name 429
 - sending calling name 429
 - sending connected name 429
 - sequential 393
 - sequential mode 206
 - service
 - schedule control 358
 - service cartridge
 - installation tips 217
 - installing 221
 - service ID (SID)
 - service identifier, see SID

- service profile identifier, see ISDN and SPID
- service provider
 - connecting T1 and PRI 254
 - connecting to external CSU 254
 - ISDN protocol 58
- service time
 - hospitality 440
- service tone cadences 589
- service types 64
 - CbC limits 437
 - routing table 365
 - using SID 365
- services
 - activating from control set 353
 - assigning direct dial numbers 420
 - call ringing, dialing restrictions, call routing 353
 - cartridge, IVD services card 179
 - CbC selection for PRI 433
 - control set 354
 - control sets 354
 - evening 356
 - example of alternate call ringing 353
 - line restrictions 350
 - list 280
 - lunch 356
 - night 356
 - programming CbC services 435
 - programming common settings 381
 - programming restrn services 360
 - programming ringing groups 357
 - programming ringing sets 359
 - programming routing service 361
 - ringing service 357
 - ringing, auxiliary 344
 - Sched 4 356
 - Sched 5 356
 - Sched 6 356
 - schedule names 355
 - schedule times 355
 - start and stop times 355
 - top level 304
 - turning on separately 353
- services card, clock source 478
- set
 - feature and number restrictions 327
 - filters, description 86
 - filters, E&M trunks 88
 - profile, reviewing programming 293
 - user restrictions 86
- set interface, programming 277
- set lock 328
- set name
 - BusName 429
 - network name display 431
 - programming 431
- set relocation
 - deactivate 407
 - programming 407
 - relocation enabled 267
 - tips 267
- set restriction
 - default 327
 - filters 87
 - lines 74
 - Link 328
- sets
 - assigning target lines 309
 - basic password for programming 278
 - OLI as called # 315
 - programming, system coordinator password 278
 - setting auxiliary ring 271
 - viewing telephone programming 294
- shared line pools, dialing plan 102
- shedule names 355
- shortCO 345
- shorting straps 223
- shortPBX 345
- show 285
- show group 391
- show module 455, 456
- show set 147, 148, 151, 153, 308, 439
- SID
 - routing table 365
- side circuits 269
- signal
 - method 27
 - programming type 345
 - trunk/line data settings 334
- signal is immediate 338
- significant event messages 515
- silent, on Hold 398
- simultaneous calls 310

- single-line telephone
 - emergency phone 265
 - off-site 266
- six-port expansion cartridge 228
- SL-1
 - MCDN software key 452
 - network 121, 126
 - network caller information 111
 - networking features 110
 - private network tandem calling 112
 - private PRI protocol 456
 - software code 110
- SL-1 networking 110
- slots on ICS 199
- SLR, see selective line redirection
- softkeys, see display buttons
- software
 - DNIS for third-party 346
 - MICS and MICS-XC 31
 - NVRAM installation 219
- software key
 - Companion 452
 - ISDN 452
- software keys
 - entering 454
 - programming 452
 - re-entering 453
 - system ID 453
 - top level 304
 - user interface 280
- softwarey keys
 - MCDN 452
- space allocation, call log space 405
- spacer, description 233
- spacing requirements, ICS 183
- special characters on display 285
- specifications
 - CSU 591
 - DTI 591
 - electrical 590
 - environmental 590
 - power 589
 - service tone cadences 589
 - telephone loop 589
- SPID
 - assigning to BRI 472
 - B channels 63
 - creating terminal SPID 66
 - defining lines 309
- OLI# 316
 - programming ISDN terminals 62
 - T/NT loops, assigned 472
- SrvCode for VSC 450
- ST line numbers 468
- standard time, see daylight time
- start and stop times, services 355
- start DN
 - changing at startup 302
 - Startup 279
- starting the system 274
- startup 244
 - changing start DN 302
 - default filters 325
 - dialpad password 278
 - DN length settings 427
 - installer password 278
 - profile password 278
 - programming 301
 - programming headings 279
 - run Profile and Dialpad first 296
 - timing for startup 301
- Startup code, installation checklist 178
- startup programming 275
- state of device, check 491
- static DID 109
- station auxillary power supply, see SAPS
- Station Module 466
- station module
 - connecting 224
 - fiber comb 232
 - installation planning 186
 - port numbers 241
 - power 275
 - troubleshooting 575
 - wiring chart 255
- status, analog module 466
- super 341
- superframe (SF) 462
- supervisory signaling, DID 261
- supported upgrades 192
- suppression bit 450
 - PRI 450
 - SuprsBit, ONN blocking 450
- suttered dial tone 74
- SWCA
 - defining appearance keys 403
 - setting controls 403
- switched digital

- CbC service 434
 - routing table 365
- switches
 - matching signal types 345
- switches, NSF extensions 457
- `sys admin log` 485
- `sys admin log` 280
- `sys speed dial` 280, 304
- `sys test log` 485
- `sys test log` 280
- SysID 280
- sysID 453
- system
 - administration log 502
 - basic password 278
 - coordinator password 278
 - coordinator plus password 278
 - network configurations 91—??
 - processor software 487
 - programming, see also system prgrming 277—293
 - restarts, event messages 519
 - sample configurations ??—109, 155—171
 - test log 499, 514, 520
- system admin, basic programming 281
- system configuration checklist 179
- system coordinator
 - changing the password 386
 - common changes 307
 - extra programming 306
 - passwords 277
 - programming 281
 - programming overlay 306
 - system programming 306
- system coordinator plus
 - interface headings 280
 - password description 278
 - programming the password 386
- system features, telco features, programming 352
- system ID
 - access 453
 - finding 293
 - software keys 453
- system initialization self-test 275
- system modules, view 455
- system overview 188
- system power, clock source loops 478
- system prgrming
 - access codes 416
 - alarmset 406
 - answer key 408
 - auto DN 420
 - autotime&Date 402
 - backgrnd music 397
 - call log space 405
 - camp timeout 398
 - CAP assignment 411
 - daylight time 402
 - delayed ring transfer to prime(DRT) 400
 - dialing plan 412
 - direct-dial 410
 - directed pickup 401
 - DN length 427
 - DRT delay 400
 - featr settings 397
 - held reminder 400
 - hospitality services 439
 - message reply enh 407
 - on hold 398
 - page timeout 402
 - page tone 401
 - park mode 399
 - park timeout 399
 - programming CbC limits 437
 - receiver volume 398
 - release reasons 438
 - remind delay 401
 - remote access 423
 - set relocation 407
 - telco features 447
 - top level 304
 - transfer call back 399
 - user interface 280
- system prgrmg
 - BusName 429
 - programming CbC services 435
- system profile
 - choosing 296
- system profile startup 296
- System programming
 - ETSI programming 166, 170, 445
- system programming
 - hunt groups 391
 - see also system prgrming
 - setting SWCA controls 403

- SWCA keys 403
- system settings
 - Answer key 408
 - Automatic Time and Date 402
 - Direct dial extension 409
 - host delay 406
 - link time 406
- system speed dial 381
- system startup
 - timing for programming 301
 - warm start 275
- System version 485
- system version
 - finding 487
 - listing 280
- system-wide call appearances, see SWCA

T

- T loop, power 269
- T network, wiring 252
- T reference point 51
- T/NT loops
 - BRI lines 471
- T1
 - adding digital trunks 199
 - answer mode 341
 - carrier failure standard 460
 - connecting to service provider 254
 - disconnect supervision 72
 - disconnect timer on card 460
 - ground start trunk mode 72
 - internal CSU
 - invalid mixed trunk configurations 483
 - invalid trunk configurations 482
 - line coding 464
 - line setting 337
 - profile support 297, 298
 - setting clock source 482
 - setting up CbC 105
 - signal diagnostics 533
 - through-fed repeaters 237
 - transmission performance 533
 - trunk data settings 334
 - valid mixed trunk configurations 483
 - valid trunk configurations 482

- T7100 telephone
 - accessing external lines 419
- T7316
 - programming overlay 283
 - programming telephone 282
- talk-back paging, external line port 273
- tandem network
 - call routing 119
 - shared line pools 102
- target line DN
 - DID trunk 83
 - PRI trunk 83
- target line number 74
- target line receive digit length 64
- target lines
 - assigning to set 309
 - default DID numbering 310
 - DID 71, 73
 - DID template 80
 - DID trunk 74
 - E&M network 97
 - if busy 339
 - incoming calls 80
 - incoming only 71
 - line pool 338
 - loop start and E&M 80
 - multiple, broadcast ring 309
 - no prime line 313
 - numbering 71, 80
 - received number 339
 - received number length 426
 - simultaneous calls 310
 - trunk data settings 334
- TE, see ISDN terminal equipment
- TEI
 - BRI card 474
 - default range
 - D-packet service
- Tel #
 - voice message center 447
- telco features
 - copy 330
 - lines 280
 - programming 447
 - programming for lines and sets 330
 - programming system features 352
 - terminals&sets 280
 - top level 304
 - voice message routing 447

- telecommuting using ISDN applications 174
- telephone
 - copy programming 290—293
 - emergency 265
 - emergency, single-line 265
 - Feature button 282
 - handsfree button 282
 - Hold button 282
 - installing Norstar sets 265
 - loop specifications 589
 - Release button 282
 - troubleshooting 549—552
 - voice message waiting indication 331
 - volume control 282
- telephone loud ring amplifier 181
- telephones
 - answer keys 408
 - assign prime set 340
 - basic password 278
 - button icons 282
 - call blocking (\square 819) 432
 - CAP assignments 411
 - changing numbers 397
 - control sets 354
 - directed pickup 401
 - DRT on prime sets 400
 - equipment list 179
 - external access code 419
 - maintaining programming 267
 - manual-answer E&M trunks 78
 - maximum line buttons 311
 - message reply enh, programming 407
 - moving 267
 - moving tips 267
 - page timeout 401, 402
 - prime line 313
 - programming 282
 - programming an alarm set 406
 - programming call log space 405
 - programming direct dial 410
 - programming display buttons
 - programming feature settings 397
 - programming overlays 283
 - programming, system coordinator password 278
 - programming, viewing the settings 294
 - relocation 407
 - selecting lines for direct dial 410
 - set name 320
 - set relocation 267
 - set restrictions 327
 - user restrictions 86
- telephones, programming a direct-dial number 419
- temperature ICS 182
- template
 - changing default 302
 - remote access package defaults 424
 - Startup 279
- terminal endpoint identifier, see TEI
- terminal endpoint identifiers, see TEI
- terminal equipment
 - S or T wiring 268
 - U-LT jack pinout 270
 - U-LT wiring 270
- terminal resistors 268
- Terminals&Sets 308—332
 - capabilities 317
 - allow redirect 318
 - ATA settings 318
 - auxiliary ringer 318
 - d-dial 317
 - DND on busy 317
 - fwd no answer 317
 - fwd on busy 317
 - handsfree 317
 - HF answerback 317
 - hotline 318
 - page zone 317
 - paging 317
 - pickup grp 317
 - priority call 317
 - redirect ring 318
 - line access 308
 - answer DN 314
 - intercom keys 314
 - line assignment 309
 - line pool access 312
 - OLI# 315
 - prime line 313
 - name 320
 - restriction filters 350

- restrictions 322
 - user preferences 321
 - voice messages 448
- terminals&sets 304
- terminating resistors, see termination for ISDN loop
- termination for ISDN loop
 - description 222
 - shorting straps 223
- testing
 - ISDN network connection 211
 - loopback tests 525
 - system test log 499
- Tests 485
- third party software, DNIS number 346
- third-wire ground 184
- through-fed repeaters, disable internal CSU 237
- TI
 - CO fail 460
 - connecting wiring 239
 - framing 462
 - ISD/TT 461
- TIA-547A
 - carrier failure standard 460
- Tie
 - calling from within the network 159
 - calling other nodes within the network 160
 - CbC service 433
 - dialing plan 106
 - incoming calls 106
 - PRI lines 105
 - public call to private network 156
 - routing 362
 - routing table 365
- time display, hospitality 440
- time format, hospitality 441
- time switches
- time&date 304, 388
- time, see AutoTime&Date
- timeout
 - paging 402
- timer
 - answer 460
 - disconnect, on card 460
- times, service 440
- timing master, clock source 477
- timing reference, ClockSrc 464
- T-loop, terminating resistors 222
- toll calls over a private network 124
- tones
 - hospitality 441
 - on hold 398
 - ONN blocking 432
 - paging 401
 - programming analog VSC 449
- tools
 - programming 282
- TR64211, carrier failure standard 460
- transaction terminals 68
- transfer callback 399
- transmit
 - objective loudness 461
 - setting gain 347
- transparent dialing plan, see also CDP trnsfr callbk 399
- TRO
 - SL-1 network
- troubleshooting 545
 - alarms 510
 - ATA 562
 - auxiliary ringer 563
 - background music 564
 - DTI 567
 - emergency telephone 552
 - external paging 564
 - general procedure 548
 - line pools 585
 - lines 553—561
 - modules 566—569
 - network or remote users 576—588
 - optional equipment 562—564
 - replacing a telephone 551
 - T1 signal 569
 - telephones 550—552
 - trunk cartridge 566
 - trunk module 574
 - types of problems 547
 - voltages on E&M leads 581
- trunk
 - BRI 79
 - cartridge
 - checking the state 497
 - number attached to a module 496
 - troubleshooting 566
 - changing trunk type 335

- common data 335
 - dial mode 338
 - DID 73
 - DID, restrictions 74
 - disable cartridge 336
 - DTI 71
 - E&M 71, 75
 - ground start 72
 - loop start 71, 75
 - module troubleshooting 574
 - numbering 71
 - PRI 71, 79
 - prime set, overflow 340
 - programming received number 339
 - programming trunk mode 341
 - programming type 335
 - super, ans mode 341
 - tandeming, calling name information 430
 - types 71
 - trunk answer, programming 358
 - trunk antitromboning (TAT), MCDN 45, 111, 140
 - trunk cards
 - profile 1 297
 - profile 2 297
 - profile 3 298
 - profile 4 298
 - trunk cartridge
 - E&M wiring chart 257
 - enable/disable for programming 464
 - installation planning 185
 - installing 221
 - line capacity 185
 - mixing in a Trunk module 185
 - port numbers 241
 - programming, disable/enable 336
 - trunk module, E&M/DISA 258
 - types 214
 - trunk mode
 - data settings 334
 - programming 341
 - trunk module
 - BRI-ST cartridge wiring 262
 - connecting 224
 - description 467
 - DID trunk cartridges and RJ-21 wiring connections 259
 - E&M network 97
 - emergency telephone installation 265
 - line number 205
 - power 275
 - trunk route optimization (TRO), MCDN 138
 - trunk route optimization, see TRO
 - trunk type 334
 - trunk/line data
 - copying 335
 - user interface 280
 - trunks
 - assigning physical trunks 309
 - CLASS 402
 - MICS-XC loop start compatibility 77
 - operating modes 72
 - programming analog VSC 449
 - programming if busy 339
 - set appearances 72
 - trunk type data settings 334
 - twelve-port Expansion Cartridge 229
 - twinning, hunt group 390
 - two-port expansion cartridge 227
 - type, BRI card loops 471
- U**
-
- U interface 49
 - U-2 line numbers 468
 - U-4 line numbers 468
 - UDP
 - call routing 128
 - call scenarios 127
 - dialing plan features 412
 - location code 95
 - overview 94
 - private access codes 95
 - private DN length 95
 - SL-1 network features
 - U-LT
 - jack and plug pins 270
 - reference point 49
 - wiring chart 270
 - unassigned 147, 152, 309, 315
 - UNEQUIPPED 492, 497
 - uninterruptible power supply (UPS) 181
 - universal dialing plan, see UDP
 - unknown name 429

unknwn number 332
 unsupervised, programming trunk mode 341
 U-NT
 network wiring 252
 reference point 50
 updates
 viewing programming 287
 Updating state 497
 upgrade tool 193
 upgrading 193
 0X32 release 1-T1 195
 8X24 201
 call log information lost 196
 from ILG to Hunt Groups 206
 MICS to MICS-XC 196
 Modular 8X24 Key Service Unit (KSU) 195
 software upgrade before hardware upgrade 189
 supported upgrades 192
 U.S. MICS-XC systems lose UTAM information 196
 upgrading system 189—205
 US regulations 23
 Usage metrics
 call by call 542
 Hunt groups 541
 usage metrics
 top level 305
 user interface 280
 use pool 364
 use set volume 398
 use sys volume 398
 user call restrictions 349
 user filter, line/set restriction 383
 user preferences
 listing 280
 programming 289, 321
 user restrictions 349
 set 86
 user speed dial
 user preferences 289
 user prefernces 321

V

vacancy, room 440
 ventilation

ICS 182
 version number, check device 491
 vertical service code, see VSC
 videoconferencing and video using ISDN applications 173
 videophones, hunt groups 390
 view 286
 view prefix 415
 viewing
 assigned lines 311
 long telephone numbers 288
 programming for a telephone 294
 programming updates 287
 VMsg center 352
 VMsg ctr Tel#s 447
 VMsg ctr tel#s 280
 voice mail
 external access 331
 on SL-1 network 111
 voice message
 accessing 331
 external center 447
 programming 352
 telephone setting 448
 waiting indication 331
 voice path 289
 voice, call type 473
 volume, system or set 398
 VSC
 ONN SrvcCode 450
 programming for BRI 449
 setting up the modules 450
 VSC, analog vertical service code for ONN blocking 449

W

wait for dial tone, dialout 364
 wakeup 207
 warm start 275
 wild card
 destination codes 368
 dialing restrictions 325
 wild cards
 destination code 369
 WinkStart signal type 345
 wireless
 hunt group twinning 390
 wiring

- auxiliary ringer 271
- BRI-ST 249
- BRI-U 250
- connecting 237
- cross-connect 237
- ICS 248—254
- ISDN S loop 187
- loopback test 525
- modules 240
- requirements 186

wiring chart

- auxiliary equipment 245
- BRI 248—251
- BRI trunk module 262—264
- BRI-ST cartridge 262
- BRI-ST wiring 249
- DID trunk cartridge 259
- DTI 254
- E&M trunk cartridge 257
- E&M/DISA trunk cartridge 257
- ICS external loop start lines 247
- ICS telephone 244, 245
- loop start or CI trunk 256
- port numbering 241
- S or T extension wiring 268
- S or T terminal equipment 268
- station module 255
- T network connection 252
- trunk module with DID trunk
cartridge 260
- trunk modules with E&M/DISA 258
- U-LT terminal equipment 270
- U-NT network 252

X

X.25, converting ISDN protocol 68

Z

Z, dialpad 278, 300
zero absorb length 374

Backup programming overlays

